

**IBM Z Software Asset Management Version  
8.3 Administration Guide and Reference**

# Contents

<b>Chapter 1. Product overview</b> .....	<b>5</b>
Implementing IBM Z Software Asset Management with SQLite database.....	8
Accessibility.....	8
How to read the syntax diagrams.....	9
What's changed/added in New in IBM Z Software Asset Management Version 8.2 1.1 after Oct 2019.....	12
<b>Chapter 2. Planning for deployment</b> .....	<b>17</b>
Predeployment considerations.....	17
Deployment data processes.....	17
Deployment for a single Repository.....	18
Deployment for multiple Repositories.....	19
<b>Chapter 3. Installing and customizing IBM Z Software Asset Management</b> .....	<b>21</b>
Installation prerequisites.....	21
System configuration requirements.....	22
Security and authorization requirements.....	22
Checklist of installation and customization tasks.....	24
Installing target libraries.....	27
Preparing Db2® database prerequisites.....	28
Preparing local environment settings.....	28
Configuring a test Repository database.....	33
Configuring a production Repository database.....	36
<b>Chapter 4. Implementing deployment scenarios</b> .....	<b>40</b>
Scenario 1: Implementing a single Repository database with a single GKB database.....	40
Scenario 2: Implementing multiple Repositories with a shared GKB database.....	41
Scenario 3: Implementing multiple Repositories with multiple GKB databases.....	42
Scenario 4: Collecting and transferring Inquisitor and usage data from remote sites.....	44
Scenario 5: Implementing in a sysplex environment.....	44
<b>Chapter 5. Migrating to IBM Z Software Asset Management Version 8.2 1.1</b> .....	<b>47</b>
Migrating to IBM Z Software Asset Management from an earlier version.....	47
Migrating from version 8.1 to Version 8.2 1.1 (Db2® database).....	47
Migrating from version 8.1 to Version 8.2 1.1 (SQLite database).....	54
Post migration errors.....	57
Migrating repositories between different databases (optional).....	59
<b>Chapter 6. Collecting and importing data with IBM Z Software Asset Management</b> .....	<b>61</b>
Updating the Global Knowledge Base.....	61
Collecting scanned libraries with the Inquisitor for z/OS.....	61
Running the Inquisitor program.....	62
PLX parameter of the Inquisitor program.....	62
Inquisitor program parameters and files.....	63
Inquisitor program command syntax.....	65
Inquisitor examples.....	72
Designing Inquisitor requests.....	75
Controlling the data extraction level.....	76
Extracting LE compile unit information.....	76
Scanning migrated libraries.....	77
Scanning generation data sets.....	78
Logical Volume Mapping.....	78
Collecting information about the I/O configuration.....	83
Collecting UNIX files with the Inquisitor for z/OS UNIX.....	83
Inquisitor for z/OS® UNIX® overview.....	83
Running the Inquisitor for z/OS® UNIX® program.....	84
PLX parameter of the z/OS® UNIX® Inquisitor program.....	84
Inquisitor for z/OS® UNIX® program parameters and files.....	85
z/OS® UNIX® Inquisitor example.....	87
Security considerations.....	87
Collecting usage data with the Usage Monitor.....	88
Setting up the Usage Monitor.....	88
Starting and stopping the Usage Monitor.....	93
Refresh processing for the Usage Monitor.....	93
Usage Monitor commands.....	94
Monitoring usage in CICS® regions.....	118
Customizing a CICS region to provide usage data.....	119
Importing Inquisitor data.....	120
Running the Inquisitor Import.....	120
Import filters and matching.....	121
TPARAM parameters.....	121

Importing usage data.....	123	Dynamic invocation by other programs.....	181
TPARAM parameters.....	123	HSZIP data set support.....	181
Aggregating usage and discovery data.....	124	HSZIP return codes.....	182
TPARAM parameters.....	124	Browsing zipped data.....	182
Activating the Automation Server.....	125	Browsing active collection data.....	184
Automation Server overview.....	125	Verifying database changes since the product was released.....	184
Running the Automation Server.....	127	<b>Chapter 9. Configuring language support.....</b>	<b>185</b>
Automation Server control data set maintenance.....	134	Configuring Japanese messages.....	185
<b>Chapter 7. Reporting with the Analyzer.....</b>	<b>136</b>	Enabling the Analyzer utility for Japanese.....	185
Analyzer prerequisites.....	136	Configuring the Japanese Db2® subsystem for use with IBM Z Software Asset Management .....	186
Analyzer JCLLIB and PARMLIB members.....	137	Configuring the Turkish Db2 subsystem for use with IBM Z Software Asset Management.....	190
Running the Analyzer in online mode.....	138	<b>Chapter 10. Reference information for IBM Z Software Asset Management .....</b>	<b>192</b>
Analyzer communication port.....	140	Repository table layouts.....	192
Analyzer inactivity timeout.....	141	Post-installation jobs.....	221
Analyzer security.....	141	Jobs generated in JCLLIB for a Db2® environment.....	221
Analyzer BASIC security.....	141	Jobs generated in JCLLIB for a remote environment.....	225
Analyzer SYSTEM security.....	144	Jobs generated in JCLLIB for an SQLite environment.....	226
SSL Certificates.....	147	Database performance and tuning.....	230
Online login to the Analyzer.....	153	Db2® database.....	230
Controlling the Analyzer address space.....	156	SQLite database.....	232
Running the Analyzer in batch mode.....	156	Database resources used by IBM Z Software Asset Management.....	232
<b>Chapter 8. Running utilities.....</b>	<b>160</b>	<b>Chapter 11. Troubleshooting and support.....</b>	<b>238</b>
Condensing usage data with the ZCAT utility.....	160	Troubleshooting a problem.....	238
Deleting usage data with the Usage Deletion utility.....	164	Problems and solutions.....	239
Deleting a specific system with the System Deletion utility.....	165	<b>Chapter 12. IBM Z Software Asset Management messages.....</b>	<b>245</b>
Deleting obsolete data with the Physical Deletion utility.....	166	HSIA - Automation Server messages.....	245
Deleting obsolete audit records with the MDEL Deletion utility.....	167	HSIC - Operation messages.....	251
High-level qualifier listing.....	168	Error codes.....	264
Updating the TPARAM table.....	169	HSII - REXX utility messages.....	279
Tagging unidentified products with the Product Tagging utility.....	169	HSIP - Inquisitor for z/OS® messages and codes... ..	293
Product tagging process.....	169	HSIT - Product tagging messages.....	329
Product tagging job and control statements.....	170	HSIX - Inquisitor for z/OS® UNIX™ messages and codes.....	340
Product tagging examples.....	172	HSIZ - Usage Monitor messages.....	344
Importing subcapacity reporting data with the SCRT Import utility.....	173	Appendix. Description of output message content.....	ccclxxxix
Extracting data with the XML Export utility.....	174	Notices.....	ccclxxxvii
Transferring output XML by FTP.....	175		
Loading data into a staging table (for Db2® only).....	175		
Compressing and decompressing data sets with the HSZIP utility.....	176		
Text data processing.....	176		
Binary data processing.....	177		
HSZIP program parameters.....	178		
HSZIP files.....	181		

**Index.....390**

# Chapter 1. Overview of IBM Z Software Asset Management

IBM Z Software Asset Management is built on the concept of remote and central mainframe components which work together to produce reports on z/OS® mainframe products and their usage. This section provides you with a high-level overview of the IBM Z Software Asset Management core architecture.

IBM Z Software Asset Management runs on z/Architecture® mainframes that use the z/OS® operating system. Its purpose is to:

- Discover and identify products for the z/OS® platform.
- Monitor software usage and trends.
- Report on the MSU capacity of each system under which the product runs.
- Provide reporting functions for assets and usage.

The benefits of using this software are:

- Used and unused software are identified.
- Users of software are identified.
- Obsolete versions of software are identified and the usage of these versions determined.
- Usage trends of software and libraries are identified.

In a z/OS® environment, software is contained in load libraries or as z/OS® UNIX™ executable files. IBM Z Software Asset Management scans contents of these libraries and executable files to determine which software products are installed. IBM Z Software Asset Management also monitors the loaded programs and executable files to measure software usage.

The discovered load libraries and executable files are then checked against a global database of product information. IBM Z Software Asset Management uses this information to determine which products are installed and used on each system.

The IBM Z Software Asset Management Usage Monitor gathers information about events for modules and executable files which are then attributed to each product.

The workflow is illustrated in [Figure 1: Product workflow on page 6](#), followed by a brief description of the components.

Figure 1. Product workflow

**Remote Mainframe Components**

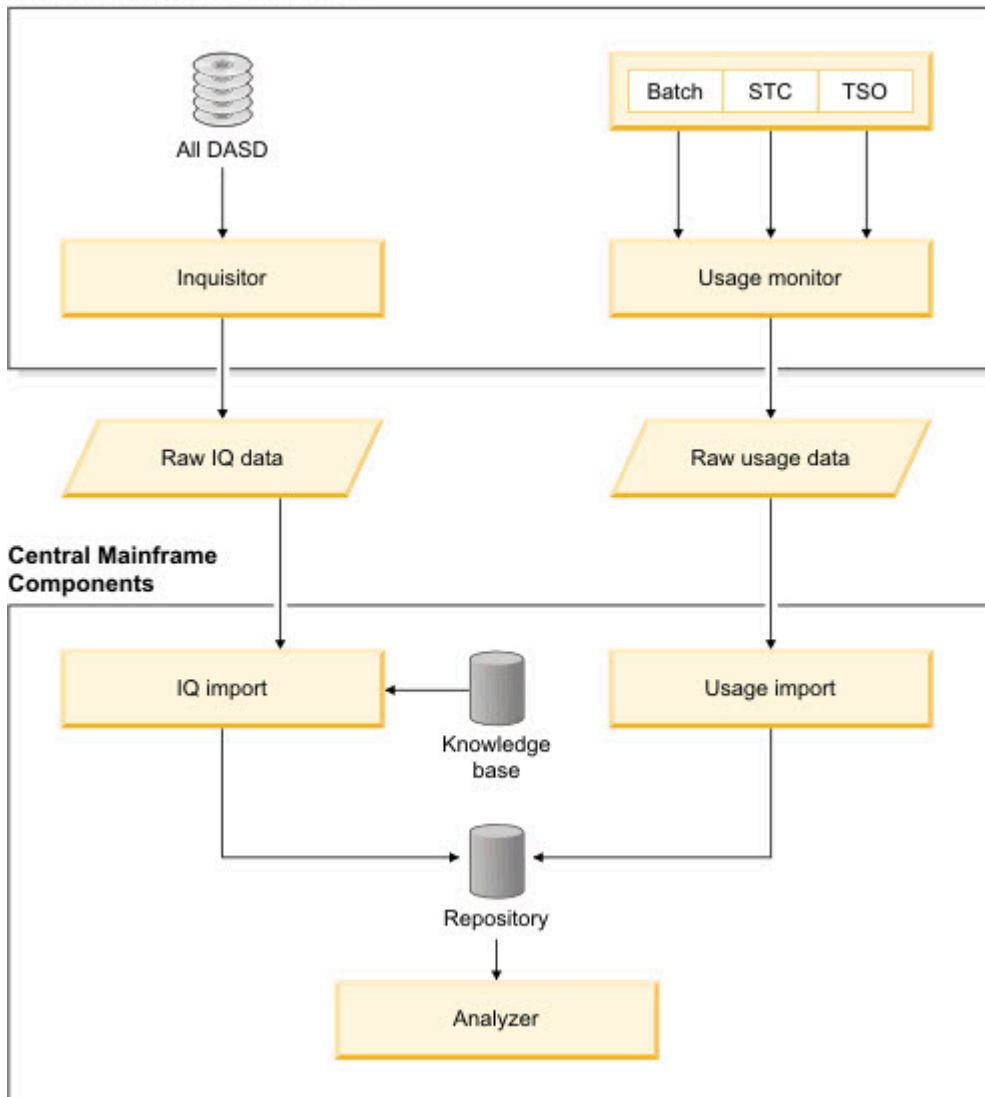

**Inquisitor**

The Inquisitor is a batch job that discovers loadable programs in z/OS® data sets and z/OS® UNIX™ System Services file systems. A program locates load libraries on z/OS® DASD devices and captures information about the load modules. The process can be targeted to specific devices, libraries, or groups of libraries. The program creates a compressed data set, which is then used as input to the Inquisitor Import procedure.

An additional process locates and scans z/OS® UNIX™ directories for program objects and captures this information. The process creates a compressed data set that is then used as input to the Inquisitor Import for z/OS® UNIX™ procedure.

**Usage Monitor**

The Usage Monitor is a started task or batch job that monitors and records loaded modules of batch jobs, started tasks, TSO users, and z/OS® UNIX™ executable files.

**Knowledge Base**

The Global Knowledge Base (GKB) is a database that is provided with IBM Z Software Asset Management . The GKB has a list of all z/OS® globally-identified products that are used by the product in the process of matching.

**Inquisitor (IQ) Import**

The Inquisitor Import is a batch job that loads Inquisitor data into database tables on z/OS® for z/OS® load modules and z/OS® UNIX™ program objects. The imported Inquisitor data is then matched against the Global Knowledge Base.

**Usage Import**

The Usage Import is a batch job that imports Usage Monitor data into the Repository. The data is matched against load modules and z/OS® UNIX™ executable files and the data is then aggregated with installed software products. After this process has been completed, you can view the usage data with the IBM Z Software Asset Management Analyzer reports.

**Repository**

The Repository is a set of database tables for z/OS® data that stores information about the software products discovered and their usage data.

**Analyzer**

The Analyzer queries the IBM Z Software Asset Management database and displays Analyzer online reports. The Analyzer runs as a started task or batch job on the same z/OS® system where the Db2® subsystem or SQLite database runs. The output formats can be XML, HTML, Excel, text, or comma separated value (CSV). You can logon to the Analyzer from a web browser to display interactive reports. You can also run the Analyzer in batch mode and save the results to an output data set on z/OS®.

**Process flow**

Data collected on the target systems by the Inquisitor and the Usage Monitor batch programs, are then imported into the Repository database tables. The database is located on a z/OS® system within a Db2® subsystem or a SQLite database.

Following is a summary of the workflow tasks:

1. Importing and matching the data collected by the Inquisitor.
2. Importing the collected usage data into the Repository.
3. Running utilities to manage and maintain your data. This task is optional.
4. Reporting using the Analyzer, which consists of online and batch components.

## Implementing IBM Z Software Asset Management with SQLite database

You can implement IBM Z Software Asset Management with an SQLite database if you do not have a Db2® for z/OS® license, or if you are currently unable to deploy one. If you implement IBM Z Software Asset Management with an SQLite database, there are certain functional and performance limitations.

SQLite is an in-process library that implements a self-contained, serverless, transactional SQL database engine. It is an embedded SQL database engine that is unlike many other SQL databases, because it does not have a separate server process. SQLite reads and writes data directly to ordinary disk files. When you implement SQLite with IBM Z Software Asset Management, the complete SQL database is contained within a single z/OS® UNIX® zFS file.

### Limitations

IBM Z Software Asset Management with SQLite database is implemented with the following configuration:

- 500 products identified from 15 LPARs
- 3 months usage data (about 6 million usage records)
- Only 1 repository within a zFS file

This configuration represents the limitation for SQLite support with IBM Z Software Asset Management. Only one repository within a zFS file is supported. If you require a database with a larger configuration supporting multiple repositories, consider implementing IBM Z Software Asset Management with Db2® for z/OS®.

SQLite has limited concurrency because it uses read/write locks on the entire database file. Therefore, if any process is reading from any part of the database, all other processes are prevented from writing to any other part of the database. Similarly, if any one process is writing to the database, all other processes are prevented from reading any other part of the database.

## Accessibility

Accessibility features help a user who has a physical disability, such as restricted mobility or limited vision, to use software products successfully.

### System console

You can set up, run, and maintain IBM Z Software Asset Management using a 3270 emulator as the system console. IBM Personal Communications provides 3270 emulation with accessibility features for people with disabilities.

### Reporting

The online version of the Analyzer reporting utility provided by IBM Z Software Asset Management supports the standard keyboard commands that are used by screen reader applications. You can generate reports in a variety of accessible formats, including HTML and Excel file formats.

### Images

All images in the information center that convey additional information have alternate text.

## Tables

You can navigate the content of all tables in the information center with a screen reader application.

## Syntax diagrams

Syntax diagrams in the information center are displayed as railroad track images. Each syntax diagram has a link to a dotted decimal version of the diagram that can be read by a screen reader application.

## IBM and accessibility

For more information about the commitment that IBM has to accessibility, see the IBM Human Ability and Accessibility Center. The IBM Human Ability and Accessibility Center is at the following web address:

 <http://www.ibm.com/able> (opens in a new browser window or tab)

## How to read the syntax diagrams

The syntactical structure of commands that are described in this document is shown by means of syntax diagrams.

[Figure 2: Sample syntax diagram on page 10](#) shows a sample syntax diagram that includes the various notations that are used to indicate such things as whether:

- An item is a keyword or a variable.
- An item is required or optional.
- A choice is available.
- A default applies if you do not specify a value.
- You can repeat an item.

Figure 2. Sample syntax diagram

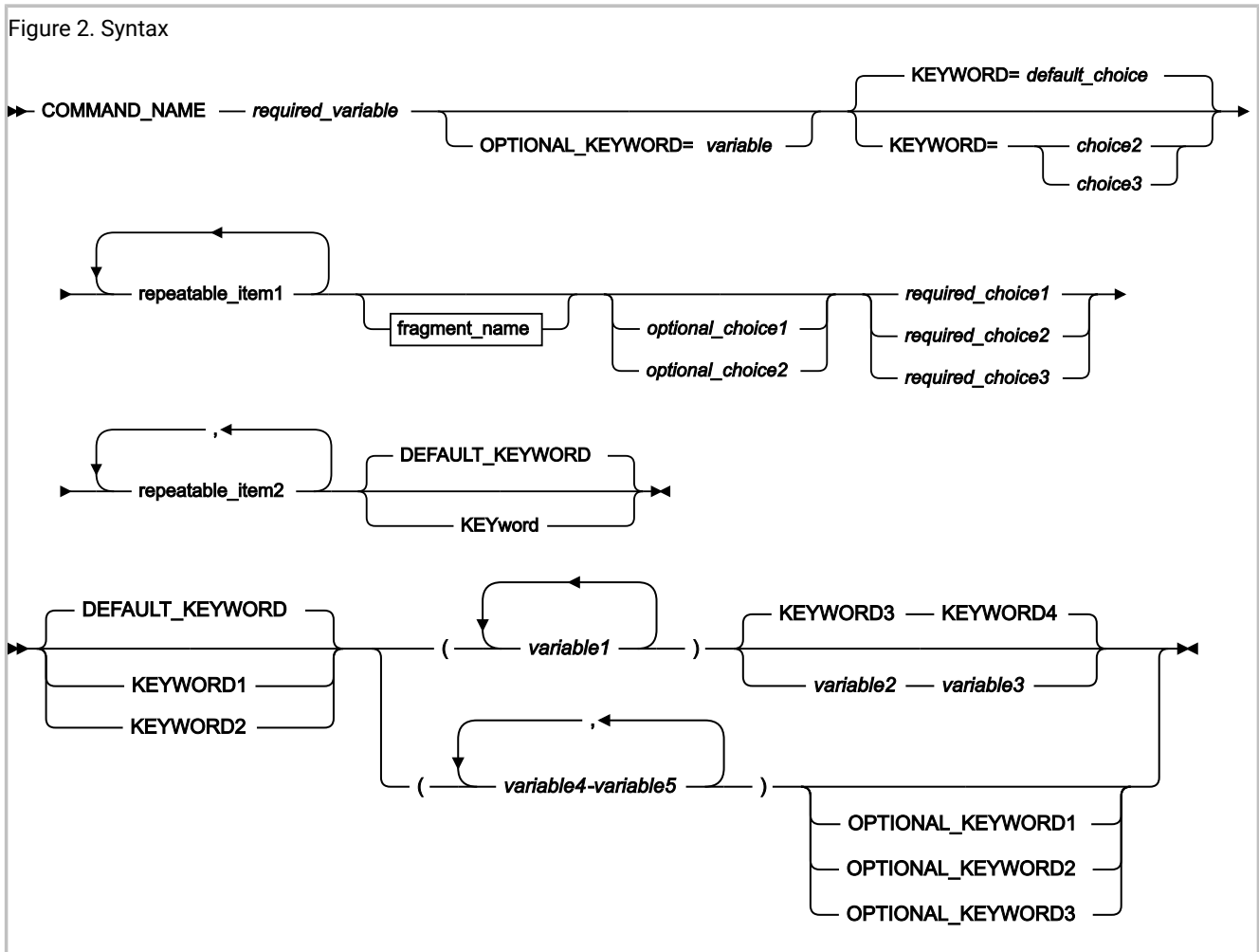

Here are some tips for reading and understanding syntax diagrams:

**Order of reading**

Read the syntax diagrams from left to right, from top to bottom, following the path of the line.

The ▶▶— symbol indicates the beginning of a statement.

The —▶ symbol indicates that a statement is continued on the next line.

The ▶— symbol indicates that a statement is continued from the previous line.

The —▶◀ symbol indicates the end of a statement.

**Keywords**

Keywords appear in uppercase letters.

▶▶ COMMAND\_NAME ▶▶

Sometimes you only need to type part of a keyword. The required part of the keyword appears in uppercase letters.

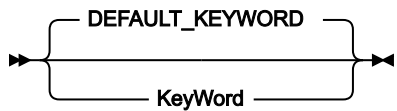

In this example, you could type "KW" or "KEYWORD".

The abbreviated or whole keyword you enter must be spelled exactly as shown.

### Variables

Variables appear in lowercase letters. They represent user-supplied names or values.

▶▶ *required\_variable* ◀◀

### Required items

Required items appear on the horizontal line (the main path).

▶▶ COMMAND\_NAME — *required\_variable* ◀◀

### Optional items

Optional items appear below the main path.



### Choice of items

If you can choose from two or more items, they appear vertically, in a stack.

If you *must* choose one of the items, one item of the stack appears on the main path.

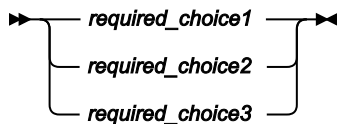

If choosing one of the items is optional, the entire stack appears below the main path.

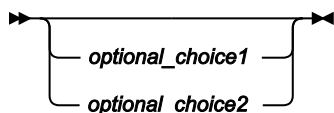

If a default value applies when you do not choose any of the items, the default value appears above the main path.

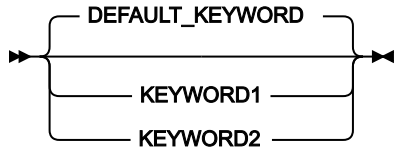

**Repeatable items**

An arrow returning to the left above the main line indicates an item that can be repeated.

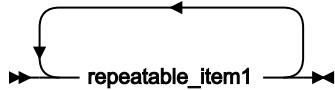

If you need to specify a separator character (such as a comma) between repeatable items, the line with the arrow returning to the left shows the separator character you must specify.

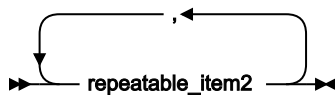

**Fragments**

Where it makes the syntax diagram easier to read, a section or *fragment* of the syntax is sometimes shown separately.

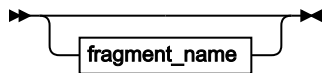

⋮

fragment\_name

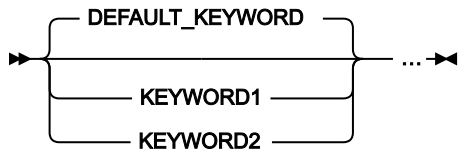

## What's changed/added in New in IBM Z Software Asset Management Version 8.2 1.1 after Oct 2019

New features and capabilities in IBM Z Software Asset Management version 8.2 1.1 help your organization achieve greater efficiency in asset discovery.

The following items/sections have been changed or added to the IBM Z Software Asset Management Version 8.2 1.1 Administration Guide and Reference manual:

- Added new section [Configuring the Turkish Db2 subsystem for use with IBM Z Software Asset Management on page 190](#).
- Usage Monitor updates, including CICS LPA usage detection and PLPA index build loop after previous abend ; new command added [TMP - Set temporary data set collection status on page 113](#);
- New message HZAZ088I added ([IBM Z Software Asset Management messages on page 245](#)) (OA60143)
- Updated [ZCAT001 on page 163](#) to provide either zipped or unzipped input data (OA60955)(OA60935)
- New error code added for SCRT Import - 6062 8280.
- Aggregator usage reports now contain usage for products that are disabled in IFAPRDxx
- Change to HSISCUST - BP range check
- Resolved IQ Import -803 abend
- Fixes applied to the following reporting issues in the Analyzer:
  - When processing LPAR names with # symbol
  - Discovered use by month extra column on right side
  - Audit report showing incorrect results
  - Audit report does not take into account date selections correctly
  - Added multirep support to more reports. Some other reports fixed as well
  - Audit report not parsing to date correctly

### Support for Product Suites

Product Suite support has been added to IBM Z Software Asset Manager. This release removes the previous support for Product Suites where users have to manually create their own Product Suites via the Admin report 'Define Product Suites'. Support for IBM and ISV products has been added.

### Support for SCRT Tailored Fit Pricing

SCRT Tailored Fit Pricing has been added to IBM Z Software Asset Manager. The current SCRT Import program now supports SCRT Tailored Fit Pricing. A new report has also been added for users to view their Tailored Fit Pricing data.

### Changes in Analyzer reports

IBM Z Software Asset Manager provides new reports and adds additional information to existing reports:

- New Asset report 'SCRT Tailored Fit Pricing' (TFP) has been added. Users can view their SCRT data as TFP if they are now using this facility.
- New Asset report 'Product Suites' shows which suites have been identified and the products that belong to the suites.
- Admin report 'Define Product Suites' is removed.
- New Admin report 'Exclude Product Suites' enables users to decide whether to exclude Products Suites from the report if suites have been identified incorrectly, when only some of the products have been installed. If suites are not defined in the GKB, users need to open a Case with IBM to have the suites added.
- New Admin report 'Define VUE Products' enables users to create a list of MLC products that are now VUE. This list will then be used to update the repository Asset reports with the VUE information. The list needs to be created once only or when a previous product that was MLC is now VUE.

- New Admin reports – ‘Define Library Classifications’ and ‘Assign Library Classifications’ have been added to support Product Lifecycle data. This enables users to create Library Classifications for products that move between different libraries, as the life of a product changes.
- Discovery report ‘Product Libraries’ has been enhanced for users to select and view these library classifications.
- New Charting tool has been added to the Trend Report. This improves chart creation performance considerably.
- Analyzer batch reports can now have user defined headings.

### **Changes to the Inquisitor**

The Inquisitor new program parameter settings:

- NOVSR – suppress the volume statistics report
- NOEAR – suppress the execution activity report
- NOREP – specify both NOVSR and NOEAR with one keyword

### **Support for Deflate has been added**

The default zip file compression algorithm has been changed from shrink to fast deflate which produces greater compression with minimal additional CPU consumption.

### **Recover from S213-C8 abends**

Data collectors which write zip files will recover from S213-C8 abends by writing unzipped data, thereby reducing operational disruption.

### **Changes to the Inquisitor Import**

During Inquisitor import, support to identify Product Suites has been added. This allows users to view Suite information in the Asset report ‘Product Inventory’, without seeing all products associated with the Product Suite. A new Asset report ‘Product Suites’, has been created for viewing suites and their associated products.

### **Changes to the Usage Monitor**

Product Use information that are collected allows users to see actual product use data.

The following new commands have been added to the Usage Monitor:

- APF – control the collection of APF library names
- ASZ – specify the size of the ASID array
- D-L – display long running program names
- DCL – specify SMS data class
- IMS – control the collection of IMS-managed program usage
- LDD – new name for LDI (delete LDX entry)
- LPR – specify additional long running program names
- MCL – specify SMS management class
- LPD – delete entries created by LPR

- PAK – control output zip algorithm
- SCL – specify SMS storage class
- TMP – control collection from temporary program library data sets

Improvements in Usage Monitor data collection facilitate the following changes:

- System SVC front ends are no longer installed.
- A user ESR will be used for CICS and UNIX data collection.
- Usage of IMS-managed programs is now accurately reported.
- A count for the number of jobs which use each program each day is kept.
- The LLC (linklist correction) setting is now retired.
- CPU time can now be monitored down to the RB level.
- CPU time consumed by long running address spaces can now be reported progressively each collection cycle.

### Changes to the Usage Import

Usage Import now imports usage data to create new Metric Product Use. This new Metric displays actual product Usage as well as the current Module Event data, so as to give a better view of product usage. This provides information to users who are interested in the number of times products are used.

### CICS Transaction Server monitoring

Installed GLUE modules from older releases of the Usage Monitor will not collect any data for this release of the Usage Monitor. The GLUE modules in this release of the Usage Monitor cannot collect any data for older releases of the Usage Monitor.

The following table lists the required GLUE programs for different versions of the CICS Transaction Server currently supported by IZSAM.

CICS Transaction Server release	Usage Monitor GLUE modules
Version 5, releases 1, 2, and 3	HSIZFTC3, HSIZEI13
Version 5, releases 4, 5 and 6	HSIZFTC4, HSIZEI14

### Changes to the GKB

The GKB now supports Product suites. This new enhancement groups individual products together into a single product name, and this can then be reported in the Asset report 'Product Inventory'.

Support for VUE products has also been added to the GKB. Users will now be able to assign VUE product information to supported IBM products.

A version 8.1 repository can use only a version 8.1 GKB database. A version 8.2 repository can use only a version 8.2 GKB database.

### **Db2 Universal Table Spaces and Compression**

All Repository and GKB tablespaces are now defined as partition-by-growth universal tablespaces (UTS). The tablespaces and indexes are also defined with 'COMPRESS Y'. With UTS, Db2 space limitation is no longer an issue and with 'COMPRESS Y', there are significant savings in space utilization, especially for the largest tables - TUSEMTD and TMODULE.

### **Support for New SQLite database**

This release adds support for the latest level of SQLite database as an alternative to the Db2 database. This new database support provides improved performance.

### **Deprecated items**

HSISUSUM - Usage Summary utility is no longer required. Repository tables TUIMPORTCTRL and TUSELIB have been removed.

---

# Chapter 2. Planning for deployment

Before you deploy IBM Z Software Asset Management, consider which deployment option is best suited to your environment.

---

Related information

[Implementing deployment scenarios on page 40](#)

## Predeployment considerations

You can deploy IBM Z Software Asset Management to use a single Repository or multiple Repositories.

Implementing a deployment in a single Repository is relatively straightforward because the data from all systems is imported into a single Repository. Before you deploy with a single Repository, plan the following aspects of the deployment:

- How frequently will the Inquisitor scan each system?
- If you have systems that are located at remote sites, what mechanism will transfer collected Inquisitor and usage data through file transfer protocol (FTP) to the central site, and how frequently will these transfers occur?
- How often is it necessary to load Inquisitor and usage data from each system into the Repository?

To deploy with multiple Repositories, plan the following aspects of the deployment:

- How frequently will the Inquisitor scan each system?
- How many Repositories to include in the deployment and are all of these Repositories located at the central site?
- For each system, which Repository loads the Inquisitor and usage data for the system?
- If you have systems that are located at remote sites, what mechanism will transfer collected Inquisitor and usage data through file transfer protocol (FTP) to the central site, and how frequently will these transfers occur?
- How often is it necessary to load Inquisitor and usage data from each system into its specified Repository?

## Deployment data processes

IBM Z Software Asset Management is structured on several key data processes.

### **Inquisitor data**

The Inquisitor scans DASD volumes for libraries containing load modules and HFS/zFS files for z/OS® UNIX™ program objects and produces Inquisitor data. These load modules and program objects are matched and associated to a particular vendor and product and the matched information is then loaded into the Repository tables. These processes are performed by running the Inquisitor Import job.

## Usage event

A usage event describes a unique load of a load module or program object for an address space that can contain an account code. The Usage Monitor records these usage events as they occur on a particular operating system. After the usage data is imported into the Repository, each usage event is identified by the load module name, library name, and volume. It can then be associated to a particular product discovered on that system.

## Repository

The Repository is a collection of database tables that contain processed Inquisitor and Usage Monitor data. To ensure that accurate data is stored in the Repository tables, the following criteria must be met:

- The DASD VOLSERs of the data being imported must be unique unless the DASD VOLSERs are shared or are clones of each other with identical contents.
- The data imported must be from systems with unique SMF IDs.

When you are designing the scope of a Repository, there are a few common scenarios that most installations fit into. It is common to define the scope of a Repository based upon a data center. In this scenario, each data center in the organization has a separate Repository.



**CAUTION:** Import only DASD volumes with a unique VOLSER into your Repository.

The only way to prevent this sharing from taking place is to divide the z/OS® systems with conflicting DASD/SMF IDs into separate Repositories. This can entail running one Repository for each sysplex or stand-alone z/OS® system. With IBM Z Software Asset Management, it is common for IT service providers to define separate Repositories for each customer. This definition also satisfies the need for separation of data and ease of reporting.

It is recommended to have a central Db2® subsystem or SQLite databases that contain all the Repositories in your entire enterprise. The usage and Inquisitor data that require processing should be transmitted to this central Db2® subsystem or SQLite database by using the IBM Z Software Asset Management Automation Server or equivalent automation product.

## Deployment for a single Repository

The recommended procedure for deploying the Inquisitor and Usage Monitor to collect raw data is to deploy both components on every system in your organization.

After you deploy both components to each system in your organization, perform data collection in the following sequence:

1. Use the Inquisitor Job to scan all available DASD on each z/OS System.
2. Import Inquisitor data by running the Inquisitor Import job.
3. Ensure that the Usage Monitor is active on all z/OS® systems, directly after IPL.
4. Import Usage data by running the Usage Import job. Run this job after Inquisitor data has been imported.

IBM Z Software Asset Management displays products that have been discovered. Usage data collected from every system by the Usage Monitor is imported and usage events are assigned to the discovered products, enabling analysis of product use by system.

The first step in deploying IBM Z Software Asset Management is to run the SMP/E (System Modification Program/Extended) installation of the product, followed by the customization and creation of the database resources.

The next step is to create a test Repository. This deployment exercise is useful as it helps you to:

- Gain familiarity with the product.
- Check that your Repositories are defined correctly in terms of your business requirements and that the DASD VOLSERs and SMF IDs are unique.
- Ensure that data-sizing is adequate.
- Analyze the integrity of the data.

As part of this test implementation, you can then deploy the Inquisitor and Usage Monitor to all systems in your organization. It is advisable to first start the Usage Monitor on every system, in order to gather a significant amount of usage data. Place the test repository on a test or development Db2 subsystem.

At this point you can start the IBM Z Software Asset Management Analyzer and connect to the Repository. To verify the data collected by the Inquisitor and Usage Monitor, log on to the Analyzer and navigate to the Discovery menu tab. From this menu you can proceed to various reports on discovered products and module usage.

After you move your Repositories to their final location, you should consider setting up automation of the product.

## Deployment for multiple Repositories

Multiple Repositories can be required to provide support for more than one data center, for different geographical regions, and for running multiple customers.

Db2 only: It is recommended that not more than 50 repositories be defined in a Db2 subsystem that is referenced by each Analyzer. This is to prevent overload to the Analyzer and also for easier management of repositories.

You can locate multiple Repositories in one central location, or you can locate them in geographically dispersed locations. Multiple Repositories may be organized as follows:

1. For a central location
2. For geographically dispersed locations

### Central location

Each Repository contains data that is divided up into logical units, for example:

- Data center
- Outsourced customer
- Sysplex

Each Repository has its own database. For Db2®, all repositories must reside in the same Db2® subsystem. For SQLite, each repository must reside in its own SQLite database. For Db2® only, the advantage of this configuration is that reporting can be performed on data across all repositories. With this configuration, all repositories can share the same Global Knowledge Base (GKB) and you only have to maintain a single copy of the GKB.

### **Geographically dispersed locations**

Each Repository is defined with its own database at a specific geographic site as a stand alone operation. Reporting can only be performed for each specific Repository. The disadvantage with this configuration is that it can be necessary to consolidate Repository data to a central site for reporting purposes.

# Chapter 3. Installing and customizing IBM Z Software Asset Management

The product installation involves downloading the product and available updates, preparing the database, and configuring and populating a test database. After verifying that all components are correctly installed, you duplicate the test database to create a production database where you automate data collection and import tasks.

## Installation prerequisites

Before you install IBM Z Software Asset Management, verify that the required hardware and software are available in the installation environment.

### Hardware requirements

IBM Z Software Asset Management requires a z/Architecture® machine capable of running z/OS® Version 2 Release 4, or later.

### Software requirements

The software required for IBM Z Software Asset Management is:

- z/OS® Version 2 Release 4 or later with z/OS® UNIX® System Services configured.
- Database software: Either Db2® or SQLite. It is not necessary to install the database on all of your z/OS® systems, but it must be installed on at least one z/OS® system.

If you choose Db2® for your IBM Z Software Asset Management database, either of the following:

- Db2® for z/OS® Version 12, Release 1 and Db2® Utilities for z/OS®
- Db2® for z/OS® Version 13, Release 1 and Db2® Utilities for z/OS®

If you do not have a Db2® license:

- SQLite, Version 3.27.2, that is embedded in IBM Z Software Asset Management

Contact IBM support in order to install IBM Z Software Asset Management with SQLite only.

- Language Environment® for z/OS®
- Any of the following browsers:
  - Firefox Standard Release 113.0.1 with JavaScript™ and cookies enabled
  - Firefox Extended Support Release 102.11.0 with JavaScript™ and cookies enabled
  - Microsoft™ Edge Version 114.0.1823.11 with JavaScript™ and cookies enabled
  - Internet Explorer, Version 11 with JavaScript™ and cookies enabled
  - Chrome Version 114.0.5735.33
- Microsoft™ Excel 2003

## System configuration requirements

### SMF

The Usage Monitor collects several types of information from SMF records written by the system. It does this by deploying its own IEFU84 SMF exit to gain access to type 30 and type 89 SMF records.

However, this exit will only be given control if IEFU84 is an active SMF exit.

Accordingly, in the system's SMF parameters, ensure that NOEXITS is not specified, and that IEFU84 is specified in any list of SMF exits named in any EXITS parameter which may apply to the started task (STC) or batch job (JES2 or JES3) subsystems.

Also ensure that type 30 and type 89 SMF records are being written by the system, and that SMF interval recording is active for the started task (STC) and batch job (JES2 or JES3) subsystems.

### Inquisitor virtual storage requirements

If you use IEFUSI or SMFLIMxx in PARMLIB to limit data space storage usage, ensure that the Inquisitor can create up to 5 plus MAXTASKS data spaces, and that up to 12GB of data spaces may be allocated. These sizes are a small fraction of the z/OS default limits. The Inquisitor reports data space usage details to provide performance feedback.

## Security and authorization requirements

A z/OS® user ID with appropriate RACF® access is required to submit the batch jobs used in the customizing and operation of IBM Z Software Asset Management . Additional security and authorization configurations can be necessary, depending on your environment.

### RACF® authorizations

The following table lists the RACF® authority required to run IBM Z Software Asset Management Started Tasks, Usage Monitor, Analyzer, and Automation Server. Consult with your RACF® administrator to define the required RACF® authority.

Table 1. RACF® data set access required by each started task

Started task name	SHSIMOD1	PARMLIB	SHSIANL1	SHSIANL2	ACDS	(Db2 only) SDSNLOAD and SDSNEXIT	HLQIDS data set	Usage Monitor output data sets
Usage Monitor	READ	READ	n/a	n/a	n/a	n/a	READ	ALTER
Analyzer	READ	READ	READ	READ	n/a	READ	n/a	n/a
Automation Server	READ	READ	n/a	n/a	CONTROL	n/a	n/a	n/a

The started task should be defined in the resource class STARTED, with additional detail in the STDATA segment of the resource. It can also be defined in the started task table ICHRIN03, but this requires an IPL to add or update a task definition. For example:

```
RDEFINE STARTED HSI*.* UACC(NONE) +
STDATA (USER(uuuuuu))
```

Replace *uuuuuuu* with the name of the started task user for IBM Z Software Asset Management .

```
SETROPTS RACLIST(STARTED) REFRESH
```

When SECURITY=SYSTEM is set for the Analyzer, the application name of HSICANLZ is supplied to SAF during authentication. Security administrators can use permissions to the HSICANLZ resource in the APPL RACF class to control which users are allowed to logon to the Analyzer.

For non-RACF security products, consult your Security Administrator.

## **z/OS® UNIX™ security**

Both the Usage Monitor and the z/OS® UNIX™ Inquisitor need sufficient authority to navigate the UNIX™ file system. The writer task of the Usage Monitor requires access to resolve symbolic links, while the UNIX™ Inquisitor is tasked with discovering executable files.

The HSIPHOST module is called by the Usage Monitor writer task and by both Inquisitor programs to collect the system TCP/IP host name and IP address. This action requires a security user profile which has an associated UNIX uid value. The call of HSIPHOST can be disabled by relevant Usage Monitor and Inquisitor settings, if necessary.

## **APF**

The Inquisitor and Usage Monitor use z/OS® authorized system services. These programs are contained in the PDSE Load Library SHSIMOD1, which must be authorized using APF in order to run the Usage Monitor and/or the Inquisitor when the latter is not being run with PARM=NOAPF.

The Analyzer also requires an APF authorized environment when the SECURITY=SYSTEM option is selected so that it can issue the relevant SAF calls required for user authentication.

## **MEMLIMIT**

The Usage Monitor creates memory objects, which are areas of virtual storage that have addresses greater than 2GB and can only be addressed in 64-bit addressing mode.

The MEMLIMIT setting, which applies to the Usage Monitor address space, must be set at a value high enough to allow the Usage Monitor to create all memory objects necessary for operations. It is recommended that MEMLIMIT=NOLIMIT is used for the Usage Monitor address space.

The actual size of the memory objects that the Usage Monitor creates depends on the SIZ and QSZ settings.

## **Dynamic exits**

Ensure that the EXITS clause in the SMFPRMxx PARMLIB settings that apply to started tasks (STC subsystem) and batch jobs (JES2 or JES3 subsystem) explicitly list IEFU84. The Usage Monitor will install its own IEFU84 SMF exit.

The Usage Monitor will also install its own BPX\_POST\_SYSCALL system exit. If you want to track usage of software written in Java then list BPX1OPN (or BPX4OPN) in the EBCDIC text file named in the SC\_EXITTABLE parameter of active BPXPRMxx PARMLIB settings.

## Db2® authorization

You need Db2® privileges to perform the following tasks:

- DBADM authority to access the product database. You may need to drop and create Db2® resources.
- BIND plans and packages
- EXECUTE authority to execute plans and packages
- SELECT authority to access the Db2® Catalog tables
- LOAD, REPAIR, and STATS privileges to run Db2® utilities LOAD, REPAIR, and RUNSTATS
- GRANT USE OF BUFFERPOOL privilege to use specific buffer pools
- GRANT USE of STOGROUP privilege to use a specific storage group
- ALTER BUFFERPOOL privilege to activate Bufferpool BP8K0. Compressed indexes require Bufferpools of size 8K, 16K, or 32K. Define and activate other Bufferpool names according to site requirements. For sites using Db2 data sharing, group Bufferpools must be defined with the same names.
- Access to work file database or TEMP database for Declared Global Temporary table.

## SQLite authorization

Creating a SQLite database requires authority to perform the following tasks:

- Allocate, format, and mount a zFS file system
- Grant access to z/OS OMVS groups

## Checklist of installation and customization tasks

This checklist includes a set of procedures for installing the product, creating a test database, populating data, and validating the test installation. When you complete these procedures, you are ready to create a production environment for IBM Z Software Asset Management.

**Table 2. Checklist of installation and customization tasks**

Step	Description	Data sets and members
1	Install target libraries.  A z/OS® system programmer performs this task.  <a href="#">Installing target libraries on page 27</a>	hsi= IBM Z Software Asset Management product prefix  <ul style="list-style-type: none"> <li>• hsi.SHSIANL1</li> <li>• hsi.SHSIANL2</li> <li>• hsi.SHSIEXEC</li> <li>• hsi.SHSIGKB1</li> <li>• hsi.SHSIMJPN</li> <li>• hsi.SHSIMOD1</li> <li>• hsi.SHSIPARM</li> </ul>

**Table 2. Checklist of installation and customization tasks (continued)**

Step	Description	Data sets and members
		<ul style="list-style-type: none"> <li>• hsi.SHSIPROC</li> <li>• hsi.SHSISAMP</li> </ul>
2	<p>Prepare database prerequisites.</p> <p>A Db2® database administrator performs this task.</p> <p><a href="#">Preparing Db2 database prerequisites on page 28</a></p> <p>The SQLite database is embedded in IBM Z Software Asset Management and the prerequisites are already configured. If you plan to use the SQLite database for your implementation, you do not have to perform this task.</p>	<p>Db2® SDSNSAMP data set members:</p> <ul style="list-style-type: none"> <li>• DSNTIJTM</li> <li>• DSNTIJCL</li> </ul>
3	<p>Prepare local environment settings.</p> <p>Tasks include editing the HSISCUST member in the SHSISAMP target library, changing the SYSIN DD entry for local settings, and running the HSISCUST job. This job generates JCL jobs that you run in subsequent tasks.</p> <p>A database administrator and a IBM Z Software Asset Management administrator perform this task.</p> <p><a href="#">Preparing local environment settings on page 28</a></p>	<p>hsiinst=hlq for JCLLIB, and PARMLIB libraries</p> <p>hsi.SHSISAMP data set member: HSISCUST generates hsiinst.&amp;DB.JCLLIB hsiinst.&amp;DB.PARMLIB</p>
4	<p>Create a test Repository database.</p> <p>A database administrator and a IBM Z Software Asset Management administrator perform this task.</p> <ul style="list-style-type: none"> <li>• <a href="#">Creating a test Repository database in Db2 on page 33</a></li> <li>• <a href="#">Creating a test Repository database in SQLite on page 34</a></li> </ul>	<p>JCLLIB data set member:</p> <ul style="list-style-type: none"> <li>• HSISDB01</li> <li>• HSISDB02</li> <li>• HSISDB03</li> <li>• HSISGKBL</li> <li>• HSISGRNT</li> </ul>
5	<p>Collect data and import it into the test Repository database.</p> <p>A IBM Z Software Asset Management administrator performs this task.</p> <p><a href="#">Populating the test Repository database with data on page 34</a></p>	<p>JCLLIB data set members:</p> <ul style="list-style-type: none"> <li>• HSISINQZ: Gather Inquisitor data.</li> <li>• HSISINQU: Gather Inquisitor UNIX data.</li> <li>• HSISUMON: Gather Usage Monitor data.</li> </ul>

**Table 2. Checklist of installation and customization tasks (continued)**

Step	Description	Data sets and members
		<ul style="list-style-type: none"> <li>• HSISIQIM: Import Inquisitor data.</li> <li>• HSISUIMP: Import usage data.</li> </ul>
6	<p>Create the production Repository database and arrange for regular maintenance.</p> <ul style="list-style-type: none"> <li>• <a href="#">Creating a production Repository database on page 36</a></li> <li>• <a href="#">Maintaining the production Repository database on page 38</a></li> </ul>	<p>JCLLIB data set members:</p> <ul style="list-style-type: none"> <li>• HSISCUST</li> <li>• HSISDB01</li> <li>• HSISDB02</li> <li>• HSISDB03</li> <li>• HSISGKBL</li> <li>• HSISGRNT</li> <li>• HSISGRTB</li> <li>• HSIJMON</li> <li>• HSIASALC</li> <li>• HSIJAUTO</li> <li>• HSIJANLO</li> <li>• HSISANS1</li> <li>• HSISANS2</li> <li>• HSISANS3</li> <li>• HSISINQZ</li> <li>• HSISINQU</li> <li>• HSISUMON</li> <li>• HSISIQIM</li> <li>• HSISUIMP</li> <li>• HSISUDEL</li> <li>• HSISLDEL</li> <li>• HSISPDEL</li> <li>• HSISTPRM</li> <li>• HSISUN83</li> <li>• HSISLO83</li> <li>• HSISUT01</li> <li>• HSISUT02</li> <li>• HSISUT03</li> <li>• HSISUT04</li> <li>• HSISIVPD</li> </ul> <p>PARMLIB data set members:</p>

**Table 2. Checklist of installation and customization tasks (continued)**

Step	Description	Data sets and members
		<ul style="list-style-type: none"> <li>• HSISMNPM</li> <li>• HSIAPARM</li> <li>• HSISANP1</li> </ul>

## Installing target libraries

Before you can install IBM Z Software Asset Management in a production environment, you can create a test environment.

### Before you begin

The installation must be performed by a z/OS® system programmer who has access to ShopzSeries to download the product.

### Procedure

1. Download IBM Z Software Asset Management , version 8.2 1.1 , and all available maintenance components.
2. Follow the Receive and Apply instructions in the *IBM Z Software Asset Management Program Directory* to install the target libraries.

The following libraries are installed:

Data set low-level qualifier (LLQ)	Description
SHSIANL1	Analyzer reports
SHSIANL2	Java script charting code
SHSIEXEC	REXX code
SHSIGKB1	Global Knowledge base data
SHSIMJPN	Message templates in Japanese.
SHSIMOD1	Load modules
SHSIPARM	Templates that the HSISCUST job uses to populate &HSIINST..PARMLIB library.
SHSIPROC	JCL PROCs
SHSISAMP	Templates that the HSISCUST job uses to populate the &HSIINST..JCLLIB library.

3. Install all PTF maintenance packages.
4. Ensure that the target libraries are available to the LPAR where you intend to configure the test Db2® for z/OS® database.
5. Specify that the SHSIMOD1 data set is authorized by the Authorized Program Facility (APF).

For example, you can enter:

```
SETPROG APF,ADD,DSN=hsi.SHSIMOD1,SMS
```

or

```
SETPROG APF,ADD,DSN=hsi.SHSIMOD1,VOL=xxxxxx
```

- Schedule a change request to roll out target libraries to all z/OS® LPARs where IBM Z Software Asset Management is used and include APF authorization for SHSIMOD1.  
For example, update the appropriate PROGxx member.

## Preparing Db2® database prerequisites

The Db2® environment for the test z/OS® installation has prerequisites that you must configure.

### Before you begin

Db2® database administrator and IBM Z Software Asset Management administrator privileges are required to perform this task.

Db2® for z/OS® must be installed. See [Installation prerequisites on page 21](#). Db2® must have access to a minimum of 1600 cylinders of 3390 DASD space.

All Db2® table spaces defined in IBM Z Software Asset Management are partition-by-growth universal table spaces (UTS). UTS is a combination of partitioned and segmented table space schemes. Non-UTS table space types are deprecated.

### Procedure

- Run the DSNTIJCL job from Db2® SDSNSAMP to bind the DSNACLI plan and enable the Call Library Interface (CLI/ODBC) Db2® plan.

If you encounter a SQL error, code -805, rebind this plan with the latest Db2® maintenance package and include the following package in the job:

```
BIND PACKAGE (DSNAOCLI) MEMBER(DSNCLIMS) - CURRENTDATA(YES) ENCODING(EBCDIC) SQLERROR(CONTINUE)
```

- Run the DSNTIJTM job from Db2® SDSNSAMP to bind the DSNREXX plan and enable the REXX Db2® plan.

## Preparing local environment settings

After installation, you can create a custom version of any job in the JCLLIB library or any parameter in the PARMLIB library, by copying and editing the relevant job in the HSISCUST member in the hsi.SHSISAMP data set.

Depending on your environment, you can define parameters for the following environments:

- Db2®
- SQLite
- Remote configuration

The **DBTYPE** parameter determines the environment and creates the jobs to customize and run the product in that environment.

Review the HSISCUST job parameters before you begin. A database administrator and a system programmer are required to perform the customization. After you make the required changes, submit the job. The JCL creates or reuses two output PDSE libraries and two sequential data sets.

The job creates the following PDSE libraries:

- The JCLLIB library contains Job Control Language (JCL) scripts that implement and operate the product.
- The PARMLIB library contains predefined parameters that the JCL scripts reference.

The job creates the following sequential datasets:

- The UM.HLQIDS sequential data set is referenced by the Usage Monitor on creation, and contains a single record.
- The ZSAMLOCK sequential data set is a dummy file used for serialization.

### General parameters

The following table lists the general parameters that you must consider for all environments.

**Table 3. General customization parameters**

Parameter	Description
SET HSI	You must set this JCL parameter to the high-level qualifiers of the target libraries created by the SMP/E installation process. The default parameter is HSI.V830.
SET ISP	The customization tool uses ISPF services to customize the parameters and JCL for the user. This parameter specifies the high-level qualifiers for the ISPF target libraries. The default parameter begins with ISP.
DBTYPE	This parameter determines the environment and creates the JCL and parameters for that environment: <ul style="list-style-type: none"> <li>• DB2®</li> <li>• SQLITE</li> <li>• REMOTE: The product collects Inquisitor and Usage Monitor data at remote sites and no database is required.</li> </ul>

### Required settings for all database types

The following table lists the required settings for all databases.

**Table 4. Required settings for all databases**

Parameter	Description
CLASS	CLASS
MSGCLASS	JES message class

**Table 4. Required settings for all databases (continued)**

Parameter	Description
MSGLEVEL	JES message level
CEERUN	This parameter specifies the fully qualified Language Environment® CEERUN data set.
CBCDLL	This parameter specifies the fully qualified Language Environment® CBCDLL C++ runtime data set.
HSIINST	<p>This parameter specifies the high-level qualifier of the JCLLIB, PARMLIB, and sequential data sets that are created by running the HSISCUST job. If the JCLLIB and PARMLIB data sets exist, they are reused and members are replaced. The sequential data sets are either created or reused. The name specified for this parameter must be less than, or equal to, 19 characters in length.</p> <p> <b>Note:</b> For SQLite only.</p> <p>If you are migrating from IBM Z Software Asset Management, Version 8.2, use back the same value specified for this parameter. If you use a different value, a new zFS file is created and the migration will fail.</p>

### Settings for Db2® and SQLite databases

The following table lists the settings for Db2® and SQLite databases.

**Table 5. Settings for Db2® and SQLite databases**

Parameter	Description
SYS	System where database resides
REPZSCHM	<p>This parameter is used as a full qualifier for the tables and index definitions in the repository, and as a part qualifier for the tables and index definitions in the local knowledge base, and local knowledge base for z/OS® UNIX®. The REPZSCHM name must be less than, or equal to, 8 characters in length.</p> <p>If you are migrating from IBM Z Software Asset Management Version 8.2, use back the same value specified for this parameter. If you use a different value, the migration will fail.</p>
GKBZSCHM	<p>This parameter is part of the table qualifier and the index definitions qualifier for the GKB, GKB for z/OS® UNIX®, and Inquisitor filters. The GKBZSCHM name must be less than, or equal to, 8 characters in length.</p> <p>If you are migrating from IBM Z Software Asset Management, Version 8.2, use back the same value specified for this parameter. If you use a different value, the migration will fail.</p>

**Table 5. Settings for Db2® and SQLite databases (continued)**

Parameter	Description
DBADMIN	DBADMIN is an optional parameter. For a Db2® database, this parameter specifies the list of user IDs that are granted administrator access to the database and its contents. Specify an empty string if you do not want to grant administrator access to user IDs for the database specified in DB and DBGKB. For SQLite, this parameter specifies the list of user IDs that can connect to the z/OS® RACF® group.
SIZE	This parameter specifies the initial space allocation for Db2® and SQLite table spaces of the three largest tables. The default value of SIZE is 1.

**Db2® database settings**

The following table lists the Db2® database settings.

**Table 6. Db2® database settings**

Parameter	Description
DB	This parameter specifies the name of the repository database that the product uses to store all of the information that it gathers other than from the GKB. The DB name must be less than, or equal to, 8 characters in length.  If you are migrating from IBM Z Software Asset Management, Version 8.2, use back the same value specified for this parameter. If you use a different value, the migration will fail.
DBGKB	This parameter defines a single GKB database that is accessed by multiple repositories under the same Db2® subsystem. The DBGKB name must be less than, or equal to, 8 characters in length, and must not have the same name as the name defined for DB.  If you are migrating from IBM Z Software Asset Management, Version 8.2, use back the same value specified for this parameter. If you use a different value, the migration will fail.
DB2LOAD	This parameter specifies the fully qualified SDSNLOAD data set name.
DB2EXIT	This parameter specifies the fully qualified SDSNEXIT data set name. If the DB2EXIT library does not exist, use the same value as the DB2LOAD parameter.
DBSSID	This parameter specifies the Db2® subsystem ID on the z/OS® system.
LOC	This parameter specifies the CLI/ODBC location for the Db2® subsystem ID on the z/OS® system. You can use the DB2® DISPLAY DDF command to determine the location.
SETSQLID	This parameter is used in SET CURRENT SQLID to allow a different user to define Db2® objects. This parameter is optional. The SETSQLID value must be less than, or equal to, 8 characters in length.

**Table 6. Db2® database settings (continued)**

Parameter	Description
SGHSITAB	This parameter specifies the storage group name for small tables in the database. The default value is SGHSITAB (same as the parameter name). Consult your Db2® database administrator for security implications and naming conventions. See the SQL statement CREATE STOGROUP for more information.
SGHSIBIG	This parameter specifies the storage group name for large tables in the database. The default value is SGHSIBIG (same as the parameter name). Consult your Db2® database administrator for security implications and naming conventions. See the SQL statement CREATE STOGROUP for more information.
SGHSIIDX	This parameter specifies the storage group name for indexes in the database. The default value is SGHSIIDX (same as the parameter name). Consult your Db2® database administrator for security implications and naming conventions. See the SQL statement CREATE STOGROUP for more information.
SGTABCAT	This parameter specifies the VCAT of the Db2® table space data set names for small tables in the database. Consult your Db2® database administrator for security implications and disk storage requirements. This parameter is referenced by storage group name parameter SGHSITAB.
SGTABVOL	This parameter specifies the names of the volumes that the table space data sets for small tables are allocated on. This parameter is referenced by storage group name parameter SGHSITAB.
SGBIGCAT	This parameter specifies the VCAT of the Db2® table space data set names for large tables in the database. Consult your Db2® database administrator for security implications and disk storage requirements. This parameter is referenced by storage group name parameter SGHSIBIG.
SGBIGVOL	This parameter specifies the names of the volumes that the table space data sets for large tables are allocated on. This parameter is referenced by storage group name parameter SGHSIBIG.
SGIDXCAT	This parameter specifies the VCAT of the Db2® data set names for indexes in the database. Consult your Db2® database administrator for security implications and disk storage requirements. This parameter is referenced by storage group name parameter SGHSIIDX.
SGIDXVOL	This parameter specifies the names of the volumes that the data sets, for indexes, are allocated on. This parameter is referenced by storage group name parameter SGHSIIDX.

**Table 6. Db2® database settings (continued)**

Parameter	Description
<ul style="list-style-type: none"> <li>• BPDB</li> <li>• BPTS</li> <li>• BPIX</li> </ul>	These parameters specify the buffer pool definitions for the database, table spaces, and indexes. For BPIX, the buffer pool size must be defined as 8K, 16K, or 32K.

### SQLite database settings

The following table lists SQLite database settings.

**Table 7. SQLite database settings**

Parameter	Description
SQLTZFS	<p>The name of a zFS linear VSAM data set that is used for IBM Z Software Asset Management SQLite databases.</p> <p>If you are migrating from IBM Z Software Asset Management, Version 8.2, use back the same value specified for this parameter. If you use a different value, the migration will fail.</p>
SQLTPATH	<p>z/OS UNIX System Services directory where the SQLTZFS data set is mounted. The HSIADB01 job in JCLLIB creates this path at a later time.</p> <p>If you are migrating from IBM Z Software Asset Management, Version 8.2, use back the same value specified for this parameter. If you use a different value, the migration will fail.</p>

### Configuring a test Repository database

Configuring the test Repository database includes setting up database objects, creating the Global Knowledge Base (GKB) database, and configuring access to the Repository and the GKB databases. Most sites maintain both a test Repository database and a production Repository database. After you configure and validate the test Repository database, repeat this task to create the production Repository database.

### Creating a test Repository database in Db2®

Creating the IBM Z Software Asset Management database includes setting up storage groups, the database name, and the administrator logon details. You also create the Global Knowledge Base (GKB) environment and then grant access to the database.

### Procedure

1. Run the HSIADB01 job to create the storage groups.
2. Run the HSIADB02 job to create the database objects for the Global Knowledge Base (GKB).
3. Run the HSIADB03 job to create the Repository database and database objects.



**Note:** Before running this job, review the comments in the job. In member HSISSQ18 of the PARMLIB library, the COMPRESS keyword is set for all indexes. Bufferpool BP8K0 must first be activated in Db2® before these compressed indexes can be created. Rename and activate different Bufferpool names according to site requirements.

4. Run the HSISGKBL job to load the GKB.
5. Run the HSISGRNT job to grant DBADMIN access to the IBM Z Software Asset Management administrator to the Repository and the GKB databases.

## Creating a test Repository database in SQLite

Creating the test Repository database includes allocating, formatting, and mounting a zFS file system and also granting access to z/OS® OMVS groups. This is followed by creating the database name and administrator logon details.

### Procedure

1. Run the HSISDB01 job to allocate, format, and mount a zFS file system.
2. Run the HSISDB02 job to create the database objects for the Global Knowledge Base (GKB).
3. Run the HSISDB03 job to create the Repository database and database objects.
4. Run the HSISGKBL job to load the GKB.
5. Run the HSISGRNT job to grant access to the z/OS® OMVS groups that the IBM Z Software Asset Management administrator is a member of.

## Populating the test Repository database with data

You can populate the test Repository database in stages. Begin by collecting and importing Inquisitor and Usage Monitor data on the local LPAR, and then verify that this process is successful before collecting and importing data from other LPARs.

## Collecting and importing data to the test Repository database

After creating the databases and database objects, you are ready to collect Inquisitor and Usage Monitor data. You can then import the collected data into the test Repository database.

### Procedure

1. Run the HSISINQZ job to scan the DASD for z/OS® product modules and generate output to the DD HSIPZIP output file.  
For large sites, this operation can take up to an hour. You can perform step 3 on page 34 while the job is running.
2. Run the HSISINQU job to scan z/OS® UNIX files and generate output to the DD HSIXZIP output file.  
For large sites, this operation can take up to an hour. You can perform step 3 on page 34 while the job is running.
3. To run the Usage Monitor to gather initial usage data, perform the following tasks:

- a. Run the HSIJMON job to start the Usage Monitor as a batch job.  
The Usage Monitor is typically run as a started task, but you can run it as a batch job for this test. This job runs continually until you stop it manually and most of the time this job is idle.

- b. Stop the Usage Monitor to generate the `hsiinst.UM&SMF.D*.T*` output file.

For example, enter the following command to stop the started task:

```
P HSIJMON
```

4. To import Inquisitor (IQ) data into the test Repository database, perform the following tasks:

- a. Verify that the HSIINQZ and HSIINQU jobs that you started in steps [1 on page 34](#) and [2 on page 34](#) have completed.

If the jobs are still running, wait until they are completed.

The output logs from these jobs provide information on the number of records collected.

- b. Run the HSIQIM job to import the data from the HSIPZIP and HSIUZIP output files that were created by the HSIINQZ and HSIINQU jobs.

For large sites, this job can take more than two hours to run the first time. Performance is significantly faster on subsequent runs.

5. Run the HSIUIMP job to import usage data from the `hsiinst.UM&SMF.D*.T*` file.

## Verifying the results of the data import with the Analyzer

After you complete the collection and import of Inquisitor and Usage Monitor data, use the Analyzer to verify that the import was successful.

### Procedure

1. Review the HSIANP1 PARMLIB library settings and modify if necessary.

These settings specify the IBM Z Software Asset Management administrator user ID and password.

2. Run the HSIANLO JCLLIB job on the test Repository database.

This job, typically, runs continually but you can enter the `F HSIANLO, STOP` command to stop it.

3. On your PC browser, logon to the Analyzer utility with the values specified in member HSIANP1 of PARMLIB library.

4. Review the Analyzer reports to confirm that all expected products have been identified.

If a product is missing, perform the following tasks to identify the reason why a product is not included:

- Check that the product is in the GKB and report any missing product to IBM support so that they can provide an updated GKB for the product.
- If the product exists in the GKB, check that the product is installed on the test z/OS®. If the product is not installed on the test z/OS®, run the Inquisitor utility on a system where the product is installed and then import that data into the test database.

## Collecting and importing data from other systems

After you verify that all components are correctly installed on the test Repository database, you can now discover and import Inquisitor and Usage Monitor data from other z/OS® logical partitions (LPARs).

### Procedure

1. Run the following jobs to collect Inquisitor and Usage data from other systems:
  - a. Run the HSISINQZ job to scan all other LPARs and generate output to the `hsiinst.HSIPZIP.Z&SMF` file.
  - b. Run the HSISINQU job and generate output to the `hsiinst.HSIUZIP.U&SMF` file.
  - c. Run the HSISUMON job to start the Usage Monitor as a batch job on the other LPARS.
2. Transfer collected data to the central site via file transfer protocol (FTP).
3. Run the following jobs to import Inquisitor and Usage data at the central site:
  - a. Run the HSISIQIM job to import Inquisitor data from the `hsiinst.HSIPZIP.Z&SMF` and `hsiinst.HSIUZIP.U&SMF` files for each LPAR.
  - b. Run the HSISUIMP job to import Usage data from the `hsiinst.UM&SMF.D*.T*` file for each LPAR.

## Configuring a production Repository database

Most implementations include a test Repository database and a production Repository database. Configuring a production Repository database involves creating the database and importing data, configuring security, and automating data collection activities

### Creating a production Repository database

The production Repository database runs on a development logical partition (LPAR), and it is not necessary to run it on a business workload LPAR. You can duplicate the content of test Repository database to populate production Repository database without collecting and importing Inquisitor and Usage Monitor data again.

### About this task

You can create the production Repository database on a Db2® or SQLite database. This procedure combines instructions for both database environments. See [Configuring a test Repository database on page 33](#) for database-specific instructions.

### Procedure

1. Run the HSISDB01 job.
  - For Db2®, the job creates storage groups.
  - For SQLite, the job allocates the zFS file system.
2. Run the HSISDB02 job to create the database objects for the Global Knowledge Base (GKB).
3. Run the HSISDB03 job to create the Repository database and database objects.



**For Db2 databases:** Before running the HSISDB03 job, review and change definitions in PARMLIB members HSISSQ17 and HSISSQ18 as needed to meet site requirements:



- In member HSISSQ17 of PARMLIB library, use the MAXPARTITIONS parameter to increase the number of partitions for the three largest table spaces (VMODULE, VUSEMTD, and VPRODDT) according to site requirements.
- In member HSISSQ18 of the PARMLIB library, the COMPRESS keyword is set for all indexes. Bufferpool BP8K0 must first be activated in Db2® before these compressed indexes can be created. Rename and activate different Bufferpool names according to site requirements.

4. Run the HSISSGKBL job to load the GKB.
5. Run the HSISSGRNT job.
  - For Db2®, the job grants DBADMIN access to the IBM Z Software Asset Management administrator for the Repository and GKB databases.
  - For SQLite, the job grants access to the z/OS® OMVS groups.
6. Run the HSISSGRTB job.
 

For Db2®, this job grants SELECT access to database tables.
7. To populate the production Repository database, repeat the procedure for collecting and importing data that you performed to populate the test Repository database.

## What to do next

Configure security for the production Repository database.

### Configuring security for the production Repository database

Resource Access Control Facility (RACF®) security provides authentication, authorization, and auditing control for working with z/OS® systems.

## Procedure

1. Define a profile in the STARTED class to associate a user ID with the HSIJMON, HSIJAUTO, and HSIJANLO started tasks.
2. Specify that user IDs have the following access permissions:
  - a. READ access to `hsi**` data sets
  - b. ALTER access to `hsiinst.**` data sets

## What to do next

Configure the automation of data collection activities on the production Repository database.

### Automating data collection and reporting activities

When you configure the Usage Monitor, the Automation Server, and the Analyzer to run as started tasks, these data collection and reporting activities are automated.

## Procedure

1. Configure the Usage Monitor utility to start automatically:
  - a. In the HSISMNPM member of the PARMLIB data set, modify settings if necessary so that the **DSN(hsiinst.UM&SMF)** command generates hsiinst.UM&SMF.D\*.T\* data sets.
  - b. Schedule a change request to roll out the new HSIJMON started task on all z/OS® LPARs.
  - c. Copy the HSIJMON started task from the JCLLIB library to the system PROCLIB data set.
  - d. Arrange for the HSIJMON started task to start early in the initial program load (IPL) cycle to ensure that all usage activity is recorded.
2. Configure the Automation Server utility to start automatically and to automate data collection and import tasks:
  - a. Schedule a change request to roll out a new HSIJAUTO started task on all z/OS® LPARs.
  - b. Run the HSIASALC job to define the automation control Virtual Storage Access Method (VSAM) data set.
  - c. Configure the HSIAPARM settings to perform the following tasks every weekend:
    - Remote hosts: Runs an Inquisitor scan job to collect data, runs the ZCAT to amalgamate usage data, and transfers collected data via file transfer protocol (FTP).
    - Database host: Runs an Inquisitor Import job, runs a usage import job, and aggregates the data.
  - d. If necessary, run the HSIASSCT job to mark existing data sets as being already processed in the automation control data set.
  - e. Copy the HSIJAUTO started task from the JCLLIB library to the system PROCLIB data set.
  - f. Arrange for the HSIJAUTO to start automatically at any time in the IPL cycle.
3. Configure the Analyzer utility to start automatically:
  - a. Schedule a change request to roll out the new HSIJANLO started task to the production database host.
  - b. Copy the HSIJANLO started task from the JCLLIB data set to the system PROCLIB data sets.
4. Configure the Analyzer utility to work with a secure socket layer (SSL) for HTTPS transport and to logon with a RACF® user ID and password:
  - a. In the HSISANP2 member of the PARMLIB data set, change the security parameter to SECURITY=SYSTEM,
  - b. Review and edit the comments in the HSISANS1, HSISANS2, and HSISANS3 members of the JCLLIB data set to create a digital certificate that is required for SSL.
  - c. Configure the HTTPPORT parameter, if you require a value other than the default value.
  - d. Review the Analyzer reports to confirm that all expected products are identified.

## Maintaining the production Repository database

You must perform regular maintenance tasks on the production Repository database to ensure optimal performance. The maintenance tasks cull obsolete and unwanted data and reorganize the database as necessary.

## About this task

A database administrator or system programmer performs these maintenance tasks.

## Procedure

1. Run the following jobs on a regular basis to delete old usage data, save space, and improve processing time:
  - a. Run the HSIUDEL job to delete usage data that are older than a specified period.
  - b. Run the HSISLDEL job to delete obsolete discovery and usage data for a specified system (LPAR).
  - c. Run the HSISPDEL job to physically delete data for all systems.
  - d. Run the HSISTPRM job to reset the status flag back to normal for tables in the production Repository database, following a failure.
  - e. Run the HSIIVP job to verify database changes since the product was released.
2. Run the following jobs on a regular basis to maintain the integrity and performance of data in the production Repository database:
  - a. Run the HSIUT01 job to backup the Repository database in Db2® or backup the zFS file system in SQLite.
  - b. Run the HSIUT02 job to restore the Repository database in Db2® or restore the zFS file system in SQLite.
  - c. Run the HSIUT03 job to reorganize the Repository database in Db2®.
  - d. Run the HSIUT04 job to update RUNSTATS statistics for the Repository database in Db2®.

# Chapter 4. Implementing deployment scenarios

Most implementations of IBM Z Software Asset Management are based on one of the common deployment scenarios. An example is provided for implementing each of these common deployment scenarios with a Db2® Repository database. You can adapt an example for use with a SQLite Repository database.

---

Related information

[Planning for deployment on page 17](#)

## Scenario 1: Implementing a single Repository database with a single GKB database

The most common deployment scenario is an implementation with a single Repository database and a single global knowledge base (GKB) database.

### About this task

The example deployment is for a Db2® database environment and includes the key parameters that influence this scenario.

### Procedure

1. Customize an instance of the HSISCUST member in the hsi.SHSISAMP data set with the following parameters:
  - **DBTYPE**=DB2
  - **REPZSCHM**=REPHLQ1
  - **GKBZSCHM**=GKBHLQ1
  - **DB**=REPDB1
  - **DBGKB**=GKBDB1
2. Submit the HSISCUST job.
3. Create the Repository and GKB databases and grant access to them:
  - a. Run the HSISDB01 job to create storage groups.
  - b. Run the HSISDB02 job to create the GKB database and database objects.
  - c. Run the HSISDB03 job to create the Repository database and database objects.
  - d. Run the HSISGKBL job to load GKB data.
  - e. Run the HSISGRNT job to grant DBADMIN access to IBM Z Software Asset Management administrator.
  - f. Run the HSISGRTB job to grant SELECT access to database tables.
4. Collect Inquisitor and Usage Monitor data:
  - a. Run the HSISINQZ job on all z/OS® LPARs to collect Inquisitor data.
  - b. Run the HSISINQU job on all z/OS® LPARs to collect Inquisitor data for UNIX®.

- c. Run the HSISUMON job on all z/OS® LPARs to collect usage data.
  - d. Run the HSISZCAT job to condense usage data, separately for each z/OS LPAR (if there are usage data from 3 LPARs, then there should be 3 condensed output files).
5. Transfer the collected Inquisitor and condensed ZCAT usage data to the central site via file transfer protocol (FTP).
  6. Import Inquisitor and Usage Monitor data at the central site:
    - a. Run the HSISIQIM job to import Inquisitor data into the Repository database for each LPAR.
    - b. Run the HSISUIMP job to import Usage data into the Repository database for each LPAR.

## Scenario 2: Implementing multiple Repositories with a shared GKB database

This deployment scenario implements two Repositories in a single Db2® subsystem that share a single global knowledge base (GKB) database. The advantage of sharing the same GKB is that you need only apply monthly updates to a single GKB database.

### About this task

The example deployment is for two Repositories in the same Db2® subsystem to enable the Analyzer to browse both Repositories at the same time.

### Procedure

1. Customize an instance of the HSISCUST member in the hsi.SHSISAMP data set with the following parameters.
  - **DBTYPE**=DB2
  - **REPZSCHM**=REPHLQ1
  - **GKBZSCHM**=GKBHLQ1
  - **DB**=REPDB1
  - **DBGKB**=GKBDB1
2. Submit the HSISCUST job.
3. Create the Repository and GKB database and grant access to them:
  - a. Run the HSISDB01 job to create storage groups.
  - b. Run the HSISDB02 job to create the GKB database and database objects.
  - c. Run the HSISDB03 job to create the Repository database and database objects.
  - d. Run the HSISGKBL job to load GKB data.
  - e. Run the HSISGRNT job to grant DBADMIN access to IBM Z Software Asset Management administrator.
  - f. Run the HSISGRTB job to grant SELECT access to database tables.
4. Collect Inquisitor and Usage Monitor data to:
  - a. Run the HSISINQZ job on all z/OS LPARs to collect Inquisitor data.
  - b. Run the HSISINQU job on all z/OS LPARs to collect Inquisitor data for UNIX®.

- c. Run the HSISUMON job on all z/OS LPARs to collect usage data.
  - d. Run the HSISZCAT job to condense usage data, separately for each z/OS LPAR (if there are usage data from 3 LPARs, then there should be 3 condensed output files).
5. Transfer the collected Inquisitor and condensed ZCAT usage data to the central site via file transfer protocol (FTP).
6. Import Inquisitor and Usage Monitor data at the central site:
  - a. Run the HSISIQIM job to import Inquisitor data into the Repository database for each LPAR.
  - b. Run the HSISUIMP job to import Usage data into the Repository database for each LPAR.
7. Customize another instance of the HSISCUST member in the hsi.SHSISAMP data set with the following parameters:
  - **DBTYPE**=DB2
  - **REPZSCHM**=REPHLQ2
  - **GKBZSCHM**=GKBHLQ1
  - **DB**=REPDB2
  - **DBGKB**=GKBDB1
8. Submit the HSISCUST job.
9. Create the second Repository and grant access to it: It is not necessary to run jobs to create and populate the GKB database in this step because the second Repository shares the GKB that was created in steps 3b and 3d.
  - a. Run the HSISDB01 job to create storage groups.
  - b. Run the HSISDB03 job to create the Repository database and database objects.
  - c. Run the HSISGRNT job to grant DBADMIN access to IBM Z Software Asset Management administrator.
  - d. Run the HSISGRTB job to grant SELECT access to database tables.
10. Collect Inquisitor and Usage Monitor data to add to the second Repository database:
  - a. Run the HSISINQZ job on all z/OS LPARs to collect Inquisitor data.
  - b. Run the HSISINQU job on all z/OS LPARs to collect Inquisitor data for UNIX.
  - c. Run the HSISUMON job on all z/OS LPARs to collect usage data.
  - d. Run the HSISZCAT job to condense usage data, separately for each z/OS LPAR (if there are usage data from 3 LPARs, then there should be 3 condensed output files).
11. Transfer the collected Inquisitor and condensed ZCAT usage data to the central site via file transfer protocol (FTP).
12. Import Inquisitor and Usage Monitor data at the central site:
  - a. Run the HSISIQIM job to import Inquisitor data into the second Repository database for each LPAR.
  - b. Run the HSISUIMP job to import Usage data into the second Repository database for each LPAR.

## What to do next

Repeat steps 7-12 for each additional Repository that you want to create, changing the values for the **REPZSCHM** and **DB** parameters for each new Repository.

## Scenario 3: Implementing multiple Repositories with multiple GKB databases

This deployment scenario implements two Repositories in a single Db2® subsystem, each with its own global knowledge base (GKB) database. This deployment scenario is not common because you must apply monthly updates to each GKB database.

## About this task

The example deployment is for two Repositories in the same Db2® subsystem to enable the Analyzer to browse both Repositories at the same time.

## Procedure

1. Customize an instance of the HSISCUST member in the hsi.SHSISAMP data set with the following parameters:
  - **DBTYPE**=DB2
  - **REPZSCHM**=REPHLQ1
  - **GKBZSCHM**=GKBHLQ1
  - **DB**=REPDB1
  - **DBGKB**=GKBDB1
2. Submit the HSISCUST job.
3. Create the first Repository and GKB database, and grant access to them:
  - a. Run the HSISDB01 job to create storage groups.
  - b. Run the HSISDB02 job to create the GKB database and database objects.
  - c. Run the HSISDB03 job to create the Repository database and database objects.
  - d. Run the HSISGKBL job to load GKB data.
  - e. Run the HSISGRNT job to grant DBADMIN access to IBM Z Software Asset Management administrator.
  - f. Run the HSISGRTB job to grant SELECT access to database tables.
4. Collect Inquisitor and Usage Monitor data:
  - a. Run the HSISINQZ job on all z/OS LPARs to collect Inquisitor data.
  - b. Run the HSISINQU job on all z/OS LPARs to collect Inquisitor data for UNIX.
  - c. Run the HSISUMON job on all z/OS LPARs to collect usage data.
  - d. Run the HSISZCAT job to condense usage data, separately for each z/OS LPAR (if there are usage data from 3 LPARs, then there should be 3 condensed output files).
5. Transfer the collected Inquisitor and condensed ZCAT usage data to the central site via file transfer protocol (FTP).
6. Import Inquisitor and Usage Monitor data at the central site:
  - a. Run the HSISIQIM job to import Inquisitor data into the second Repository database for each LPAR.
  - b. Run the HSISUIMP job to import Usage data into the second Repository database for each LPAR.
7. Customize another instance of the HSISCUST member in the hsi.SHSISAMP data set with the following parameters:
  - **DBTYPE**=DB2
  - **REPZSCHM**=REPHLQ2
  - **GKBZSCHM**=GKBHLQ2
  - **DB**=REPDB2
  - **DBGKB**=GKBDB2
8. Submit the HSISCUST job.
9. Create the second Repository and second GKB database, and grant access to them:
  - a. Run the HSISDB01 job to create storage groups.
  - b. Run the HSISDB02 job to create the GKB database and database objects.
  - c. Run the HSISDB03 job to create the Repository database and database objects.
  - d. Run the HSISGKBL job to load GKB data.

- e. Run the HSIAGRNT job to grant DBADMIN access to IBM Z Software Asset Management administrator.
  - f. Run the HSIAGRTB job to grant SELECT access to database tables.
10. Collect Inquisitor and Usage Monitor data for the second Repository database:
    - a. Run the HSIINQZ job on all z/OS LPARs to collect Inquisitor data.
    - b. Run the HSIINQU job on all z/OS LPARs to collect Inquisitor data for UNIX.
    - c. Run the HSIUMON job on all z/OS LPARs to collect usage data.
    - d. Run the HSIZCAT job to condense usage data, separately for each z/OS LPAR (if there are usage data from 3 LPARs, then there should be 3 condensed output files).
  11. Transfer the collected Inquisitor and condensed ZCAT usage data to the central site via file transfer protocol (FTP).
  12. Import Inquisitor and Usage Monitor data at the central site:
    - a. Run the HSIQIM job to import Inquisitor data into the second Repository database for each LPAR.
    - b. Run the HSIUIMP job to import Usage data into the second Repository database for each LPAR.

## What to do next

Repeat steps 7-12 for each additional Repository and GKB database that you want to create, changing the values for **REPZSCHM**, **GKBZSCHM**, **DB**, and **DBGKB** parameters for each new Repository and GKB database.

## Scenario 4: Collecting and transferring Inquisitor and usage data from remote sites

This scenario extends each of the deployment scenarios to collect data from remote sites and transfer the data back to the central site for processing.

### Procedure

1. At the remote site, install the target libraries.
2. Customize an instance of the HSISCUST member in the hsi.SHSISAMP data set with the following parameter:
 

```
DBTYPE=REMOTE
```
3. Submit the HSISCUST job.
4. Collect Inquisitor and Usage Monitor data and transfer the files to the central site for processing:
  - a. Run the HSIINQZ job on all z/OS® LPARs to collect Inquisitor data.
  - b. Run the HSIINQU job on all z/OS® LPARs to collect Inquisitor data for UNIX®.
  - c. Run the HSIUMON job on all z/OS® LPARs to collect usage data.
  - d. Transfer the collected Inquisitor and Usage Monitor data to the central site using file transfer protocol (FTP).

## Scenario 5: Implementing in a sysplex environment

This deployment scenario is for a sysplex environment, where the DASD is fully shared across all z/OS® LPARs that belong to the sysplex. This special deployment is similar to the deployment scenarios 1, 2, or 3, but the implementation steps are slightly different. This approach is intended to achieve operational efficiency by processing only a single z/OS® LPAR within a sysplex.

## About this task

The example deployment is for a Db2® database environment and includes the key parameters that influence this scenario. For this scenario, assume that the sysplex contains four z/OS® LPARs: MVSA, MVSB, MVSC, and MVSD.

## Procedure

1. Customize an instance of the HSISCUST member in the hsi.SHSISAMP data set with the following parameters:
  - **DBTYPE**=DB2
  - **REPZSCHM**=REPHLQ1
  - **GKBZSCHM**=GKBHLQ1
  - **DB**=REPDB1
  - **DBGKB**=GKBDB1
2. Submit the HSISCUST job.
3. Create the Repository and GKB databases and grant access to them:
  - a. Run the HSISDB01 job to create storage groups.
  - b. Run the HSISDB02 job to create the GKB database and database objects.
  - c. Run the HSISDB03 job to create the Repository database and database objects.
  - d. Run the HSISGKBL job to load GKB data.
  - e. Run the HSISGRNT job to grant DBADMIN access to IBM Z Software Asset Management administrator.
  - f. Run the HSISGRTB job to grant SELECT access to database tables.
4. Run the HSISINQZ job on all four z/OS® LPARs to collect Inquisitor data: MVSA, MVSB, MVSC, and MVSD. The default setting is PLX=N.
  - a. Run the HSISINQZ job on all four z/OS® LPARs to collect Inquisitor data: MVSA, MVSB, MVSC, and MVSD. The default setting is PLX=N.
  - b. Transfer the collected Inquisitor data to the central site via file transfer protocol (FTP).
  - c. Run the HSISIQIM job to import Inquisitor data into the Repository database for each z/OS® LPAR.
5. Collect and import Inquisitor data only for a single z/OS® LPAR in subsequent scans.
  - a. Set **PLX=Y** in the Inquisitor HSISINQZ job.
  - b. Run the HSISINQZ job on any z/OS® LPAR to collect Inquisitor data. The z/OS® LPAR could be MVSA, MVSB, MVSC, or MVSD.
  - c. Transfer the collected Inquisitor data to the central site via FTP.
  - d. Run the HSISIQIM job to import Inquisitor data into the Repository database for the z/OS® LPAR, where you previously ran HSISINQZ.
  - e. Repeat steps a - d for any z/OS® LPAR - MVSA, MVSB, MVSC, or MVSD, every time a new scan is required.



**Note:** It is very important to understand that setting PLX=Y will work in IZSAM only if all LPARs belonging to a sysplex have DASD volumes that are 100% shared. If one LPAR contains DASD volumes that are unique to that LPAR, then PLX=Y must NOT be used. Instead PLX=N must be set and run separately for all LPARs belonging to the sysplex.

6. Collect and import Inquisitor data for UNIX for all z/OS® LPARs the first time:
  - a. Run the HSIINQU job on all four z/OS® LPARs to collect Inquisitor data for UNIX®.
  - b. Transfer the collected Inquisitor data for UNIX® to the central site via FTP.
  - c. Run the HSIQIM job to import Inquisitor data for UNIX® into the Repository database for each z/OS® LPAR.
7. Collect and import Inquisitor data for UNIX only for a single z/OS® LPAR in subsequent scans:
  - a. Set **PLX=Y** in the Inquisitor HSIINQU job.
  - b. Run the HSIINQU job on the first z/OS® LPAR, MVSA, to collect Inquisitor data for UNIX.
  - c. Transfer the collected Inquisitor data to the central site via FTP.
  - d. Run the HSIQIM job to import Inquisitor data for UNIX into the Repository database for the z/OS® LPAR MVSA only.
  - e. Repeat steps a - d for z/OS® LPAR MVSA every time a new scan is required.
8. Collect and import Usage Monitor data:
  - a. Run the HSIUMON job on all z/OS® LPARs to collect usage data.
  - b. Transfer the collected Usage Monitor data to the central site via FTP.
  - c. Run the HSIUIMP job to import Usage data into the Repository database for each LPAR.

# Chapter 5. Migrating to IBM Z Software Asset Management Version 8.2 1.1

When you migrate to the latest version of IBM Z Software Asset Management from an earlier version, you must convert existing data to be compatible with your new environment.

## Migrating to IBM Z Software Asset Management from an earlier version

You can upgrade to IBM Z Software Asset Management, Version 8.2 1.1 from Tivoli® Asset Discovery for z/OS® version 8.1 on either a Db2® Repository database or an SQLite database. Migration from earlier releases is not supported.

### Migrating from version 8.1 to Version 8.2 1.1 (Db2® database)

When you upgrade to IBM Z Software Asset Management version 8.2 for Db2 database, there is porting of data within the Repository database. New Db2 objects are defined and obsolete objects dropped from the Repository. The existing version 8.1 GKB database is dropped and re-created with the same database name for version 8.2.

### Before you begin

Make a backup of your version 8.1 Repository database by running job HSIUT01 from your version 8.1 JCLLIB, or equivalent in-house backup job.

Make a backup or rename your JCLLIB and PARMLIB data sets.

#### Migration planning and consideration:

1. All table spaces from version 8.1 are migrated to version 8.2 partition-by-growth Universal Table Spaces (UTS). These UTS are defined as 'COMPRESS YES'. All indexes are also defined as 'COMPRESS YES' with the BP8K0 as the default buffer-pool.  
  
If you prefer to define some table spaces as partition-by-range UTS, you need to customize some PARMLIB members, before the migration.
2. If your existing version 8.1 Repository database (including LKB/LKU) still use the original table space definitions (segmented non-UTS), then you can use the migration jobs listed below for the migration.
3. If your existing version 8.1 Repository database (including LKB/LKU) already have some or all table spaces reconfigured as UTS, then you need to review and decide which migration jobs are required for the migration. After migration you need to customise version 8.2 JCLLIB/PARMLIB members to reflect your preferred table space names.
4. If your existing version 8.1 Repository database (including LKB/LKU) and GKB use different schema names, then you need to modify the migration jobs to suit your site requirements.
5. The version 8.2 Usage Monitor job/started task (HSISUMON/HSIJMON) requires a minimum level of z/OS V2.3 or later. It will fail if run in z/OS V2.2 or earlier.



**Note:** If your repository is located on an LPAR running at z/OS V2.2 or earlier, the Usage Monitor job/start task (HSISUMON/HSIJMON) must continue to run with version 8.1 load library hsi.SHSIMOD1. You can still



migrate the repository and GKB databases to version 8.2 (depending on types of deployment scenarios described later in the list). Once you have upgraded to z/OS V2.3 or later, you can then run the Usage Monitor with the version 8.2 load library hsi.SHSIMOD1.

6. If you have multiple version 8.1 repositories sharing the same version 8.1 GKB database, you need to phase the migration process.

**A version 8.2 repository must use a version 8.2 GKB.**

**A version 8.1 repository must use a version 8.1 GKB.**



**Note:** Version 8.2 code fails when accessing a version 8.1 GKB database, due to newly defined version 8.2 tables and columns. Conversely, version 8.1 code fails when accessing a version 8.2 GKB database due to differences in version 8.2 table layouts.

For example, if you have version 8.1 repositories REP1, REP2, REP3, and REP4 sharing the same version 8.1 GKB, then migrate as follows:

- To migrate the first repository, REP1, in version 8.2 customization job, HSISCUST, create a new V8.2 GKB database. For example, GKB82.

Customize parameters DBGKB and GKBZSCHM with different names from those used in version 8.1 GKB database. Repository parameter settings and values remain the same.

- Migrate REP1 and GKB database (GKB82) to version 8.2 at the same time. Operational jobs for repository REP1 must now reference the version 8.2 load library hsi.SHSIMOD1.
- The remaining REPs continue to run at version 8.1 with operational jobs still referencing the version 8.1 load library hsi.SHSIMOD1. These REPs continue to use the version 8.1 GKB database (GKB81).
- Gradually migrate the remaining three repositories without creating another version 8.2 GKB (GKB82).
- Once all REPs are migrated and are using the version 8.2 GKB database (GKB82), the version 8.1 GKB (GKB81) database can be dropped.

7. If each repository has its own GKB, then migrate the Repository database, GKB database and hsi.SHSIMOD1 to version 8.2 all at the same time.

8. Housekeeping:

Perform housekeeping on the version 8.1 Repository database before you start your migration process. This should reduce the time required to migrate all the data.

- a. **HSISLDEL** - If you have any obsolete LPARs in the repository, you should delete the obsolete LPARs by running job HSISLDEL.
- b. **HSISPDEL** - TMODULE is one of the biggest tables and it contains modules of which a huge percentage are in-house programs. To delete obsolete modules (especially in-house programs), refer to job HSISPDEL. You need to define a date range for deletion and a sample SQL statement is provided in the job to list date ranges. HSISPDEL deletes modules based on any load libraries that have been marked deleted.
- c. **HSISUDEL** - TUSEMTD is the largest table. Performing housekeeping on this table should be part of best practices.

To determine the status of this table, run the following SQL statement:

```
SELECT FPERIOD, COUNT(*) FROM &RESPZSCHM.TUSEMTD
GROUP BY FPERIOD ;
```

Next, in the Usage Deletion job HSIUDEL, select the date range for deletion. Follow the instructions in the job – if you have never deleted before, you should delete Usage records in increments. Do it for all LPARs. Run the SQL statement again to check the number of outstanding records in TUSEMTD.

A good guideline on the number of records to be retained is to run HSIUDEL monthly for all LPARs with a fixed set of parameter settings:

KEEPDETAIL=3 (or 6)

KEEPAGGR=12

This will retain detailed Usage records for the current month and the previous 3 (or 6) months, and summarized records for the current month and the previous 12 months.

9. Continue to run your version 8.1 Usage Monitor job/started task (HSISUMON/HSIJMON), but stop the Analyzer and do not run any version 8.1 operational jobs during the migration.

## About this task

Perform these migration tasks for every Db2 Repository in your IBM Z Software Asset Management environment.

## Procedure

1. In IBM Z Software Asset Management version 8.2, make a copy of the HSISCUST member in the hsi.SHSISAMP data set and modify the following parameters:
  - a. Set the value of the new **DBTYPE** parameter to DB2.
  - b. Set **HSIINST** to a different value to the one defined for the existing 8.1 system. This will ensure that the JCLLIB/PARMLIB datasets are created with different names. As stated in the section, “Before you begin”, backup or rename copies of version 8.1 JCLLIB/PARMLIB datasets.
  - c. Set the value of the **SYS** parameter to the same system that is defined for your existing version 8.1 Repository database.
  - d. Set the value of the **DB** parameter to the same value that is defined for your existing version 8.1 Repository database.
  - e. Set the value of the **DBGKB** parameter to the same value that is defined for your existing version 8.1 Global Knowledge Base (GKB) database.



**Note:** If you have multiple repositories sharing the same GKB database, you must use a different **DBGKB** name to create a new version 8.2 GKB database. See [Migration planning and consideration on page 47](#), [step 6 on page 48](#) .

- f. Set the value of the **REPZSCHM** parameter to the same value that is defined for your version 8.1 Repository database.
- g. Set the value of the **GKBZSCHM** parameter to the same value that is defined for your version 8.1 GKB database.



**Note:** If you have multiple repositories sharing the same GKB database, you must use a different **GKBZSCHM** name to create a new version 8.2 GKB database. See [Migration planning and consideration on page 47](#), [step 6 on page 48](#) .

- h. Set values of the remaining Db2 parameters (e.g. DBSSID, LOC) to the same values that are defined for your version 8.1 Repository database.
  - i. The default value for the **BPIX** parameter is set to BP8K0 and must be activated before usage. Compressed indexes require Bufferpools to be defined with BP8K0-BP8K9, BP16K0-BP16K9, or BP32K-BP32K9. It cannot be BP0-BP49.
2. Submit the HSISCUST job. DO NOT share members of JCLLIB/PARMLIB between V8.1 and V8.2. Some member names may be the same, but the contents differ.
  3. Edit and update jobs in the JCLLIB library and parameters in the PARMLIB library if there are special site requirements.
  4. Run the following migration jobs:

- a. HSISWS01 - Submit the job to verify whether all database changes have been applied. The comments section in the job describes a list of version 8.1 PTFs where database changes for the Repository must be applied. Also, this job verifies whether there are records in the TUSEMTD table with column FHWDID having values of 0 (zero).

**DO NOT** proceed to the next job, HSISWS02, until all database changes for version 8.1 have been applied. OA56618/UJ00637 is the last PTF from version 8.1 where database changes need to be applied. This PTF requires significant effort in implementation due to changes in the largest table - TUSEMTD.

To fix records in the TUSEMTD table with column FHWDID having values of 0 (zero), refer to 'Additional instructions' in the technote at this web address: <https://www.ibm.com/support/pages/hold-act-ptf-uj00637>

**A condition code of 0 is expected.**

- b. HSISWS02 - Submit the job to display the meta data of the version 8.1 Repository, LKB and LKU objects. Verify that the number of version 8.1 Db2 objects match the expected result. If the expected result does not match, DO NOT proceed to the next job, HSISWS03. Investigate why there are differences. Possible reasons are

described in the comments section of the job. Upon successful completion of the job, proceed to the next job, HSISWS03.

**A condition code of 0 is expected.**

- c. HSISWS03 – Submit the job to alter table spaces (table spaces defined with single tables) to UTS, table spaces and indexes defined with 'COMPRESS YES'. Upon successful completion of the job, proceed to the next job, HSISWS04.

**A condition code of 0 is expected.**

- d. HSISWS04 – Submit the job to reorg the 3 largest table spaces - TUSEMTD, TMODULE and PRODUCT\_USE\_DETAIL, so as to instantiate these table spaces to UTS. Upon successful completion of the job, proceed to the next job, HSISWS05.

**A condition code of 4 is expected.**

- e. HSISWS05 – Submit the job to reorg the remaining 20 table spaces, so as to instantiate these table spaces to UTS. Upon successful completion of the job, proceed to the next job, HSISWS06.

**A condition code of 4 is expected.**

- f. HSISWS06 – Submit the job to drop primary keys and indexes of version 8.1 tables that were defined under shared segmented table spaces. Upon successful completion of the job, proceed to the next job, HSISWS07.

**A condition code of 0 is expected.**

- g. HSISWS07 – Submit the job to create 15 new UTS, new tables with names suffixed with \_V82, and indexes. These 15 tables in version 8.1 share 3 segmented table spaces. Upon successful completion of the job, proceed to the next job, HSISWS08.

**A condition code of 0 is expected.**

- h. HSISWS08 – Submit the job to copy data from 15 tables of version 8.1 to the newly defined tables suffixed with \_V82 from step (g). Upon successful completion of the job, proceed to the next job, HSISWS09.

**A condition code of 0 is expected.**

- i. HSISWS09 – Submit the job to drop version 8.1 segmented table spaces (shared by 15 tables), a deprecated table space, and rename tables suffixed with \_V82 to their original names. Once this job is run where the version 8.1 table spaces are dropped, there is no fall back to the 15 V8.1 tables. Upon successful completion of the job, proceed to the next job, HSISWS10.

**A condition code of 0 is expected.**

- j. HSISWS10 – Submit the job to drop LKB indexes, creates new LKB/LKU UTS, new tables with names suffixed with \_V82, and indexes. Upon successful completion of the job, proceed to the next job, HSISWS11.

**A condition code of 0 is expected.**

- k. HSISWS11 – Submit the job to copy LKB/LKU data of version 8.1 to the newly defined tables from step (j). Upon successful completion of the job, proceed to the next job, HSISWS12.

**A condition code of 0 is expected.**

- l. HSIWS12 – Submit the job to drop version 8.1 LKB/LKU segmented table spaces and rename tables suffixed with \_V82 to their original names. Once this job is run where the version 8.1 LKB/LKU table spaces are dropped, there is no fall back to V8.1 LKB/LKU data. Upon successful completion of the job, proceed to the next job, HSIWS15.

**A condition code of 0 is expected.**

- m. HSIWS15 – At this point, all Repository and LKB/LKU objects, and data have been migrated to V8.2. Submit the job to update the Repository database, define new Db2 objects, add new columns and modify existing columns. These are required for new functions in version 8.2. Upon successful completion of the job, proceed to the next job, HSIWS16.

**A condition code of 0 is expected.**

- n. HSIWS16 – Submit the job to populate data to the version 8.2 Repository database. Upon successful completion of the job, proceed to the next job, HSIWS02.

**A condition code of 0 is expected.**

- o. HSIWS02 - Submit the job to display the meta data of the newly migrated version 8.2 Repository, LKB and LKU objects. Verify that the number of version 8.2 Db2 objects match the expected result.

**A condition code of 0 is expected.**

5. Backup version 8.2.

- a. HSIUT01 – run the version 8.2 job to backup all 46 Repository UTS
- b. HSIUT04 – Submit this job to run RUNSTATS for the version 8.2 repository

6. HSIADB02 – Submit the job to drop and create a new GKB database and its dependent objects.

- If you are creating a new version 8.2 GKB database with different GKBDB/GKBZSCHM names, just submit the job. This creates a new version 8.2 GKB database and its dependent objects.

Use this approach if you have multiple version 8.1 repositories sharing the same version 8.1 GKB database. See [Migration planning and consideration on page 47](#), [step 6 on page 48](#).

- If you are creating the version 8.2 GKB database where the GKBDB/GKBZSCHM have identical names to version 8.1, then uncomment step `//*DROPGKB`. This will drop the version 8.1 GKB database and create a new version 8.2 GKB database with the same GKBDB/GKBZSCHM names as version 8.1.

Version 8.2 GKB has new tables, new columns, and columns with expanded column sizes.

- Upon successful completion of the job, proceed to the next job.

**A condition code of 0 is expected.**

7. HSIHGKBL – Submit the job to populate the newly created version 8.2 GKB database.

A GKB level is shipped with this migration. To download the latest GKB level, refer to topic [Updating the Global Knowledge Base on page 61](#) .



**Note:** Using a version 8.1 GKB level is not supported, as the table layouts are different.

**A condition code of 0 is expected.**

8. HSI\_SGRTB – Optional. Submit the job to grant privileges to users that require SELECT access to newly created version 8.2 tables.
9. Recovery – It is only possible to run the version 8.1 recovery job, HSI\_SUT02 (or equivalent in-house job), for failures in jobs HSI\_SWS04 and HSI\_SWS05.

## What to do next

After migration, use the following approach to manage the implementation to the new version:

1. You must apply the latest GKB update. This will ensure that all product identifications are up to date when you run the Inquisitor Import job, HSI\_SIQIM. For each repository, run HSI\_SIQIM for **all** LPARs before you run any Usage Import job, HSI\_SUIMP. You can continue to use existing version 8.1 Inquisitor fully-scanned files as inputs for the version 8.2 HSI\_SIQIM Inquisitor Import job.
2. For each repository, run the HSI\_SIQIM job for every LPAR with setting of FULLREMATCH=Y. For performance reasons, exclude the Aggregator job step, except for the last HSI\_SIQIM job. Please read the comments in the "Performance consideration" section of job HSI\_SIQIM job before you proceed.
3. For the last HSI\_SIQIM job, update the Aggregator jobstep with COUNTUSAGEFULL=Y. For example:

```
//AGGR EXEC HSIJSQLE,PROG=HSICTLAG,TPARAM=HSISAGP1
//USERPARM DD *
COUNTUSAGEFULL=Y
```

Run the last HSI\_SIQIM job with COUNTUSAGEFULL=Y for the Aggregator job step.

4. After running the last HSI\_SIQIM job, in the Aggregator jobstep, set COUNTUSAGEFULL=N (the default setting).
5. Repeat steps 1 to 4 for the next repository.
6. Before you run any Usage Import job, HSI\_SUIMP, you must run the Inquisitor Import job, HSI\_SIQIM, for **all** LPARS (as described in step 1). Failure to complete running the Inquisitor Import job ( HSI\_SIQIM) for all LPARs before you start running Usage Import (HSI\_SUIMP) could result in errors during the Aggregator job step. This is because product identifications may not be up to date.

For each repository, run the HSI\_SUIMP job for every LPAR. For performance reasons, exclude the Aggregator job step, except for the last HSI\_SUIMP job. Please read the comments in the "Performance consideration" section of job HSI\_SUIMP job before you proceed.

- a. For the last HSI\_SUIMP job, update the Aggregator jobstep with COUNTUSAGEFULL=Y. For example:

```
//AGGR EXEC HSIJSQLE,PROG=HSICTLAG,TPARAM=HSISAGP1
//USERPARM DD *
COUNTUSAGEFULL=Y
```

Run the last HSI\_SUIMP job with COUNTUSAGEFULL=Y for the Aggregator job step.

- b. After running the last HSISUIMP job, in the Aggregator jobstep, set COUNTUSAGEFULL=N (the default setting).
  - c. Repeat steps 6 to 6b for the next repository.
7. Configure APF authorization for the version 8.2 hsi.SHSIMOD1 load library.
8. When the version 8.2 Inquisitor scans and Usage Monitors are ready for use, you can run 8.2 operational jobs and discontinue version 8.1 tasks.
- a. Review the settings in the Inquisitor scan jobs, before submissions:

HSISINQU – PLX=N,PACK=0 (default)

HSISINQZ – PACK=0 (default)

- b. Before starting HSISUMON, review parameters:

PARMLIB member HSISMNPM – different parameters and default values.



**Note:** Usage Monitor job HSISUMON requires z/OS version 2.3, or later.

- c. HSISZCAT – different parameters and default values:

Parameters 'JNM=Y,UID=Y,JAC=Y' are now the default.

- d. HSISIQIM – parameter COUNTUSAGE = N is now the default.
- e. HSISUIMP – parameter COUNTUSAGE = N is now the default.

## Migrating from version 8.1 to Version 8.2 1.1 (SQLite database)

When you upgrade to IBM Z Software Asset Management version 8.2 for SQLite database, there is some porting of data within the Repository database. New SQLite objects are defined and obsolete objects dropped from the Repository. The existing version 8.1 GKB database is dropped and re-created with the same database name for version 8.2.

### Before you begin

Make a backup of your version 8.1 Repository database by running job HSISUT01 from your version 8.1 JCLLIB.

Make a backup or rename your JCLLIB and PARMLIB data sets. Version 8.2 will use the same dataset names for JCLLIB and PARMLIB.

#### Migration planning and consideration:

1. If your existing version 8.1 Repository database (including LKB/LKU) and GKB use different schema names, then you need to modify the migration jobs to suit your site requirements.
2. The version 8.2 Usage Monitor job/started task (HSISUMON/HSIJMON) requires a minimum level of z/OS V2.3 or later. It will fail if run in z/OS V2.2 or earlier.
3. Each SQLite repository with its own GKB and also its own hsi.SHSMOD1 load library should be migrated to version 8.2 all at the same time. A version 8.2 hsi.SHSIMOD1 load library cannot be used by a version 8.1 repository.
4. Housekeeping:

Perform housekeeping on the version 8.1 Repository database before you start your migration process. This should reduce the time required to migrate all the data.

- a. **HSISLDEL** - If you have any obsolete LPARs in the repository, you should delete the obsolete LPARs by running job HSISLDEL.
- b. **HSISPDEL** - TMODULE is one of the biggest tables and it contains modules of which a huge percentage are in-house programs. To delete obsolete modules (especially in-house programs), refer to job HSISPDEL. You need to define a date range for deletion and a sample SQL statement is provided in the job to list date ranges. HSISPDEL deletes modules based on any load libraries that have been marked deleted.
- c. **HSISUDEL** - TUSEMTD is the largest table. Performing housekeeping on this table should be part of best practices.

To determine the status of this table, run the following SQL statement:

```
SELECT FPERIOD, COUNT(*) FROM &RESPZSCHM.TUSEMTD
GROUP BY FPERIOD ;
```

Next, in the Usage Deletion job HSISUDEL, select the date range for deletion. Follow the instructions in the job – if you have never deleted before, you should delete Usage records in increments. Do it for all LPARs. Run the SQL statement again to check the number of outstanding records in TUSEMTD.

A good guideline on the number of records to be retained is to run HSISUDEL monthly for all LPARs with a fixed set of parameter settings:

```
KEEPDETAIL=3 (or 6)
```

```
KEEPAGGR=12
```

This will retain detailed Usage records for the current month and the previous 3 (or 6) months, and summarized records for the current month and the previous 12 months.

5. Continue to run your version 8.1 Usage Monitor job/started task (HSISUMON/HSIJMON), but stop the Analyzer and do not run any version 8.1 operational jobs during the migration.

## About this task

Perform these migration tasks for every SQLite Repository in your IBM Z Software Asset Management environment.

## Procedure

1. In IBM Z Software Asset Management version 8.2, make a copy of the HSISCUST member in the hsi.SHSISAMP data set and modify the following parameters:
  - a. Set the value of the new **DBTYPE** parameter to SQLITE.
  - b. Set **HSIINST** to the same value to the one defined for the existing 8.1 system. As stated in the section, “Before you begin”, it is imperative that you either backup or rename copies of version 8.1 JCLLIB/PARMLIB data sets.
  - c. Set the value of the **SYS** parameter to the same system that is defined for your existing version 8.1 Repository database.

- d. Set the value of the **REPZSCHM** parameter to the same value that is defined for your version 8.1 Repository database.
  - e. Set the value of the new **GKBZSCHM** parameter to the same value that is defined for your version 8.1 GKB database.
  - f. Set the value of the **SQLTZFS** parameter to the same value that is defined for your version 8.1 zFS linear VSAM data set.
  - g. Set the value of the **SQLTPATH** parameter to same value that is defined for your version 8.1 path of the USS directory.
2. Submit the HSISCUST job. The JCLLIB/PARMLIB datasets created use the same names as created in version 8.1. The same dataset names for JCLLIB/PARMLIB must be used in version 8.2 because of the relationships between the high level qualifier HSIINST parameter and the SQLTZFS/SQLTPATH parameters.
    - a. SQLTZFS = '&HSIINST.&SYS..ZFS'
    - b. SQLTPATH = '/u/tadz/&SQLTZFS'
  3. Edit and update jobs in the JCLLIB library and parameters in the PARMLIB library if there are special site requirements.
  4. Run the following migration jobs:

- a. HSISWS01 - Submit the job to verify whether all database changes have been applied. The comments section in the job describes a list of version 8.1 PTFs where database changes for the Repository must be applied. Also this job verifies whether there are records in the TUSEMTD table with column FHWD having values of 0 (zero).

**DO NOT** proceed to the next job, HSISWS02, until all database changes for version 8.1 have been applied. OA56618/UJ00637 is the last PTF from version 8.1 where database changes need to be applied. This PTF requires significant effort in implementation due to changes in the largest table, TUSEMTD.

To fix records in the TUSEMTD table with column FHWD having values of 0 (zero), refer to 'Additional instructions' in the technote at this web address: <https://www.ibm.com/support/pages/hold-act-ptf-uj00637>

**A condition code of 0 is expected.**

- b. HSISWS02 - Submit the job to display the meta data of the version 8.1 Repository, LKB and LKU objects. Verify that the number of version 8.1 SQLite objects match the expected result. If the expected result does not match, DO NOT proceed to the next job, HSISWS13. Investigate why there are differences. Possible reasons are described in the comments section of the job. Upon successful completion of the job, proceed to the next job, HSISWS13.
- c. HSISWS13 – Submit the job to rename version 8.1 tables to names suffixed with \_OLD, create new tables, and copy data from the renamed tables to the newly created tables. Upon successful completion of the job, proceed to the next job, HSISWS14.
 

**A condition code of 0 is expected.**
- d. HSISWS14 – Submit the job to drop obsolete version 8.1 tables. Upon successful completion of the job, proceed to the next job, HSISWS15.

**A condition code of 0 is expected.**

- e. HSISWS15 – At this point, all Repository and LKB/LKU objects, and data have been migrated to V8.2.

Submit the job to update the Repository database, define new Db2 objects, add new columns and modify existing columns. These are required for new functions in version 8.2. Upon successful completion of the job, proceed to the next job, HSISWS16.

**A condition code of 0 is expected.**

- f. HSISWS16 – Submit the job to populate data to the version 8.2 Repository database. Upon successful completion of the job, proceed to the next job, HSISWS02.

**A condition code of 0 is expected.**

- g. HSISWS02 - Submit the job to display the meta data of the newly migrated version 8.2 Repository, LKB and LKU objects. Verify that the number of version 8.2 objects match the expected result.

**A condition code of 0 is expected.**

5. HSISDB02 – Submit the job to drop and create a new GKB database and its dependent objects. Before submitting this job, uncomment step `//*DROPGKB`. This will drop the version 8.1 GKB database and create a new version 8.2 GKB database. Version 8.2 GKB has new tables, new columns and columns with expanded column sizes. Upon successful completion of the job, proceed to the next job.

**A condition code of 0 is expected.**

6. HSISGKBL – Submit the job to populate the newly created version 8.2 GKB database. A GKB level is shipped with this migration. To download the latest GKB level, refer to topic [Updating the Global Knowledge Base on page 61](#).



**Note:** Using a version 8.1 GKB level is not supported, as the table layouts are different.

**A condition code of 0 is expected.**

7. Backup version 8.2.

HSISUT01 – run the version 8.2 job to backup the SQLite database.

8. Recovery – If failures occur during the migration, and a recovery is required, run the version 8.1 job, HSISUT02 to recover using the backup copy created just before the start of migration.

## What to do next

See section ["What to do next" on page 53](#) in topic [Migrating from version 8.1 to Version 8.2 1.1 \(Db2 database\) on page 47](#).

## Post migration errors

If migration from version 8.1 to version 8.2 is incomplete, or if a wrong combination of files, jobs, or PARMLIB members are used between the two versions, then you might get the following errors:

### 1. Running V8.2 HSIQIM (IQ Import) with V8.1 GKB

```
SQL for FAILED SQLPrepare:
SELECT "FMODCNT","FPOVID","FPPNUMNAME","FPRODUCTID","FVERSIONNAME","FFMID","FSUITE_ID" FROM
&GKBZSCHM_GKB7.TVERSION WHERE FPOVID = ?
ERROR -- RC = -1 Reported from //"HSI910S.COMMIT.C(CLIRS)", line 262 -----
SQLSTATE: S0022 Native Error Code: -206
DB2 FOR OS/390}{ODBC DRIVER}{DSN12015} DSNT408I SQLCODE = -206,
ERROR: FSUITE_ID IS NOT VALID IN THE CONTEXT WHERE IT IS USED
```

#### Reason:

New tables and columns have been defined in version 8.2 GKB.

#### Solution:

- a. HSI8DB02 - run this job to drop the version 8.1 GKB and create a new version 8.2 GKB.
- b. HSI8GKBL - run this job to populate the version 8.2 GKB database.

### 2. Running V8.1 HSIQIM (IQ Import) with V8.2 GKB

```
=ERROR= SELECT
"FPRODUCTID","FPRODUCTNAME","FOPTIONNAME","FVENDORID",
"FCATEGORY","FDESCRIPTION","FPRODSTATUS" FROM
TFREPZ8.TPRODUCT
WHERE FPRODUCTNAME = ? AND FOPTIONNAME = ?
m_hstmt=17 IsOpen()=0 m_rc=-1 autocommit=0
ERROR -- RC = -1 Reported from //"HSI810S.FMPROM.C(CLIRS)", line 385
-----
SQLSTATE: 22001
Native Error Code: -302
{DB2 FOR OS/390}{ODBC DRIVER}{DSN12010}
DSNT408I SQLCODE = -302,
ERROR: THE VALUE OF INPUT VARIABLE OR PARAMETER
NUMBER 1 IS INVALID OR TOO LARGE FOR THE TARGET COLUMN
OR THE TARGET VALUE
```

#### Reason:

Version 8.2 GKB columns defined with expanded sizes contain data that are too large to be processed by the version 8.1 code.

#### Solution

Version 8.1 repository must use a version 8.1 GKB.

### 3. Running V8.1 HSIQIM (IQ Import) with V8.2 IQ scanned file

```
Abort: UNZIP(DD:INQDATA ) failed on open. HSISHRNK rc=12
** 00008 IS UNSUPPORTED COMPRESSION METHOD
Error occurred in opening: DDNAME INQDATA to do iqimport
Error during Importer initialization
Number of explicit commits = 0
HSIC020E Inquisitor Import encountered errors. Error code = 6209
Elapsed time: 0 days 0 Hrs, 00 Mins, 00 Secs
HSIC023E Inquisitor Import error occurred in opening: DDNAME INQDATA
HSIC020E Inquisitor Import encountered errors. Error code = 6209
```

**Reason:**

New compression routine in version 8.2 is not supported in version 8.1.

**Solution:**

Version 8.1 IQ Import must use version 8.1 IQ scanned files.

**4. Running V8.1 HSISUIMP (Usage Import) with V8.2 Usage files**

```
Abort: UNZIP(DD:UIMPDATA) failed on open. HSISHRNK rc=12
** 00008 IS UNSUPPORTED COMPRESSION METHOD
Error occurred in opening input file.
Number of times uzstream::getline() called = 0(Pass 1)
Usage Import file Pass1 check return code = 6016
```

**Reason:**

New compression routine in version 8.2 is not supported in version 8.1.

**Solution:**

Version 8.1 Usage Import must use version 8.1 Usage files.

## Migrating repositories between different databases (optional)

If you wish to port repositories from the Db2 database to the SQLite database, or vice versa, follow the instructions in this section. Note that data from the LKB/LKU tables are not ported across as part of this process.

### Before you begin

Refer to [Installing and customizing IBM Z Software Asset Management on page 21](#) for how to define new repositories. To migrate repositories between the two databases, follow the steps here:

## Migrating version 8.1 (Db2 database) to version 8.2 (SQLite database)

### Procedure

1. Unload data from version 8.1 (Db2 database). Use member HSISUN81 in JCLLIB.
2. Define a new SQLite database in version 8.1.
3. Load data into the newly created SQLite database with input from step 1. Use member HSISLO81 in JCLLIB.
4. Migrate the version 8.1 SQLite database to version 8.2.

For instructions on the migration process, refer to [Migrating from Version 8.1 to Version 8.2 \(SQLite database\) on page 59](#).



**Note:** It is much easier to migrate SQLite from version 8.1 to version 8.2 (fewer migration steps) after data has been ported.

5. After successful migration, refer to instructions in [What to do next on page 53](#)

## Migrating version 8.1 (SQLite database) to version 8.2 (Db2 database)

### Procedure

1. Migrate version 8.1 to version 8.2 (SQLite database).

For instructions on the migration process, refer to [Migrating from Version 8.1 to Version 8.2 \(SQLite database\)](#) on [page 59](#).



**Note:** It is much easier to migrate SQLite from version 8.1 to version 8.2 (fewer migration steps) after data has been ported.

2. Unload data from version 8.2 (SQLite database). Use member HSISUN82 in JCLLIB.
3. Define a new Db2 Repository database in version 8.2.
4. Load data into the newly created Db2 Repository database with input from step 2. Use member HSISLO82 in JCLLIB.
5. After successful migration, refer to instructions in [What to do next on page 53](#).

# Chapter 6. Collecting and importing data with IBM Z Software Asset Management

IBM Z Software Asset Management includes programs that collect system and usage data, import, filter, and match this data, update the Repository tables, and make the data available for review and query.

## Updating the Global Knowledge Base

IBM provides monthly updates to the Global Knowledge Base (GKB) so that you can keep your product inventory definitions up-to-date. You can also submit items to IBM® support for inclusion in GKB updates.

### About this task

Updates to the GKB are available from the [ShopzSeries website](#) and you can register for notifications when updates are posted

### Procedure

1. Go to the ShopzSeries site and order the latest GKB PTF.
2. Use SMP/E to install the PTF. Follow the instructions specified in HOLD ACTION, if any.
3. In the GKB load job, HSISGKBL, update the SET INDSN= value with the name of the library updated by SMP/E, and then submit the job.

## Collecting scanned libraries with the Inquisitor for z/OS

The Inquisitor is a program that scans and collects information about partitioned data set (PDS) and partitioned data set extended (PDSE) program libraries. The Inquisitor Import program takes the collected data as input to form the basis of your software inventory.

### About this task

The Inquisitor Import reads data from Inquisitor scans, where the data is filtered and matched to products. The filtered, matched data is then copied to the Repository tables where it can be viewed and queried by the Analyzer reporting utility. For related information,

---

Related information

[Importing Inquisitor data on page 120](#)

[Importing Inquisitor data on page 120](#)

## Running the Inquisitor program

The HISISINQZ job in the JCLLIB library performs the Inquisitor collection. This job is generated from the HSISCUST post-installation customization job.

### About this task

The length of time it takes this job to run depends on the number of volumes and libraries to be scanned. Run this job during off-peak periods.

### Procedure

1. In the HISISINQZ job, check the values for the following parameters and change if necessary:
  - The **ALLMSG** parameter requests both **DSNMSG** and **PGMMSG** message logging.
  - The **PLX** parameter is set to **N** (no). Run with this setting on all systems even if you later plan to use **PLX=Y** for future scheduled scans. Review information about the **PLX** parameter before you use **PLX=Y**.
  - The **PACK** parameter is set to 1 to request that zipped output is written using the fastest level of the **deflate** algorithm. Higher values up to 9 can be used for better compression, but they will use more CPU time. Specify **PACK=0** if use of the **shrink** zip algorithm is required.
  - The **LLQ** parameter is set to **Z&SMF**. You can change this value if you want to generate data sets with unique names without changing the JCL library.

These values are set when the HISISINQZ job is created.

2. In the program parameter string, you can specify a report message level and an override to the system identifier. Use commas to separate the various settings specified within the program parameter string.
3. Run the HISISINQZ job.

### PLX parameter of the Inquisitor program

The **PLX** parameter can reduce the time it takes to scan and process different systems that have completely shared DASD, and therefore identical software inventories. When you set **PLX=Y**, the Inquisitor Import detects libraries that are mirrors or libraries that have not changed and quickly processes scans of these shared SIDs.

Plan your Repository to receive scans of system identifiers (SIDs) containing libraries that are unique in library name and volume, except when identically-named libraries are copies or are shared. If you have libraries that are identical in library name and volume name but are intended to have different content, place these libraries in different Repositories so that they can be processed separately.

If a library with the same library name and volume name is encountered in different SID scans, the Inquisitor Import considers the first instance that it encounters on the first SID to be the base. The Inquisitor Import treats any subsequent instances on different SIDs as mirrors.

The locations of all SIDs for a given library are recorded, but module discovery information is only calculated and stored when the library is encountered on its base SID. This approach ensures consistency in matching if the copies are not synchronized. The approach also saves processing time when SIDs are identical. If the Inquisitor Import encounters mirror libraries, it displays their names, current SIDs, and base SIDs in the log file, and reports their number at the end of the run.

If an SID is decommissioned and is no longer available for scanning, you can run the system deletion job to remove the SID and any libraries, modules, and products that are exclusively attached to the deleted SID. For shared libraries, only the record of the library that is attached to the specified SID is removed. The contents of the library are then attached to the subsequent SID in the list which then functions as the base SID.

If the **PLX=Y** option is specified during the Inquisitor run, the Inquisitor Import applies the results of the scan from the Inquisitor file to all SIDs that were previously processed and share the same sysplex ID with the SID in the Inquisitor file. An existing library is processed on its base SID but is recorded as seen on all SIDs of the sysplex. A new library is processed on the current SID which becomes its base SID and is recorded as seen on all SIDs of the sysplex.

The Inquisitor Import requires that the Inquisitor file is more recent than any Inquisitor file that it previously processed for the same SID. If you specify the **PLX=Y** option during the Inquisitor scan, the Inquisitor file must be more recent than previously processed files of all SIDs of the sysplex.

The default value for the **PLX** parameter is **N** (no). If you intend to use the **PLX=Y** option to save scanning time, you must scan all SIDs at least once and present all the scans to the Inquisitor Import, so that it can determine how the different SIDs are shared.

When you specify the **PLX=Y** option, the Inquisitor Import processes the file in the following manner:

- Treats the content of all SIDs that share the sysplex ID with the currently-scanned SID as being identical to each other.
- Applies the scan results to all SIDs of the sysplex.

Because the Inquisitor Import process does not verify that all SIDs are identical, incorrect results can occur if the SIDs of the sysplex have different content. Use the **PLX=Y** option only if you are sure that all SIDs of the sysplex are identical in content at the time of the scan.

## Inquisitor program parameters and files

The Inquisitor program has mandatory and optional parameters that affect how data is collected. The program uses some mandatory files as well as some optional files.

**Table 8. Parameter settings for the Inquisitor**

Parameter	Description
DSNMSG	Requests that messages relating to processed data sets, which might otherwise be suppressed, are to be logged in the SYSPRINT report.
PGMMMSG	Requests that messages relating to processed programs, which might otherwise be suppressed, are to be logged in the SYSPRINT report.
ALLMSG	Requests both DSNMSG and PGMMMSG message logging.
NOVSR	Specifies that volume statistics reports normally generated from VTOC-scanning requests are not to be written.

**Table 8. Parameter settings for the Inquisitor (continued)**

Parameter	Description
NOEAR	Specifies that the execution activity report normally present at the end of the SYSPRINT output is not to be written.
NOREP	Specifies both NOVSR and NOEAR in a single keyword.
NOAPF	Specifies that the Inquisitor is to run in an environment which is not APF authorized.
NOHOST	Requests that the call to HSIPHOST to collect the TCPIP host name and IP address is bypassed.
OLDTAG	Specifies that tag data members created by program HSITAGP will not be ignored, but should be processed so that the tag data can be imported into the LKB.
SID=	The value is up to 4 characters long, and specifies the system identifier to be contained in the data output from the Inquisitor. If the SID identifier override is omitted, the system SMF identifier is used. The SID parameter setting is used when the SMF system identifier of a system is not unique. For example: SID=SYS2
PLX=	The parameter is used to identify if the Inquisitor data being collected is part of a SYSPLEX with fully shared DASD. The value is either Y or N.  If the PLX parameter is not used, the default value of N is created in the Inquisitor header record.
PLEXNAME=	The value is up to 8 characters long, and specifies the sysplex identifier to be contained in the data output from the Inquisitor. If the PLEXNAME identifier override is omitted, the actual sysplex name is used. The primary purpose of the PLEXNAME parameter is to provide a means for controlling the scope of sysplex-wide inventory updates.
PACK=	The value is a single decimal digit (0-9) and specifies the level of compaction that will be used to write zipped output. The value of 0 specifies that <i>shrink</i> will be used. Values in the 1 to 9 range specify the compaction level of <i>deflate</i> to be used. PACK=1 is the program default.
LLQ=	This parameter is used to specify a suffix string made up of one or more data set name qualifiers to be appended to the data set name of the HSIPZIP and HSIPOUT data set. Its maximum length is 44 characters. It may contain both static and dynamic system symbols, and the user symbols &SMF. (SMF system identifier) and &SYSLPAR. (LPAR name) supplied by the Inquisitor. Use the LLQ setting when you need to create uniquely named data sets without changing the JCL.

**Table 9. Files used by the Inquisitor**

Filename	Description
SYSPRINT	A mandatory report file.
TAGREP	An optional report file that summarizes tag data collected by the Inquisitor.

**Table 9. Files used by the Inquisitor (continued)**

Filename	Description
SYSIN	A mandatory request input file. It processes fixed length, variable length, and undefined record formats. Records shorter than 72 bytes will be logically extended by the Inquisitor with blanks.
HSIPZIP	An optional output file that contains compressed Inquisitor data. It is written using a variable length record format. You must provide DCB information to ensure optimal use of DASD space. In the case where HSIPOUT is not allocated and HSIPZIP processing encounters an S213-C8 abend, the Inquisitor will attempt to write uncompressed output to this file, overriding the LRECL as appropriate.
HSIPOUT	<p>An optional output file that contains uncompressed Inquisitor data. It is not specified in the packaged sample, as the use of HSIPZIP is preferred, due to its reduced space requirements. HSIPOUT also contains variable length records. The program supplies the appropriate LRECL. By default, system determined block size is used.</p> <p>If you want to direct the Inquisitor output to a compressible extended-format data set, then you should use the HSIPOUT file. The HSIPZIP file employs update-in-place processing, which prevents the use of DFSMS™ compression.</p>
MCDS	An optional file that allocates the DFHSM MCDS data set, and is required if any requests contain the REMIGRATE or NOML2 operands. Further, if supplied for other requests, you can use it to avoid recalling data sets which are not load libraries. If the DFHSM MCDS is spread over more than one data set, use the DD names MCDS2, MCDS3, and MCDS4 consecutively. This allocates all the MCDS data sets in key range order.
ABRIN	An optional SYSIN file belonging to the FDRABRP utility program that is required if any requests contain the ABRMIG or ABRARC operands. It is primed by the Inquisitor during execution. For this reason, a single track VIO file is an ideal allocation.
ABRPRINT	An optional SYSPRINT file belonging to the FDRABRP utility program that is required if any requests contain the ABRMIG or ABRARC operands. It is an output-only file, and is not processed by the Inquisitor.
HSIDAMAP	An optional file containing logical volume mapping assignment statements.

## Inquisitor program command syntax

The Inquisitor program includes SYSIN commands and optional command operands.

### **SYSIN commands**

The Inquisitor program uses the SCANCMD, SCANDIR, and SCANPGM SYSIN commands that are described in the following table.

**Table 10. SYSIN commands used by the Inquisitor**

Command	Description
SCANCMD	<p>Allows command syntax and operand consistency to be checked by the Inquisitor without initiating an actual scan for program libraries. It performs a parse only operation, although output files are opened.</p> <p>Error messages relating to syntax and operand errors are produced as usual. This verb is useful if you are formulating the best request combination when implementing on any given system.</p>
SCANDIR	<p>Collects data from program library directory entries. Contents of program members are not accessed.</p> <p>Compared to SCANPGM, its reduced data collection allows it to run faster. Although all syntactically correct operands are allowed, some operands relating to data from member contents are ignored during processing. SCANDIR collects all of the information needed for automated software identification, and is the command of choice for a production environment.</p>
SCANPGM	<p>Collects all data collected by SCANDIR, and information from member contents. Such information relates to program structure and history.</p> <p>Use SCANPGM without FULLIDR if you want to collect PDS load module link edit dates and can tolerate the additional I/O and elapsed time of the scan.</p> <p>Use SCANPGM with FULLIDR to collect LE compiler details. This is not recommended for ongoing system-wide scans.</p> <p>IBM support might request SCANPGM output data to assist with problem diagnosis and resolution.</p>
SCANDEV	<p>Collects information about the input and output (I/O) configuration of the z/OS® system including online I/O devices, control units, and related channel path connectivity. The SCANDEV command has no operands.</p>

The Inquisitor can process multiple requests in a single program run. The output of these requests is contained in the same file.

This syntax diagram shows the SYSIN commands and their operands.

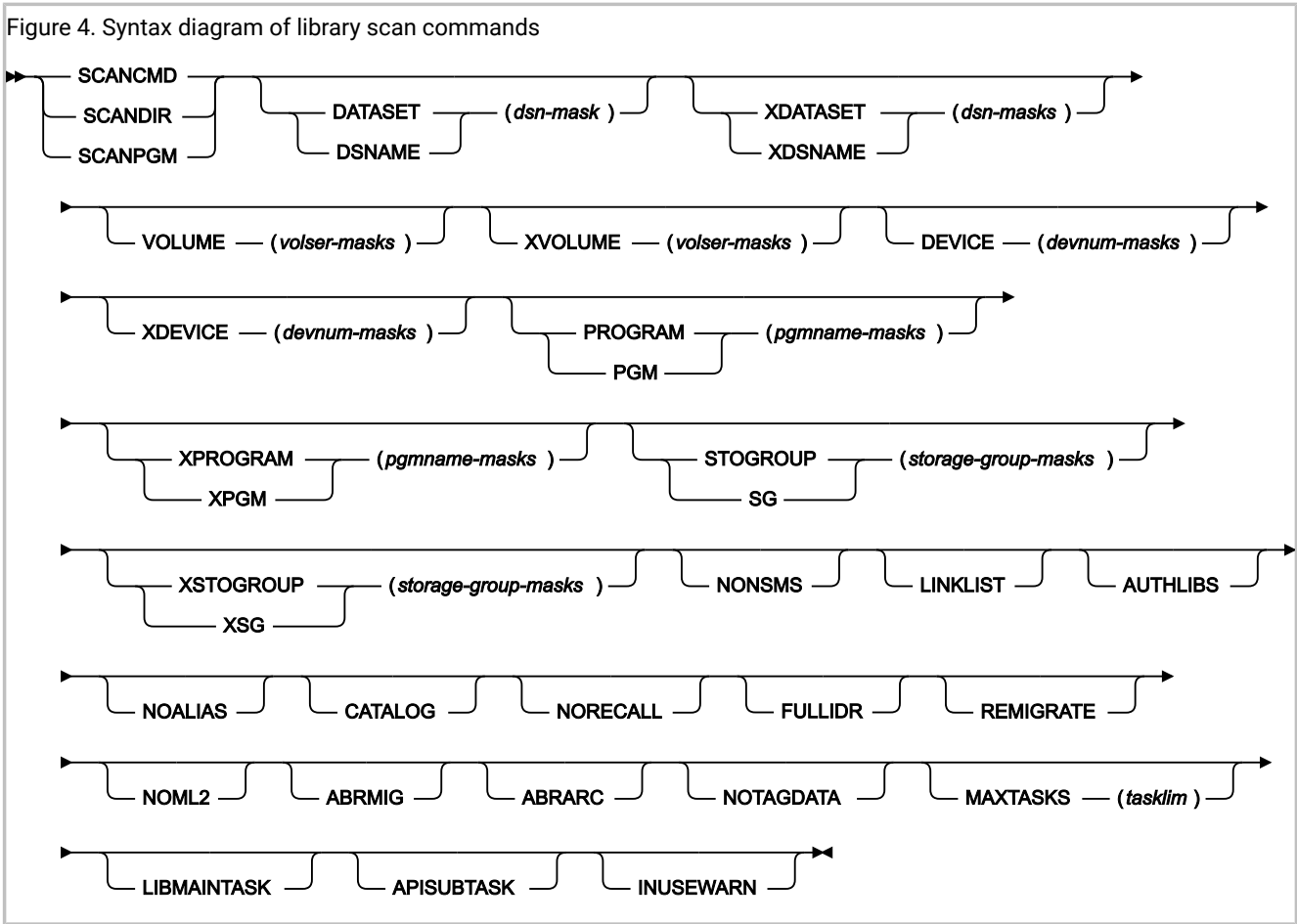

Operand defaults are:

```
DSNAME(*) VOLUME(*) DEVICE(*) PROGRAM(*)
```

All operands are optional. They are:

**DATASET Alias: DSNAME**

This operand specifies one or more 1 to 44 byte data set name masks. Only data sets with names matching any masks specified here are processed. Data sets with names not matching any masks specified here are not processed. Multiple masks must be separated by one or more delimiters. This operand can be specified more than once in a request, whereupon all masks specified in all occurrences of this operand are checked for selection matching. The precise treatment of asterisks in these masks is altered by the presence of the CATALOG keyword in the request. When CATALOG is specified, mask matching becomes qualifier aware and a single asterisk represents one, or part of, one qualifier only. When CATALOG is specified, use a double asterisk to specify any number of qualifiers. The data set name selection mask is the only mask affected by the CATALOG keyword. When the CATALOG keyword is present, exactly one DSNAME mask must be specified.

**XDATASET Alias: XDSNAME**

This operand specifies one or more 1 to 44 byte data set name masks. Data sets with names matching any mask specified here are not processed. Multiple masks must be separated by one or more delimiters. This

operand can be specified more than once in a request, whereupon all masks specified in all occurrences of this operand are checked for exclusion matching. If this operand is used, each mask must specify a subset of a DATASET mask.

### **VOLUME**

This operand specifies one or more 1 to 6 byte volume serial number masks. Only volumes with serial numbers matching any mask specified here are processed. Volumes with serial numbers not matching any mask specified here, are not processed. Multiple masks must be separated by one or more delimiters. This operand can be specified more than once in a request, whereupon all masks specified in all occurrences of this operand are checked for selection matching. A volume serial number mask of six asterisks specifies the current IPL volume, which is ascertained during execution.

### **XVOLUME**

This operand specifies one or more 1 to 6 byte volume serial number masks. Volumes with serial numbers matching any mask specified here are not processed. Multiple masks must be separated by one or more delimiters. This operand can be specified more than once in a request, whereupon all masks specified in all occurrences of this operand are checked for exclusion matching. If this operand is used, each mask must specify a subset of a VOLUME mask. A volume serial number mask of six asterisks specifies the current IPL volume, which is ascertained during execution.

### **DEVICE**

This operand specifies one or more 1 to 4 byte device number masks. Only volumes with device numbers matching any mask specified here are processed. Volumes with device numbers not matching any mask specified here, are not processed. Multiple masks must be separated by one or more delimiters. This operand can be specified more than once in a request, whereupon all masks specified in all occurrences of this operand are checked for selection matching. Standard character string mask matching is used. The use of characters which are not hexadecimal digits will not be detected by the program.

### **XDEVICE**

This operand specifies one or more 1 to 4 byte device number masks. Volumes with device numbers matching any mask specified here are not processed. Multiple masks must be separated by one or more delimiters. This operand can be specified more than once in a request, whereupon all masks specified in all occurrences of this operand are checked for exclusion matching. If this operand is used, each mask must specify a subset of a DEVICE mask. Standard character string mask matching is used. The use of characters which are not hexadecimal digits will not be detected by the program.

### **PROGRAM Alias: PGM**

This operand specifies one or more 1 to 8 byte program name masks. Only programs with names matching any mask specified here are processed. Programs with names not matching any mask specified here, are not processed. Multiple masks must be separated by one or more delimiters. This operand can be specified more than once in a request, whereupon all masks specified in all occurrences of this operand are checked for selection matching.

**XPROGRAM Alias: XPGM**

This operand specifies one or more 1 to 8 byte program name masks. Programs with names matching any mask specified here are not processed. Multiple masks must be separated by one or more delimiters. This operand can be specified more than once in a request, whereupon all masks specified in all occurrences of this operand are checked for exclusion matching. If this operand is used, each mask must specify a subset of a PROGRAM mask.

**STOGROUP Alias: SG**

This operand specifies one or more 1 to 8 byte storage group name masks. SMS-managed volumes in a storage group with a name matching any mask specified here are processed. SMS-managed volumes in a storage group with a name that does not match any mask specified here, are not processed. Multiple masks must be separated by one or more delimiters. This operand can be specified more than once in a request, whereupon all masks specified in all occurrences of this operand are checked for selection matching. Volumes which are not SMS-managed are not processed unless the NONSMS keyword operand is specified.

**XSTOGROUP Alias: XSG**

This operand specifies one or more 1 to 8 byte storage group name masks. SMS-managed volumes in a storage group with a name matching any mask specified here are not processed. Multiple masks must be separated by one or more delimiters. This operand can be specified more than once in a request, whereupon all masks specified in all occurrences of this operand are checked for exclusion matching. If both this mask and a STOGROUP mask are used, then each mask must specify a subset of a STOGROUP mask.

**NONSMS**

This keyword operand specifies that volumes which are not SMS-managed are eligible for processing. The presence of this operand means that SMS-managed volumes are not processed unless the STOGROUP operand was used to supply a storage group name mask.

**LINKLIST**

This keyword operand specifies that all link list data sets are to be unconditionally included for processing.

**AUTHLIBS**

This keyword operand specifies that all APF authorized data sets are to be unconditionally included for processing.

**NOALIAS**

This keyword operand specifies that any program member marked as an alias is to be excluded from processing.

**CATALOG**

This keyword operand specifies that data sets to be processed are located from a catalog search rather than VTOC searches. Data set alias names are not processed. The Inquisitor triggers and waits for a RECALL operation for each migrated data set which passes data set name mask processing, unless NORECALL is also specified.

**NORECALL**

This keyword specifies that migrated data sets are not to be recalled and are excluded from processing. This operand only has effect when the CATALOG operand is also specified. Data sets with a catalog entry indicating a volume serial number of MIGRAT, or ARCIVE, are deemed to be migrated.

**FULLIDR**

This keyword operand specifies that a full scan of CESD and IDR records is to be performed, even when a module would not have been selected for such processing. Depending upon the exact nature of the request being run, this operand can significantly elongate the elapsed time of Inquisitor runtime.

This operand is ignored for a SCANDIR request.

**REMIGRATE**

This keyword operand specifies that when a data set which had to be recalled has been processed, DFHSM is requested to migrate the data set again asynchronously. Migrated data sets can only be processed when the CATALOG operand is also specified. Only data sets with a catalog entry indicating a volume of MIGRAT are remigrated.

The presence of this operand requires that the MCDS file is allocated to the DFHSM MCDS. Access to the MCDS allows the Inquisitor to avoid recalls for data sets which are not partitioned, do not have an undefined record format, and do not have a block size of at least 1024.

**NOML2**

This keyword operand specifies that data sets migrated to level two are not to be recalled and are excluded from processing. Migrated data sets can only be processed when the CATALOG operand is also specified. Only data sets with a catalog entry indicating a volume of MIGRAT are checked for level two status.

The presence of this operand requires that the MCDS file is allocated to the DFHSM MCDS. Access to the MCDS allows the Inquisitor to avoid recalls for data sets which are not partitioned, do not have an undefined record format, and do not have a block size of at least 1024.

**ABRMIG**

This keyword operand indicates that when a catalog entry with a volume of MIGRAT is encountered, the FDRABR product is to be invoked to determine whether a recallable archived copy of the data sets is available or not. If it is, then the data set is processed. If not, then the data set is not processed.

The NORECALL operand takes precedence over this operand.

The effect of ABRMIG is not affected by the ABRARC operand.

The presence of this operand requires that the ABRIN and ABRPRINT files are allocated.

**ABRARC**

This keyword indicates that, when a cataloged data set cannot be found on the volume, the FDRABR product is to be invoked in order to determine whether a recallable archived copy of the data set is available. If it is, then the data set is processed. If not, the data set is not processed.

The NORECALL operand takes precedence over this operand.

The effect of ABRARC is not affected by the ABRMIG operand.

The presence of this operand requires that the ABRIN and ABRPRINT files are allocated.

**NOTAGDATA**

This keyword indicates that data written to program libraries by the Product Tagger is not to be collected and written to the Inquisitor output file. Use this operand only when you do not want to update the Local Knowledge Base during the import process with the latest Tagger data that could be found by the Inquisitor.

**MAXTASKS**

This operand specifies the maximum number of VTOC-scanning subtasks to be activated by the Inquisitor. These subtasks reduce the elapsed time of an Inquisitor scan by enabling the concurrent processing of multiple volumes. Reducing the number of subtasks reduces the demand on storage in the region and does not impact performance unless the main task has to wait longer for VTOC scan results. The operand value is a decimal number in the 1 to 200 range. The default value is 10. The actual number of subtasks used does not exceed the number of volumes to be scanned. Too high a value may impact critical applications due to I/O queuing. VTOC-scanning subtasks are not used for CATALOG requests.

**LIBMAINTASK**

This keyword specifies that all library scan processing is to be carried out by the main task. Without this operand being specified, VTOC-scanning subtasks may scan PDS (but not PDSE) libraries for SCANDIR (but not SCANPGM) requests, which has the benefit of further reducing the elapsed time of the scan. Data collected by subtasks is held in region storage until it is processed by the main task, and SCANDIR collects a much smaller volume of data than SCANPGM. The main task uses DESERV FUNC=GET\_ALL to read directories, whereas subtasks use QSAM which allows for efficient processing of corrupt PDS directories.

**APISUBTASK**

This keyword specifies that Program Binder API calls issued to process PDSE program objects during a SCANPGM FULLIDR request are to be performed by a subtask. Various conditions can cause Binder API calls to abend, and if such an abend occurs under the main task then Inquisitor processing is abnormally terminated. The main task can be insulated from such abends by attaching subtasks to perform the Binder API calls. Even if such subtasks abend, the main task can continue processing and should be able to complete a successful scan, provided that abending subtasks have not corrupted storage owned by the main task. Specifying this keyword will somewhat increase CPU overhead of a SCANPGM FULLIDR request, so its use is only recommended when it is known that such abends will be encountered and need to be tolerated.

**INUSEWARN**

This keyword specifies that failure to scan a data set because it was exclusively allocated to another job is to raise a warning condition instead of an error condition. When a data set scan attempt receives a DARC of hex 210, message HSIP092I is issued and the data set is queued for later retry. After the scan request is complete, queued data sets are reprocessed, and one of the messages HSIP093I (successful retry), HSIP094W (failed retry with INUSEWARN) or HSIP095E (failed retry without INUSEWARN) is issued, as appropriate.

**SYSDIN syntax rules for the Inquisitor**

Syntax rules are as follows:

- Only the first 72 bytes of an input record are ever scanned.
- Short records are extended to 72 bytes with blanks.
- Blanks and commas are equivalent.
- Subparameters of value operands are specified in parentheses.
- A continuation to the next record is requested by a plus or a hyphen when it follows a delimiter, or is at the start of a record.
- A continuation cannot be requested in the middle of a word or value.
- The part of the record following a continuation character is ignored and can be used for comments.
- Records beginning with an asterisk are comment records.
- Records containing only blanks or commas are comment records.
- Comment records are ignored by syntax parsing logic, and do not alter continuation status.
- TSO conventions apply to abbreviations. That is, operands can be abbreviated to the minimum unambiguous length. Verbs cannot be abbreviated.
- If the input record contains an ampersand, the system symbol substitution routine ASASYMBM is called to perform symbol substitution processing.
- All input requests are parsed and stored before the first request is processed.
- If a syntax error is encountered, no requests are processed. This is to reduce the instance of incorrect or unproductive requests triggering lengthy DASD subsystem scans. The error is in the last record echoed in SYSPRINT.
- Value masks are character strings which are compared to data found at run time. Comparison is performed one byte at a time, from left to right. For a match, the characters must compare equal, unless a generic mask character is found.
- System static symbols, system dynamic symbols, and &SMF (SMF system identifier) and &SYSLPAR (LPAR name), can be used to construct value masks. &SYSLPAR may resolve to a null string if z/OS® is running in a virtual machine.
- Valid generic mask characters are a percent (%), to flag a match for any single character, and an asterisk (\*), to flag a match for any character string segment of zero or greater length.

**Inquisitor examples**

These examples show some possible scenarios where you can customize the scope and type of processing when you run the Inquisitor program.

**Example 1**

These three statements are equivalent, and request data collection for all programs on all online DASD volumes.

```
SCANDIR
SCANDIR DA(*) PGM(*)
SCANDIR VOL(*) DS(*)
```

**Example 2**

To scan all SMS-managed volumes except volumes in storage group SGWORK use:

```
SCANDIR STOGROUP(*) XSTOGROUP(SGWORK)
```

**Example 3**

To scan all volumes except volumes in storage groups with names beginning with SGW use:

```
SCANDIR XSTOGROUP(SGW*) NONSMS
```

**Example 4**

To scan all volumes with serial numbers beginning with TSO and WRK, these two requests are used in a single program run:

```
SCANDIR VOLUME(TSO*)
SCANDIR VOLUME(WRK*)
```

Note that these 2 statements could be reduced to a single statement as follows:

```
SCANDIR VOLUME(TSO* WRK*)
```

**Example 5**

To scan all volumes except those with serial numbers beginning with TSO and WRK use:

```
SCANDIR XVOLUME(TSO* WRK*)
```

**Example 6**

To scan all volumes with serial numbers beginning with USR which are also in SMS storage groups with names beginning with SG for programs with names beginning with UTIL, use: .

```
SCANDIR VOLUME(USR*) STOGROUP(SG*) PROGRAM(UTIL*)
```

**Example 7**

To scan all data sets with high level qualifiers of SYS1, SYS2, SYS3, except z/OS® distribution libraries, use:

```
SCANDIR DSNAME(SYS%.**) XDSNAME(SYS1.A*)
```

**Example 8**

To restrict the data in the previous example to cataloged data sets, use:

```
SCANDIR DSNAME(SYS%.***) XDSNAME(SYS1.A*) CATALOG
```



**Note:** Note the extra asterisk in the data set name selection mask. Without this, only data set names with two qualifiers are selected. Data set name exclusion processing is not changed by the CATALOG operand.

### Example 9

To scan the current IPL volume, and any other linklist and APF authorized libraries use:

```
SCANDIR VOLUME(*****) LINKLIST AUTHLIBS
```

### Example 10

To scan the single cataloged data set SYS1.PPLIB without a lengthy DASD subsystem scan use:

```
SCANDIR DATASET(SYS1.PPLIB) CATALOG
```

### Example 11

To scan all cataloged SYS1 and SYS2 data sets use (a) two requests in a single program run, or (b) a single request. The two approaches exhibit similar resource consumption:

```
SCANDIR DA(SYS1.***) CAT
SCANDIR DA(SYS2.***) CAT

SCANDIR DS(SYS%.***) CAT XDSN(SYS3.*,SYS4.*,SYSA.*)
```

The XDSN values are coded as shown under the assumption that SYS1, SYS2, SYS3, SYS4 and SYSA are the only 4 character high-level qualifiers beginning with SYS on the system being scanned.



**Note:** SCANDIR DS(SYS1.\*\*\*,SYS2.\*\*\*) CAT is not allowed.

### Example 12

These examples are all equivalent. They scan the entire DASD subsystem for all data sets with a first qualifier of SYS1 or SYS2, excluding those with a second qualifier beginning with A.

(a)

```
SCANDIR DA(SYS1.*,SYS2.*) XDA(SYS1.A*,SYS2.A*)
```

(b)

```
SCANDIR DA(SYS1.* +
SYS2.*) +
XDA(SYS1.A* +
SYS2.A*)
```

(c)

```
SCANDIR DA(SYS1.*) +
DA(SYS2.*) +
XDA(SYS1.A*) +
XDA(SYS2.A*)
```

(d)

```
SCANDIR DA(SYS1.*) XDA(SYS1.A*) +
DA(SYS2.*) XDA(SYS2.A*)
```

(e)

```
SCANDIR DA(SYS1.*) XDSN(SYS1.A* SYS2.A*) DS(SYS2.*)
```

## Designing Inquisitor requests

When constructing statements for the Inquisitor SYSIN file, try to combine all selection and exclusion criteria to form a single SCANDIR request. A single Inquisitor request will not scan a VTOC or a library more than once.

It can be difficult to formulate a system scan into a single CATALOG request, meaning that when the CATALOG operand is used, multiple requests are coded. Ensure that no data set will be scanned by more than one SCANDIR CATALOG request by excluding as many data set name patterns from each request as necessary. Data set name exclusions may not be necessary if all CATALOG search selection masks represent disjoint parts of the name space.

The example shown here uses the XDA operand to prevent SYS1.LINKLIB from being scanned more than once:

```
SCANDIR DA(SYS1.***) CATALOG
SCANDIR DA(SYS%.LINKLIB) XDA(SYS1.LINKLIB) CATALOG
```

As well as using the selection and exclusion facilities to ensure completeness, they can also be used to improve performance and efficiency by excluding DASD volumes which do not contain program libraries. Although a volume with no program libraries can be scanned quickly, processing duration might be reduced if such volumes can be excluded from an Inquisitor scan.

For example, volumes that only contain databases, or temporary data sets, do not have any files suitable for Inquisitor processing, but the VTOCs of those volumes are still read unless excluded by the appropriate selection criteria.

To illustrate this further, consider a system with these DASD subsystem usage elements:

### System platform

Non-SMS and storage group SYSTEM.

### Work pool

Storage group TEMP containing temporary and short-lived (two days) permanent files.

### TSO

Storage groups TSOONE and TSOTWO.

### Non-DB application

Non-SMS and storage groups BATCH1 and BATCH2.

### Databases

Non-SMS volumes DBA001 to DBA099 and SMS storage groups DB01, DB02, and DB03.

The scanning of this configuration is to be carried out with the following assumptions:

- No need for data from libraries that do not exist for more than two days.
- No program libraries on database volumes.
- Applications combine their program libraries and non-database files.
- TSO users can have program libraries.
- Management requires information regarding all potentially permanent executable software.

To acquire Inquisitor data from all useful sources without processing volumes more than once, and without processing irrelevant volumes, you can specify multiple requests in a single Inquisitor run. For example:

```
SCANDIR SG(SYSTEM)
SCANDIR SG(TSO*)
SCANDIR SG(BATCH*)
SCANDIR NONSMS XVOL(DB*)
```

This can be consolidated into a single request giving the same result. For example:

```
SCANDIR SG(SYSTEM TSO* BATCH*) NONSMS XVOL (DB*)
```

## Controlling the data extraction level

When performing a system scan, the SCANDIR verb is usually sufficient. For most libraries, SCANDIR is able to collect all the necessary information from the directory entries without the need to access member contents. For PDSE libraries, this includes collecting the bind (or link edit) date. For some specific system modules, SCANDIR will also analyze the member contents to extract additional data necessary to determine the software level of those modules.

If it is important to collect the bind dates of PDS load modules, then the SCANPGM verb can be used instead of SCANDIR. However, because SCANPGM reads multiple blocks for every member, the elapsed time required to scan each PDS library will increase by several hundred percent.

To perform maximum data extraction from every scanned program, use the SCANPGM verb with the FULLIDR keyword. This combination will greatly increase the elapsed time it takes to scan PDSE libraries as well as PDS libraries, so it is not normally expected to be used.

## Extracting LE compile unit information

Specifying the FULLIDR keyword on a SCANPGM request will also allow the Inquisitor to extract information about LE compile units. Such information is stored within the program object code when a program is compiled by an LE-family compiler such as current COBOL and PL/I compilers.

The data that can be tracked for each compile unit within a scanned program includes:

- The compile date.
- The compiler level.
- The ARCH (architecture level) setting.
- The OPT (optimization level) setting.
- The DATA DIVISION statement count (for COBOL only).
- The PROCEDURE DIVISION statement count (for COBOL only).

Because of the additional resource consumption of a SCANPGM FULLIDR request over the usual SCANDIR request, it is not anticipated that a full system scan would be performed to collect this data, but rather a scan targeted to relevant application program libraries. The data from this limited scan would be used to form a purpose-built repository where data base queries can be used to extract information of interest.

When the time comes to update the system's LE compile application status, the repository would be deleted and recreated from a new targeted scan. To ascertain usage history data for these application programs, relevant queries would be directed to the main system repository where the usage data is imported.

## Scanning migrated libraries

The Inquisitor locates load libraries by either scanning the VTOC of online volumes, or by searching the system catalog (CATALOG) for relevant data sets. When you use the Catalog Search Interface, you can return data sets for migrated libraries. VTOC scans do not find migrated data sets.

When the keyword CATALOG is specified in a request statement, the Inquisitor passes the data set name selection mask to the Catalog Search Interface (CSI) to search for the catalog entries. It is possible that one or more of the catalog entries returned by the CSI are for a data set that has been migrated. In contrast, VTOC scans do not find migrated data sets.

Inquisitor processing of migrated data sets found by the CSI involves dynamic allocation which then triggers the recall of the data set. Recalls increase Inquisitor processing time. The processing leaves the data set in a recalled status.

The Inquisitor looks at the volume serial number in the catalog entry to determine if a data set is migrated or not. A data set is considered to have been migrated if its catalog entry indicates a volume serial number of either MIGRAT or ARCIVE.

To suppress the processing of all migrated data sets, specify the NORECALL keyword on each Inquisitor request.

## Integration with DFHSM

If you are using the MCDS file allocation, and a data set cataloged on volume MIGRAT is encountered, the Inquisitor can read the data set record from the DFHSM Migration Control Data Set (MCDS) to verify that the data has the attributes of a program library. If the MCDS record is not found, the data set is ignored and processing is bypassed, avoiding a DFHSM error condition. If the data set does not have partitioned organization, an undefined record format, and a block size of at least 1024, the Inquisitor ignores the data set, avoiding the recall of many data sets which are not program libraries.

For systems with DFHSM space management functions, you can use the request keywords NOML2 and REMIG. The MCDS file allocation is a prerequisite for using the following keywords:

### **NOML2**

Specifies that data sets migrated to level 2 are excluded from the scan.

### **REMIG**

Specifies that after a recalled data set is processed by the Inquisitor, the Inquisitor requests DFHSM to remigrate the data set. The Inquisitor does not wait for the migration to complete, but begins to process the next data set immediately after making the request to DFHSM. Migration level 2 is never specified by the

Inquisitor for the migration, even if the data set was recalled from ML2. (However, it might be selected by DFHSM as a result of SMS management class settings.)



**Note:**

Any combination of REMIGRATE, NOML2, and NORECALL is valid. Specifying NORECALL means NOML2 and REMIGRATE have no effect.

In the case where you want to scan all relevant migrated program libraries and do not want any such libraries explicitly remigrated afterward, you would not code any of the NORECALL, NOML2 and REMIGRATE keywords. In this instance, the MCDS file allocation, though optional, can still be used to great advantage.

## Scanning generation data sets

Catalog Search Interface requests issued by the Inquisitor are limited to non-VSAM type A catalog entries. Generation data sets (which are members of a generation data group) are not scanned by Inquisitor CATALOG requests but can be processed by Inquisitor VTOC scans. Consider excluding generation data sets if you back up program libraries using generation data sets.

To exclude generation data sets from a VTOC scan request, specify a suitable data set exclusion mask, for example:

```
XDA(*.G%%%%V00)
```

## Logical Volume Mapping

### Preserving usage trends across platform upgrades

Program libraries are identified by their data set name and the volume serial number of the disk on which they reside. Program usage is attributed to these libraries in the data base. Historical usage trends can be built up over time for these software libraries. However, when a software maintenance cycle causes a program library to be replaced by a newer version of the library on a different volume, or when DFHSM processing causes a program library to be relocated to another volume, the historical connection with the usage of the library on the original volume is lost.

For example, upgrading the system platform with a new set of volumes would mean that reporting the long-term usage trend for a particular program such as IDCAMS from the SYS1.LINKLIB library requires generating several reports instead of one, even though the active SYS1.LINKLIB data set may have always resided on the IPL volume.

To counteract this, an optional facility is available where physical DASD volumes as seen by z/OS can be mapped to logical volume sets which persist beyond the time individual physical volumes are part of that logical set. With this approach, historical connections are maintained for functional program libraries which are relocated as DASD is reorganized and renewed.

### The volume mapping process

The mapping is achieved by supplying simple assignment statements in a sequential file allocated using the HSIDAMAP file name. This file is processed by the HSIPVMAP program. HSIPVMAP is called by the Inquisitor and by the Usage Monitor

writer task to translate the selected real volume serial numbers to specified 6-character strings to be considered as the volume serial numbers in data base and report processing.

The assignment statements consist of a left side, an equals sign, and a right side. Volume serial numbers encountered in the collected data which match the left side are converted to the string on the right side. The statements are processed in the order they exist in the HSIDAMAP file, and so the earliest matching statement will be used.

It is important that both the Inquisitor and the Usage Monitor process that same volume logical mapping assignments so that usage can be attributed to discovered inventory. The Usage Monitor writer task will process the HSIDAMAP file at the end of each collection cycle, so there is no need to recycle or refresh the Usage Monitor to activate updates to the file.

Real volume serial numbers are selected based on the left side of the assignment statement, and replaced in the data with the value specified on the right side of the assignment statement. Generic masking characters and system symbols may be used to generalize the mapping process so that the statements do not have to always be updated as scheduled volume reconfigurations occur.

**Historical note:** Users of older releases may recall the SYMVOL operand of SCANDIR, and the SYM(Y) setting of the Usage Monitor, both of which are now defunct. These allowed volume serial numbers to be represented by their symbol names. This function can be replicated using volume mapping by specifying the symbol name with two leading ampersands on the right side of an assignment statement. However, such usage of logical volume mapping is not supported unless the symbol represents the same physical volume on all relevant systems. This last restriction points to why SYMVOL and SYM(Y) were removed.

### Implications for the PLX setting

The Inquisitor program HSIPINQ allows PLX=Y to be specified in its program parameter. This setting instructs Usage Import to match usage to inventory using the SYSPLEX name instead of the system identifier. This feature provides for eliminating regular Inquisitor scans on multiple systems which share the same DASD configuration. That is, after initial scans from all systems, PLX=Y allows future scans from a single system to keep the inventory up to date for all systems in the same SYSPLEX with a DASD configuration exactly matching (or entirely contained within) the DASD configuration of the primary system on which the DASD scans are to be performed on an ongoing basis.

The use of the logical volume mapping facility does not alter PLX setting requirements since PLX=Y is still permissible if all volumes are mapped to the same logical volume set on all relevant systems.

However, in cases where volume mapping depends on specific volume uses (such as IPL volume) and those uses are not the same across all relevant systems (such as the IPL volume is not shared by all relevant systems), the use of PLX=Y is not supported.

### Implications of changing the volume mapping

If you add new volume mapping statements which apply only to volumes not yet processed, then this is equivalent to setting up the statements before performing any DASD scan or usage data collection, and so there is no data inconsistency. Similarly, it is safe to remove statements which apply only to volumes which have been permanently removed from the DASD subsystem.

However, introducing logical volume mapping assignment statements which change the mapping for volumes which have already been processed is equivalent to relocating the libraries on those volumes to new volumes. That is, the historical connection with previous usage of those libraries will be broken.

In such a case, usage already assigned to previously unmapped volumes will be lost. There is currently no mechanism to transfer previously accumulated usage across to the new mappings.

A data set name is unique within the scope of a single DASD volume. Logical volume mapping allows multiple data sets with the same name to appear to reside on the same DASD volume. Many-to-one mappings result in a loss of detail that cannot be exposed by subsequent reporting. This information loss may be acceptable if it improves the reportability of other information such as trends over time which may be requested by local management. Make sure you have thought out all the consequences of this before implementing such a mapping scheme.

For example, consider the scheme where all z/OS IPL volumes were labelled as RESvri where v is the version, r is the release, and i is the iteration. So, the ninth iteration of the z/OS 2.3 IPL volume is labelled RES239, and RES1DG would be the label of the sixteenth iteration of the z/OS 1.13 IPL volume.

The mapping **RES\*=<z/OS>** might be intended to preserve usage data for libraries such as SYS1.LINKLIB, but what else flows from this? For a start, data sets from all IPL volumes will appear to contain software from the latest z/OS release that is found on DASD, even though much of it will be from a different release, and possibly from a different version. This is because the latest level is always assigned when there are multiple levels that fit the data.

Mappings of **RES1\*=<z/OSV1>** and **RES2\*=<z/OSV2>** will at least allow identifying the correct program product or version, but accurate tracking of specific releases is still not possible.

Consider the following set of logical volume mapping assignments:

```
RES1D%=Z/OS1D
RES21%=Z/OS21
RES22%=Z/OS22
RES23%=Z/OS23
RES24%=z/OS24
```

This mapping set would allow each release of z/OS to be separately identified with each release's software usage being tracked. Volumes at different maintenance levels of the same release would be treated as a single volume, but this may be an acceptable loss of detail to make longer usage trends available for reporting.

Now consider grouping the usage by system rather than by OS release. The mapping **&SYSR1.=<&SMF.>** will preserve usage history for the data sets on each system's IPL volume no matter how frequently the IPL volume is cycled to a new maintenance level. As IPL volumes are switched and a new DASD scan is imported, the software levels recorded in the data base will be updated, but usage trend reports can still include data from older software levels. Such a mapping scheme could be extended to platform volumes if local volume serial naming conventions are suitable.

Bear in mind that if a program is used via a STEPLIB to a data set on an IPL volume which is not the system's current IPL volume, then that usage will be recorded against the real volume serial (assuming no other active mappings applied), but that will be correctly attributed to the software inventory from the DASD scan performed on the same system with the same

set of logical volume mappings. In this scenario, each system would require a DASD scan on an ongoing basis (that is, PLX=Y would never be used) because the systems sharing the DASD would not have identical mappings.

### Volume symbol mapping file

When called by the Inquisitor or the Usage Monitor, the HSIPVMAP program accesses the logical volume mapping file via the HSIDAMAP data definition (DD). The logical volume mapping facility is only used if the HSIDAMAP file allocation is present, and if the file contains valid volume symbol mapping assignment statements, and if any of these statements apply to volumes being processed. There are no specific Inquisitor or Usage Monitor parameters, settings or statement keywords which control this facility.

The assignment statements in the HSIDAMAP file consist of a left side character string specifying the volume serial numbers which will be replaced by the statement's operation, an equals sign, and a right side character string specifying the volume serial number to be imported into the data base.

Syntax requirements of the HSIDAMAP file are:

- Data from a record located after a blank or after column 72 (whichever comes first) is discarded before validation. The remaining data is referred to as *active text* in the points below.
- Because of the first point, all statements must start in column 1.
- No continuations across record boundaries are allowed.
- Active text without an equals sign is treated as a comment.
- All active text non-display characters are translated to periods. (EBCDIC code points in the x'40' to x'FE' range deemed to be display characters.)
- DBCS is not supported. DBCS characters cannot be used in volume serial numbers.
- If an ampersand is present in the active text then the system symbol substitution routine is called to perform symbol resolution.
- If the left side and/or the right side evaluate to a string longer than 6 characters then the first 6 characters will be used.
- If the left side and/or the right side evaluate to a string shorter than 6 characters then the string will be extended with blanks to a length of 6 characters.
- The first or only equals sign must be followed by a non-blank. (There is nothing to stop the use of an equals sign in the right side character string.) That is, the right side cannot be a null string.
- Generic masking characters can only be used on the left side. These characters are treated as literals if used on the right side.
- The generic masking characters are a percent sign for any single character and an asterisk for any group of zero or more characters.
- If the left side evaluates to six asterisks, it will be replaced by the current IPL volume serial number.
- Symbols are allowed in the left side and the right side character strings.
- System symbols plus the symbols &SMF (SMF system identifier) and &SYSLPAR (LPAR name) can be used. Note that &SYSLPAR may resolve to a null string if z/OS is running in a virtual machine.

Further recommendations for HSIDAMAP statements are:

- Do not use an ampersand character unless it is to denote the start of a symbol name.
- Do not use system dynamic symbols.
- Exploit system static symbols where appropriate so that the same set of statements can be used on multiple systems.
- Do not attempt to convert a statement into a comment by simply inserting an asterisk in column 1. Inserting a blank, or an asterisk and a blank at the start of the statement will convert it to a comment.
- Consider using a character in the right side string which is not a valid volume serial number character. This will prevent name space clashes between logical volume set names and real volume serial numbers, and also make it plain to report readers that the displayed volume is the result of a logical mapping.
- Only use EBCDIC characters in the right side string which reliably translate to invariant ASCII characters so that the string can be reliably rendered by the Analyzer in reports without any dependence on web browser language and code page settings.

The HSIDAMAP file may contain either fixed-length or variable-length records. Sequential concatenations of unlike data sets are supported. If you decide to use this facility, you might find it convenient to store the volume symbol mapping statements in a member of your customized PARMLIB library which was created by the HSISCUST process.

Because invalid statements are ignored, you may want to test the statements before using them in production. To do this, run the HSIPINQ program with SYSPRINT allocated to SYSOUT, SYSIN allocated to DUMMY and HSIDAMAP allocated to your volume mapping statement file. The absence of any output files will cause a condition code of 16, but the active mapping status will still be reported.

### Volume mapping statement examples

Consider some sample statements.

```
TSO=+TSO+ /* this is a valid statement followed by a comment */
*TSO=+TSO+ so is this – text after a blank is a comment
* TSO=+TSO+ this whole line is a comment
```

The first statement would rename volume TSO to volume +TSO+ in the collected data. The second statement would rename volume serial numbers ending in TSO (such as TSO, 9TSO, 99TSO and 999TSO) to +TSO+. The third statement is a comment due to the blank in column 2 being situated before the assignment statement.

```
*****=SYSRES (6 asterisks on left treated as a special case)
*****=SYSRES (only the first 6 chars are used)
&SYSR1=SYSRES (= and e-o-r also flag end of symbol name)
&SYSR1.=SYSRES
```

These four statements are functionally equivalent, and would cause the IPL volume serial number to be replaced by the literal SYSRES.

```
WORK*=WORK* <--- lump WORK volumes together
PUB%%%=PUB%%% <--- lump PUBLIC volumes together
```

The first statement would rename any volume serial starting with WORK to WORK\* in the collected data. The second statement would rename any 6-character volume serial starting with PUB to PUB%%% in the collected data.

```
&SYSCLONEDISK=<CLON>
&SYSCLONE.DISK=<CLON>
```

where &SYSCLONE is a symbol resolving to S1.

The first statement has no effect because the literal &SYSCL cannot match any real volume serial number. The absence of a period to flag the end of the symbol name prevented any symbol substitution because the symbol &SYSCLONEDISK does not exist. The second statement will cause volume S1DISK to be reported as volume <CLON>.

```
&SYSR1=**&SMF <--- Home system residence volume
%%RES=*OTHR <--- Did we STEPLIB or JOBLIB to inactive SYSRES?
```

where all systems' IPL volumes have volume serial numbers with the fourth to sixth characters being equal to RES.

The first statement would cause the IPL volume to be reported as a volume serial number made up of two asterisks concatenated with the system identifier. Programs found to be on the IPL volumes of other systems, or perhaps on residence volumes not even in active use, would be reported as residing on volume \*OTHR (other residence volume).

```
&IMSVS=&&IMSVS <--- Show current IMS volume as its symbol name
&DB2DA=&&DB2DA <--- Show current DB2 volume as its symbol name
```

These two statements would cause the volumes with serial numbers which match the values of the system symbols &IMSVS and &DB2DA to be reported as &IMSVS and &DB2DA respectively.

## Collecting information about the I/O configuration

The Inquisitor can scan the input and output (I/O) configuration of a z/OS® system to collect information about the use of hardware assets such as storage devices. The SCANDEV command is used to request such a scan.

When you run the SCANDEV command, two additional types of records are generated which describe device groups and channel paths. Consideration of I/O devices is limited to those devices which are online at the time of the scan.

A device group is a contiguous block of device numbers, not including offline devices, where the device type, control unit type and serial number, and online channel path connectivity is the same. The channel path type is collected for each channel path used to connect to an online I/O device.

A channel that does not provide an online path to any online device is not reported even if the channel is configured online to the z/OS® system.

## Collecting UNIX files with the Inquisitor for z/OS UNIX

The Inquisitor for z/OS® UNIX™ is a program that collects information about executable software existing in HFS and zFS data sets currently mounted and accessible to z/OS® UNIX™. The Inquisitor Import program takes the collected data as input to form the basis of your z/OS® UNIX™ software inventory.

### Inquisitor for z/OS® UNIX® overview

The Inquisitor for z/OS® UNIX® produces a set of record types which are different from those produced by the Inquisitor for z/OS®. However, both programs collect the same types of information about installed software.

The Inquisitor for z/OS® UNIX® processes the hierarchical file system (HFS) root directory, as well as all subdirectories. For this reason, the program must run with a UID that allows access to all directories and programs to be examined. If the Inquisitor for z/OS® UNIX® does not have permission to access a directory, then no information is collected from that directory, or any of its subdirectories.

The HSIXROOT file is used to nominate one or more directories to be considered root directories. When specified, only the nominated directories and their subdirectories are processed. This facility is useful when only a subset of the file hierarchy needs to be scanned.

The HSIXOMIT file is used to nominate one or more directories which are to be omitted or excluded from the scan, together with all of their subdirectories. This facility can be used to reduce resource consumption by preventing parts of the UNIX® file hierarchy known not to have any executable software from being scanned.

## Running the Inquisitor for z/OS® UNIX® program

The HSISINQU job in the JCLLIB library performs the Inquisitor for z/OS® UNIX® collection. This job is generated from the HSISCUST post-installation customization job.

### About this task

Run-time for this job depends on the size and complexity of the UNIX® directory structure to be scanned. Run this job during off-peak periods.

### Procedure

1. In the HSISINQU job, check the values for the following parameter and change if necessary:
  - The **PLX** parameter is set to **N** (no). Review information about the **PLX** parameter before you use **PLX=Y** – shared DASD is NOT sufficient to use this for a z/OS UNIX file system scan.
  - The **PACK** parameter is set to 1 to request that zipped output is written using the fastest level of the **deflate** algorithm. Higher values up to 9 can be used for better compression, but they will use more CPU time. Specify **PACK=0** if use of the **shrink** zip algorithm is required.
  - The **LLQ** parameter is set to **Z&SMF**. You can change this value if you want to generate data sets with unique names without changing the JCL library. This value is set when the HSISINQU job is submitted.
2. In the program parameter string, you can specify a report message level, an override to the system identifier, and whether you want compressed or uncompressed output. Use commas to separate the various settings specified within the program parameter string.
3. Run the HSISINQU job.

### PLX parameter of the z/OS® UNIX® Inquisitor program

While the earlier discussion about the PLX parameter setting for the z/OS Inquisitor program is also broadly applicable to the z/OS UNIX Inquisitor, it is important to understand that using PLX=Y for one program does not imply that PLX=Y should be used for the other program.

For the z/OS Inquisitor (which scans PDS and PDSE libraries), PLX=Y should only be specified when all the relevant systems have access to all the same libraries, and for this it is usually sufficient to share the DASD and catalog configurations.

For the z/OS UNIX Inquisitor, PLX=Y should only be specified when all the relevant systems have access to all the same UNIX files. Sharing DASD and catalogs is not sufficient to achieve this. Systems in a sysplex must be explicitly configured to share the same UNIX file system before it is suitable to use the PLX=Y setting of the UNIX Inquisitor program.

## Inquisitor for z/OS® UNIX® program parameters and files

The Inquisitor for z/OS® UNIX® program has mandatory and optional parameters that affect how data is collected. The program uses some mandatory files as well as some optional files.

**Table 11. Parameter settings for Inquisitor for z/OS® UNIX®**

Parameter	Description
PTHMSG	Requests that a message is written to HSIXMSG each time a directory is opened or closed.
PGMMMSG	Requests that a message is written to HSIXMSG each time an executable file is processed.
ALLMSG	Requests both PTHMSG and PGMMMSG message logging.
NOHOST	Requests that the call to HSIPHOST to collect the TCPIP host name and IP address is bypassed.
SID=	The value is up to 4 characters long and specifies the system identifier to be contained in the data output from the Inquisitor. If the SID identifier override is omitted, the system SMF identifier is used. The SID parameter setting is used when the SMF system identifier of a system is not unique. For example: SID=SYS2
PLX=	The parameter is used to identify if the Inquisitor data being collected is from a UNIX file system shared by all systems scanned with the same sysplex name. The value is either Y or N. If the PLX parameter is not used, the default value of N is created in the Inquisitor header record.
PLEXNAME=	The value is up to 8 characters long, and specifies the sysplex name to be contained in the data output from the Inquisitor. If the PLEXNAME identifier override is omitted, the actual sysplex name is used. The primary purpose of the PLEXNAME parameter is to provide a means for controlling the scope of sysplex-wide inventory updates.
PACK=	The value is a single decimal digit (0-9) and specifies the level of compaction that will be used to write zipped output. The value of 0 specifies that <i>shrink</i> will be used. Values in the 1 to 9 range specify the compaction level of <i>deflate</i> to be used. PACK=1 is the program default.
LLQ=	This parameter is used to specify a suffix string made up of one or more data set name qualifiers to be appended to the data set name of the HSIXZIP and HSIXOUT data set. Its maximum length is 44 characters. It may contain both static and dynamic system symbols, and the user symbols &SMF. (SMF system identifier) and &SYSLPAR. (LPAR name) supplied by the Inquisitor. Use the LLQ setting when you need to create uniquely named data sets without changing the JCL.

**Table 12. Files used by the Inquisitor for z/OS® UNIX®**

Filename	Description
HSIXMSG	Report file used by HSIXINQ.

**Table 12. Files used by the Inquisitor for z/OS® UNIX® (continued)**

Filename	Description
SYSPRINT	Used by Language Environment® (LE), which is required to be in the standard module search path, and by IDCAMS when LLQ= is specified.
SYSOUT	Used by Language Environment® (LE), which is required to be in the standard module search path.
HSIXZIP	An optional output file that contains compressed Inquisitor for z/OS® data. It is written using a variable length record format. You need to provide DCB information to ensure optimal use of DASD space.  In the case where HSIXOUT is not allocated and HSIXZIP processing encounters an S213-C8 abend, the UNIX Inquisitor will attempt to write uncompressed output to this file, overriding the LRECL as appropriate.
HSIXOUT	An optional output file that contains uncompressed Inquisitor for z/OS® UNIX® data. It is not specified in the packaged sample, as the use of HSIXZIP is preferred, due to its reduced space requirements. HSIXOUT also contains variable length records. The program supplies the appropriate LRECL. By default, system determined block size is used.  If you want to direct the Inquisitor for z/OS® UNIX® output to a compressible extended-format data set, then you should use the HSIXOUT file. The HSIXZIP file employs update-in-place processing, which prevents the use of DFSMS™ compression.
HSIXROOT	An optional file which can contain one or more records; each of which specifies a directory path to be considered as a root directory to be processed. If HSIXROOT is not allocated or empty, then a forward slash (/) is the only root directory processed.
HSIXOMIT	An optional file which can contain one or more records; each of which specifies a directory path which is to be omitted from the scan. Root directories cannot be omitted.

The HSIXROOT and HSIXOMIT files have the following characteristics and attributes in common:

- There is no requirement for the file to be allocated.
- The file might be empty or allocated to DUMMY.
- The file might contain fixed length or variable length records.
- Records must not contain more than 1024 bytes of data.
- Blank records are deemed to be comments and discarded.
- Leading and trailing blanks are discarded when the directory name is extracted.
- UNIX directory names may contain embedded blanks.
- The entire record is parsed so do not use sequence numbers.
- Records with an asterisk as the first non-blank are deemed to be comments and discarded.
- If the directory path does not end in a slash, then one is appended.

## z/OS® UNIX® Inquisitor example

In this example, the requirement is for a full scan of the file system, but it is known that the DEPLOY 1 product has a vast subdirectory structure containing thousands of files, with the actual software for the product being confined to its bin subdirectory. Accordingly, to reduce unproductive processing the decision is made to exclude the product's files from the z/OS® UNIX® Inquisitor scan except for its bin subdirectory. The main DEPLOY 1 directory is called deploy1 and it is a subdirectory of the system's root directory.

To implement this exclusion filtering, the HSIXROOT file and the HSIXOMIT file contain the records as indicated below.

HSIXROOT contents:

```
* System root directory
/
* DEPLOY-1 executable program directory
/deploy1/bin/
```

HSIXOMIT contents:

```
* DEPLOY-1 mount-point directory
/deploy1/
```

The result is as follows:

- The z/OS® UNIX® Inquisitor will begin scanning the entries in the system root directory.
- As each subdirectory is discovered, the subdirectory path name will be compared to path names supplied from the HSIXOMIT file and discarded if a match is found. In this way, the /deploy1 directory and all its subdirectories will be excluded from the scan.
- After the remainder of the file system has been scanned, the z/OS® UNIX® Inquisitor will scan the /deploy1/bin directory and its subdirectories if it has any. Again, subdirectory path names will be compared with paths named in the HSIXOMIT file, but no exact matches will be found since none of the names can equal /deploy1/.

## Security considerations

If you want to collect all relevant z/OS® UNIX® data, you must have access to all UNIX® directories, including the root directory. This access ensures that all z/OS® UNIX® data is collected.

To allow the Inquisitor unrestricted read access to all z/OS® UNIX® files, consider using the UNIXPRIV RACF® Resource Class, which alleviates the need for UID(0).

The following sample definition can be used by your Security Administrator to define, permit, activate, and RACLIST the RACF® UNIXPRIV Class:

```
RDEL UNIXPRIV SUPERUSER.FILESYS.**
RDEF UNIXPRIV SUPERUSER.FILESYS.** UACC(NONE) OWNER(IBMUSER)
PE SUPERUSER.FILESYS.** CLASS(UNIXPRIV) RESET
PE SUPERUSER.FILESYS.** CLASS(UNIXPRIV) ID(USERONE) ACCESS(READ)
SETR CLASSACT(UNIXPRIV)
SETR RACLIST(UNIXPRIV)
SETR RACLIST(UNIXPRIV) REFR
```

## Collecting usage data with the Usage Monitor

The Usage Monitor is a server address space that runs as a started task. Work is queued to the Usage Monitor from all address spaces where programs are used. The Usage Monitor moves captured program usage data into the collection repository and periodically writes the accumulated data to a sequential file. The Usage Monitor runs APF authorized and is non-swappable.

---

Related information

[Importing usage data on page 123](#)

### Setting up the Usage Monitor

The Usage Monitor uses the HSIJMON job in the JCLLIB library. This job is generated from the HSISCUST post-installation customization job. This job will call the HSIJMON procedure from the JCLLIB library.

Parameters for the Usage Monitor job are HSISMNPM member in the PARMLIB library.

### Files used by the Usage Monitor

The Usage Monitor has three product-specific files. They are:

#### **HSIZIN**

A sequential file consisting of fixed length 80 byte records. It contains initial commands which are run before data collection becomes active. It must contain the data set prefix to be used for dynamically created output files. The prefix can be changed later by an operator MODIFY command.

HSIZIN is opened, read, and closed during initialization processing. Do not specify FREE=CLOSE in the JCL for HSIZIN, or refresh processing is not possible.

Data set &HSIINST . . &DB . . UM . HLQIDS contains the high-level qualifier listing for products and is populated by the IQ Import job (HSISIQIM). To minimize the number of records to be created by the Usage Monitor, only usage events that match the list of products in this data set are generated. To activate this facility, in `//HSIZIN`, uncomment data set &HSIINST . . &DB . . UM . HLQIDS as described in PROC HSIJMON.

#### **HSIZMSG**

A log file which contains the initial commands issued, and which indicates their degree of success. It also contains regular status reports, writer reports, refresh reports (when appropriate), and a termination report. It consists of fixed-length 121-byte records.

**HSIDAMAP**

An optional file containing logical volume mapping assignment statements.

Output files containing program usage data are dynamically allocated by the Usage Monitor. The data set name prefix, the allocation unit, and the primary and secondary space allocation quantities (in tracks), need to be customized for the target system. This is done in the PARMLIB member HSISMNPM.

**Using exclusion masks to reduce data**

The data from a significant number of program usage events does not contribute meaningfully to the task of managing the software inventory. To reduce the processing of this unnecessary data, two mechanisms that allow some data to be excluded from collection are provided. They are exclusion masking based on program name, and exclusion masking based on data set name.

**Filtering by program name**

A program name exclusion table exists which contains program name masks. When a program usage event is detected by the Usage Monitor, the program name is checked against entries in the program name exclusion table. When a match is found, the usage event data is discarded. Program name exclusion filtering occurs before the data set name of the program library is determined by the Usage Monitor, which makes it more efficient than data set name filtering.

Each table entry contains a program name comparison string up to 8 bytes long. The string is either an 8-byte program name, or a shorter program name prefix. When entering these strings with the EXC command, a prefix is denoted by using an asterisk as the last character.

The program name exclusion table resides in key zero common storage, and its size is always a multiple of 4,096 bytes. The minimum table size can house up to 253 entries, and the table size increases dynamically, as required. The default program name exclusion table contains entries to exclude data pertaining to the usage of many programs which are part of the operating system.

In order to add, reset, remove, or display the entries to the table, use these commands:

**EXC**

To add entries to the program name exclusion table, or to reset the table to its default contents.

**DEL**

To remove some, or all, entries from the table.

**D-X**

To display the current contents of the table.

Unlike masks added by the EXC command, default program name exclusion masks do not exclude job step program usage events. So, for example, the IEF\* default exclusion mask excludes dynamic calls and loads of program IEFBR14, but usages where IEFBR14 is invoked by JCL are not excluded by this mask.

## Filtering by calling program name

For program use events resulting from LINK, LOAD and DELETE requests (but not from ATTACH requests) an additional filtering check is made against the name of the program that issued the request. This facility allows the exclusion of usage generated by software auditing and reporting tools, as well as other administrative tools which invoke programs to report whether the owning component is enabled or disabled.

To state it another way, this is an indirect filtering facility where usage of the named program is not excluded, but programs fetched by the named program do have their usage excluded no matter what names those programs have.

There are no default entries for this filtering – all entries in this filter list are supplied via the LDX command. The LDD command is available to deactivate previously added entries. Exact program names (with no masking) up to 8 characters long must be specified when using LDX and LDD commands.

In order to add, remove, or display the entries in the calling program exclusion list, use these commands:

### **LDX**

To add one or several entries to the calling program name exclusion list.

### **LDD**

To remove one or several entries previously defined using LDX.

### **D-X**

To display active LDX exclusion entries after default and EXC exclusion entries.

## Filtering by data set name

After the Usage Monitor has ascertained the name of the data set from which a used program is fetched, it is used to decide if the usage data is retained for collection or discarded. To perform this process, three lists of data set name masks are scanned; the first is the default data set name exclusion list, the second is the dynamic data set name inclusion list, and the third is the dynamic data set name exclusion list.

The default data set name exclusion list is built during Usage Monitor initialization, and consists of the SCEERUN library, the SCEERUN2 library, SYS1.COMDLIB (containing TSO commands), SYS1.CSSLIB (containing callable services modules), and masks for data set names ending with DBDLIB and PSBLIB. The data set names of the SCEERUN and SCEERUN2 Language Environment® libraries are determined by searching the link list for specific LE modules. You can use the XDD command to deactivate any of these default exclusion entries. You can use the XDS(\*DFLT\*) command to reactivate the default data set exclude list without affecting the status of masks in other lists.

The other two lists are constructed from commands you specify either in the HSIZIN file or dynamically via the system MODIFY command.

To avoid excessive storage and processor resource consumption, keep the number of elements in each list to a minimum. This is achieved by using generic masks to cover many data set names. The inclusion mask list is provided so that specific exceptions to broad exclusion rules can be specified. If you do not supply any data set name exclusion masks, the inclusion

list does not affect data collection, but can still be used as a convenient way to collect relative usage statistics from the regular Usage Monitor status reports.

Data set name filtering occurs in the following sequence:

1. Excludes usage if the data set name matches a default exclusion mask, otherwise proceeds to step 2.
2. Includes usage if the data set name matches a mask supplied by an IDS command, otherwise proceeds to step 3.
3. Excludes usage if the data set name matches a mask supplied by an XDS command, otherwise proceeds to step 4.
4. Includes usage if the data set name does not match any of the masks.

Data set mask elements reside in key zero common storage. Each element occupies 64 bytes, and contains a data set name mask up to 44 bytes in length. You can use a percent sign as a wildcard to match any single character. You can use an asterisk as a wildcard to match any group of zero or more characters. Before the mask is stored, all occurrences of `*%` are changed to `%*`, and then all occurrences of multiple consecutive asterisks are changed to a single asterisk.

In order to add, reset, remove, or display the entries to the tables, use these commands:

#### **XDS**

To add a data set name mask to the exclusion list.

#### **IDS**

To add a data set name mask to the inclusion list.

#### **XDD**

To deactivate a data set name exclusion mask.

#### **IDD**

To deactivate a data set name inclusion mask.

#### **D-D**

To display all active data set name masks.

Both of the non-default lists have no elements until an XDS or IDS command is processed. Storage is dynamically acquired for each element as required. To ensure system integrity, XDD and IDD commands do not cause the storage of a deactivated element to be freed, but mark the element as inactive. When a deactivated mask is reactivated, the existing entry is marked as active without the further acquisition of storage.

You can use the `XDD(*ALL*)` command to deactivate all data set exclusion masks, including those in the default list. You can use the `IDD(*ALL*)` command to deactivate all data set inclusion masks.

When the Usage Monitor address space first initializes, all elements of lists that remain in storage from a previous run are freed before the processing of initial commands and the commencement of data collection.

The default exclusion list is provided to reduce overhead by discarding data that does not assist with product use identification, and while additional data set filtering is provided for local use, it is expected that for many systems no customization of data set filtering would be necessary.

## Filtering by UNIX® path name

If the mask value specified in an IDS, XDS, IDD, or XDD command contains at least one slash, the value is deemed to be a UNIX® path name mask and not a data set name mask. During processing, multiple consecutive slashes are reduced to a single slash.

UNIX® path name masks entered via IDS and XDS commands are compared to the path names specified by applications at run time and may not correspond to the path names against which usage is attributed. The main cause for this difference in path names is the use of symbolic links. The Usage Monitor writer task converts path names with symbolic links to real path names in order to match inventory discovered by the Inquisitor.

Do not use an IDD or XDD command that specifies a UNIX® path name mask because the only use for such a command is to dynamically delete a UNIX® path name mask. Most UNIX® path name masks contain lowercase alphabetic characters. The system MODIFY command interface usually changes lower case characters to upper case which prevents the mask matching the relevant active mask. To delete a UNIX® path name mask you must either recycle the Usage Monitor or use the REF command to refresh the settings from the HSIZIN file. In either case, all UNIX® path name masks are deactivated and the necessary change is to remove the IDS or XDS command that you want to deactivate from the HSIZIN file.

Similarly, because of the prevalence of lower case alphabets in UNIX® path names, you only specify IDS and XDS commands with path name masks as HSIZIN file input rather than via the MODIFY system command interface.

The length limit of 44 characters also applies to UNIX® path name masks.

## Recording CPU time

The Usage Monitor will attempt to record the CPU time used by each program. This is only done for task-type programs that receive control from the operating system's contents supervisor. Programs which are pre-loaded and then branched to will not accrue any recorded CPU time. Recorded CPU time for a program may include time for programs and services that it has invoked, including programs that have been excluded from collection, but will not include time attributed to other monitored programs.

Accumulated CPU time is logged in the collection repository when a monitored program ends. This means that CPU time for long-running jobs will either not be collected, or will be collected once when the component is shutdown, perhaps even with the bulk of the CPU time being due to activity in prior collection cycles, which could compromise the value of that data.

For this reason, the Usage Monitor can collect consumed CPU time differently for those address spaces which are classed as being long-running. For these address spaces, all the consumed CPU time will be attributed to the job step program, with the CPU time values being sourced from the SMF30CPT field of type 30, subtypes 2 and 3 SMF records. The previously described CPU time tracking at the request block level will not be performed for these address spaces.

Long-running address spaces are recognized by their job step program name. The initial list of long-running program names is formed from the system's program properties table at the time that the Usage Monitor is started. Additional names can be added by issuing the LRP command. Existing entries in the long-running program name list can be deleted by the LRD command. The Usage Monitor will deem an address space to be long-running if its job step program name matches any active entry in this name list. The Usage Monitor does not check whether any of the properties described by the PPT entry are actually assigned. Only started task and batch job address spaces are checked for being long-running.

This facility allows the Usage Monitor to report CPU time used by CICS, IMS control region, DB2 and MQ subsystem, and various other address space types without having to wait until those address spaces terminate.

In order to add, remove, or display the entries in the long-running program name list, use these commands:

#### **LRP**

To add one or several entries to the long-running program list.

#### **LRD**

To remove one or several entries from the long-running program list.

#### **D-L**

To display active long-running program name entries.

## Starting and stopping the Usage Monitor

A Usage Monitor member named HSIJMON is provided in SHSIPROC. If you want to start HSIJMON as a started task, copy the customized member from the JCLLIB to an authorized PROCLIB.

### Procedure

1. To start the Usage Monitor in normal mode, enter the following command:

```
S HSIJMON
```

2. To fully stop the Usage Monitor, enter one of the following commands:

```
P HSIJMON
F HSIJMON,STOP
F HSIJMON,END
```

These commands cause the Usage Monitor to stop data collection, attach a writer task to process the existing data in the collection repository, wait for the writer task to output the data, and then terminate.

3. To perform an immediate termination, enter the following command:

```
F HSIJMON,CAN
```

This command causes the server address space to stop data collection, detaches any running writer task which renders the output data in the data set unusable, deletes the current collection repository without writing out its contents, and terminates. If you use the z/OS® system command CANCEL to stop the Usage Monitor, its collection repository remains in storage. To clear the collection repository from storage, you must restart the Usage Monitor.

## Refresh processing for the Usage Monitor

The Usage Monitor includes commands that you can issue dynamically to alter processing but that are active only for the duration of the current Usage Monitor session. To implement a change to both the running Usage Monitor and to the initialization commands for starting subsequent Usage Monitor sessions, you can use the refresh facility.

Refresh processing involves the execution of the command stream placed in the HSIZIN file, without the requirement of stopping and restarting the Usage Monitor. As a result, refresh processing can verify the validity of the initialization

command stream so that changes are made and tested dynamically. This ensures that future Usage Monitor sessions do not encounter initialization command stream errors.

Some commands set a switch for logic control, or set a numeric value to be used during processing. These commands specify the values to be used in the future. Other commands pertaining to inclusion and exclusion masking add a mask to, or remove a mask from, the active mask list, so are part of an accumulation of commands which specify future processing.

Consider the example where several exclusion masks are active, and a change to deactivate one of the masks is required. A command to deactivate the mask might be issued dynamically, but if this change is to be made permanent, then the HSIZIN file needs to be updated. The alternative is to remove the command setting the exclusion from the HSIZIN file, and to then issue the Usage Monitor REF command to initiate a refresh.

Before the first HSIZIN command is run during refresh processing, the program mask exclusion list is set to the default list. Further, all data set name exclusion masks are deactivated, and all data set name inclusion masks are deactivated. This order of deactivation ensures that there is no loss of data that would otherwise be collected. However, there is the possibility that data which would have been excluded is collected during the short window between the reset of the mask lists and the processing of the HSIZIN commands.

The response to each command in the HSIZIN file is written to the HSIZMSG file. A summary WTO message, indicating whether any errors are found or not, is issued after refresh processing has finished.

Stopping the Usage Monitor and restarting it, produces the same active exclusion masks as a refresh. It also produces a data collection outage. For more information, see the REF command in the next topic for a list of the processes performed during a refresh operation.

## Usage Monitor commands

The Usage Monitor commands are passed to the Usage Monitor from the HSIZIN input file, or by an operator MODIFY command.

The syntax rules are as follows:

- All commands are three characters long.
- Operands or subparameters are specified in parentheses.
- Multiple subparameters are separated by commas.
- The command must not contain any embedded blanks.
- Commands must start in column one.
- Commands setting optional values (such as a volume or an SMS class) also accept parentheses () without a subparameter to clear a previously set value.

Settings are not preserved across successive runs of the Usage Monitor. Default values are set when the Usage Monitor address space initializes prior to processing the HSIZIN file.

To record the settings the Usage Monitor is using, place the display commands at the end of the HSIZIN file.

Details of each command follow.

### APF - Set APF library collection status

APF is used to specify whether output data sets written by the writer task will include a list of APF authorized libraries or not. While program HSIPINQ will collect the APF status of program libraries, it can only report that status for the system on which it executes, and it may not always be run on every system where the Usage Monitor is running. Enabling this data collection allows the data base to reflect the correct APF status of libraries for each system where the Usage Monitor is active.

▶▶ APF(  ) ▶▶

**Y**

Specifies that APF library information is to be collected.

**N**

Specifies that APF library information is not to be collected.

If no APF command is issued, then APF library information is collected. APF(Y) is the default setting.

The APF setting is only referenced by the writer task at the end of a collection cycle, and the APF library information collected represents the status at that time.

### ASZ - Specify ASID array area size

ASZ is used to specify the virtual storage size of the SCOPE=COMMON memory object which forms the area where the program management status of each address space is stored. The ASZ value is referenced each time a new extent of this area is allocated. The first extent is created when the Usage Monitor first initializes after an IPL. Secondary extents are allocated dynamically as required up to a maximum of 16 extents.

This area of storage is normally never freed, but the area can be deleted and a new area created by recycling the Usage Monitor with PARM='NEWASVT' specified on the job step EXEC JCL statement.

▶▶ ASZ( *segments* ) ▶▶

***segments***

specifies a number of segments from 1 to 200.

If no ASZ command is issued, a 16 MB area will be used. As new job steps start in any given ASID, storage is reclaimed and reused so that number of pages that need to be physically backed is kept to a minimum.

### CAP - Set hardware capacity collection status

CAP is used to specify if the Usage Monitor is to produce records containing information about the hardware capacity of the system. Collecting this information is important when hardware capacity changes dynamically.

A change to this setting does not take effect until the next collection repository switch.

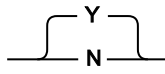
►► CAP(  ) ►►

**Y**

Specifies that hardware capacity data is collected and written out.

**N**

Specifies that hardware capacity is not collected or written out.

If no CAP command is issued, the default is CAP(Y).

**Table 13. Examples of using the CAP command**

Command purpose	Example code
Collect hardware capacity data.	F HSIJMON,CAP(Y)
Do not collect hardware capacity data.	F HSIJMON,CAP(N)

**CIC - Allow or disable program usage data from CICS® regions**

The CIC command provides a system-wide control mechanism to allow or disallow program usage data to be collected by the Usage Monitor CICS® global user exit (GLUE) program.

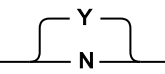
►► CIC(  ) ►►

**Y**

Specifies that customized CICS® regions are able to present program usage data to the Usage Monitor for collection.

**N**

Specifies CICS® program usage monitoring is disabled throughout the operating system image.

If no CIC command is issued, the default is CIC(Y).

**D-A - Display output allocation parameters**

D-A is used to display dynamic allocation details to be used in the creation of output data files. The data set name, DCB attributes, primary and secondary space quantities, and unit and optional volume serial number are shown.

►► D-A ►►

The following code example displays the current dynamic allocation values.

```
F HSIJMON,D-A
```

### D-C - Display the counters and statistics

D-C is used to display the Usage Monitor activity and status indicators. The purpose of this command is to assist IBM technical support in problem diagnosis. The meaning of the output generated by this command is not published.

▶▶ D-C ▶▶

The following code example displays the current value of internal Usage Monitor counters.

```
F HSIJMON,D-C
```

### D-D - Display the data set name inclusion and exclusion lists

D-D is used to display the data set name masks in the inclusion list, followed by the data set name masks in the exclusion list.

The inclusion and exclusion lists do not need to be populated in order to collect data. The absence of any entries in the exclusion list means that data collection is not filtered by program library data set names.

▶▶ D-D ▶▶

The following code example displays the current data set name inclusion and exclusion lists.

```
F HSIJMON,D-D
```

### D-I - Display the system identifier

D-I is used to display the system identifier, which is written in the output header record. It can be altered by the **SID** command.

▶▶ D-I ▶▶

The following example code displays the current system identifier used by the Usage Monitor.

```
F HSIJMON,D-I
```

### D-L - Display long-running program names

D-L is used to list the program names currently considered to be long-running. The initial list is formed from the system's program properties table active when the Usage Monitor initializes. Names can be added to the list by the LRP command, and removed from the list by the LRD command.

When the name of the job step program of a started task or batch job matches an active entry in this list, detailed CPU time consumed by programs in this step is not tracked, but the step's CPU time consumed each SMF interval is attributed to the job step program, allowing some tracking of consumed CPU time for rarely-ending address spaces.

## ►► D-L ◄◄

### D-S - Display the status settings

D-S is used to display several miscellaneous settings. Other commands are used to alter the individual settings, but this command provides a convenient way to list the current values.

## ►► D-S ◄◄

Place at the end of the HSIZIN file to confirm monitoring settings.

The following example code displays the current values of settings.

```
F HSIJMON,D-S
```

### D-T - Display the automatic switch-and-write time setting

D-T is used to display the time-of-day specified for automatic collection repository switching and consequent writer task creation. When data from after this time-of-day is detected, data collection is automatically switched to a new repository, and write-out of data in the old repository is started.

The UTC or GMT switch time is calculated using local time current at collection repository creation time. The time when a collection repository is terminated is set when it is created. Changes to the system local time offset, such as those caused by a change to daylight saving time, do not alter the UTC or GMT that the current collection repository is closed. The time of the switch after the next switch is calculated using the new local time.

## ►► D-T ◄◄

The following example code displays the current automatic switch-and-write time setting.

```
F HSIJMON,D-T
```

### D-X - Display the active exclude list

D-X is used to display the active program name mask exclude list. Data is not collected for programs with names that match the mask in any active entry in the exclude list.

## ►► D-X ◄◄

The following example code displays the current exclude list entries.

```
F HSIJMON,D-X
```

### DCB - Set output DCB attributes

DCB is used to set DCB attributes, which are optimal for a specific device type.

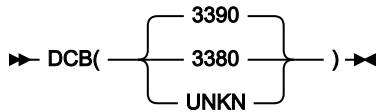

If no DCB command is issued, the default is DCB(3390).

### DCB(3390)

Sets the output DCB to

```
RECFM=VB,LRECL=27994,BLKSIZE=27998
```

Use when the output device has 3390 compatible geometry.

### DCB(3380)

Sets the output DCB to

```
RECFM=VB,LRECL=23472,BLKSIZE=23476
```

Use when the output device has 3380 compatible geometry.

### DCB(UNKN)

Sets the output DCB to

```
RECFM=VBS,LRECL=32756,BLKSIZE=0
```

The system determines the optimal block size for the device used by dynamic allocation. Use when the output device type is not known until allocation time.

Some FTP products do not process a file with RECFM=VBS correctly, even when no records are actually spanned.

## DCL - Set the data set SMS data class

The DCL command is used to override the data class that is assigned to dynamically created output data sets by the system's ACS routines. You may use this, for example, to assign a data class that is not eligible to be marked SMS compressible so that the Usage Monitor can output zipped data.

➔ DCL( *dataclas* ) ➔

### *dataclas*

specifies a 1 – 8 character SMS data class name

## DEL - Deleting program mask entries

DEL is used to remove program name masks from filter tables. Both default and user-added entries can be removed. The required operand specifies one or more program name masks.

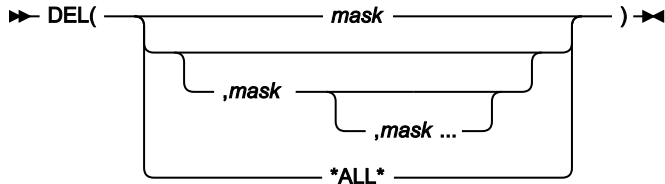

**mask**

Specifies a 1 - 8 character program name mask. Any wildcard characters in the mask are treated as literals for the purposes of finding the mask to delete.

**\*ALL\***

Specifies every currently active mask. This mask cannot be specified with any other mask.

Except for short test periods, it is expected that default exclusion masks such as IGG\* remain active.

**Table 14. Examples of using the DEL command**

Command purpose	Example code
Remove all entries, so that all possible programs are monitored.	F HSIJMON,DEL(*ALL*)
Remove exclusion masks to monitor LE and REXX™ modules.	F HSIJMON,DEL(CEE*,IRX*)
Remove an exclusion mask to monitor the program called CEE.	F HSIJMON,DEL(CEE)

**DSN - Setting the data set name prefix**

DSN is used to specify the first part of the data set names used for the output files. The prefix is specified in the required operand. The HSIJIN file must contain a DSN command.

You can use symbols in the construction of the data set name prefix. Available symbols include all z/OS® static symbols, &SMF, the SMF identifier for the system, and &SYSLPAR, the logical partition name for the system.



**dsnpref**

Specifies a 1 - 26 character data set name prefix. It can contain one or more data set qualifiers, and must not end in a period after any symbol substitution.

Usage Monitor needs RACF® ALTER access to the data sets to be able to create them.

The following example code shows how to get output files with names of the form

`SYS3.HSI.HSIJMON.Dyyyyddd.Thhmmssst:`

```
F HSIJMON,DSN(SYS3.HSI.HSIJMON)
```

### DUR - Set execution duration

DUR is used to specify a fixed short-term execution duration of the Usage Monitor started task. When the specified time has elapsed the Usage Monitor will terminate automatically. The Usage Monitor stop time is calculated by adding the specified duration to the current time when the command is processed.

Any subsequent WRT commands are ignored.

The DUR command is not normally used in standard operations where the Usage Monitor is to remain active until system shutdown. When it is used, it is normally placed in the HSIJIN file to specify a predetermined length of execution for sampling or testing purposes.

►► DUR(*hhmm*) ◄◄

#### *hhmm*

Specifies a time duration in hour and minute notation. The value must be four decimal digits. The minimum value is 0001 and the maximum value is 2400. The last two digits (mm) must be in the 00 - 59 range.

The following example code instructs the Usage Monitor to stop after 150 minutes.

```
F HSIJMON,DUR(0230)
```

### EXC - Adding program mask exclusion entries

EXC is used to add program name masks to the exclusion table. The required operand specifies one or more program name masks.

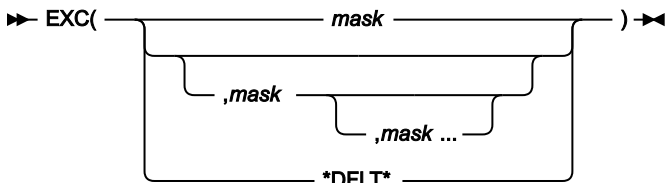

#### *mask*

Specifies a 1 - 8 character program name mask. If the mask ends in an asterisk only, characters before the asterisk are compared. Otherwise, an exact program name is deemed to have been specified.

#### *\*DFLT\**

Specifies every supplied default entry in the exclusion table is to be made active, and all user-added entries are to be removed from the exclusion table. This mask cannot be specified with any other mask.

Except for short test periods, it is expected that default exclusion masks such as IGG\* would remain active.

**Table 15. Examples of using the EXC command**

Command purpose	Example code
Reset the exclusion table to its default status.	F HSIJMON,EXC(*DFLT*)
Exclude the collection of data for Language Environment® modules and REXX™ modules.	F HSIJMON,EXC(CEE*,IRX*)
Exclude the collection of data for the program CEE.	F HSIJMON,EXC(CEE)

**HOF - Adjust for hypervisor STCK TOD clock offset**

HOF is used to control whether the TOD clock offset in a logical partition is to be applied to collected data, or not. When HOF(N) is set, data timestamps are derived from the local time as supplied by z/OS®. When HOF(Y) is set, the hypervisor STCK date and time offset from field SMF89HOF in SMF type 89 records is subtracted from z/OS® local time to form the collected timestamp values.

For Usage Monitor data, the HOF setting at the time that the writer task is attached after the closure (or switch) of a collection repository is used.

For Inquisitor data, the HOF setting active at the time of the Inquisitor program initialization is used.

HOF(Y) will not cause any change to data timestamp values unless the Usage Monitor has processed a type 89 SMF record. For this to occur, SMF parameter settings must specify the collection of type 89 records, and at least one SMF interval must have ended while the Usage Monitor is active before the output file data generation commenced.

If the Usage Monitor has been stopped before an Inquisitor scan commences, the Inquisitor program uses the HOF status current at the time of Usage Monitor termination.



**Y**

Specifies the hypervisor STCK TOD clock offset will be used to adjust date and time values present in collected data.

**N**

Specifies the date and time values present in collected data will be based wholly on the local time, as maintained by z/OS®.

HOF(N) is the default setting that will be used if no HOF command has been issued.

### IDD - Deleting data set name inclusion entries

IDD is used to remove data set name masks previously added by the **IDS** command. If a mask of \*ALL\* is specified then all data set inclusion masks are deactivated.

►► `IDD( mask )` ►◄  
           └───┬───┘  
           All

#### **mask**

Specifies a 1 - 44 character data set name mask. Any wildcard characters in the mask are treated as literals for the purposes of finding the mask to delete.

The following example code deactivates the SYS3.LINKLIB inclusion mask.

```
F HSIJMON,IDD(SYS3.LINKLIB)
```

### IDS - Adding data set name inclusion entries

IDS is used to supply data set name masks, which specify data set names to be excluded from exclusion processing. Program usage data fetched from data sets with names matching inclusion masks, is collected without reference to the data set name mask exclusion list.

Inclusion masks only affect data collection if there are active user-specified exclusion masks. An inclusion mask is normally expected to match a subset of data set names that would match an exclusion mask.

►► `IDS(mask)` ►◄

#### **mask**

Specifies a 1 - 44 character data set name mask. Generic wildcard matching allows a percent sign to match any single character, and an asterisk to match any group of zero or more characters. If the mask contains a slash character (/), the value is processed as a UNIX® path name mask rather than a data set name mask.

You can use the following example code if your intention is to not collect program usage data for data sets with a high-level qualifier of SYS3, except for SYS3.LINKLIB. SYS3.LINKLIB is the only data set with a high-level qualifier of SYS3 for which program usage data is to be collected.

```
XDS(SYS3.*)
IDS(SYS3.LINKLIB)
```

### IMS - Set IMS-managed program usage collection status

Many programs in IMS address spaces are managed by IMS itself rather than by the operating system's program management component. The IMS command provides a system-wide setting to enable or disable the collection of usage of these IMS-managed programs.

►► IMS(  ) ►►

**Y**

Specifies that IMS-managed program usage is to be collected.

**N**

Specifies that IMS-managed program usage is not to be collected.

If no IMS command is issued, then IMS-managed program usage is collected. IMS(Y) is the default setting.

### IPH - Control collection of TCPIP Host details

JIPH is used to control the reporting of the TCPIP host name and IP address. Program usage data sets created by the Usage Monitor will normally have the TCPIP host details present in the header information, but this data can be suppressed by specifying IPH(N).

►► IPH(  ) ►►

**Y**

Specifies that the Usage Monitor will call HSIPHOST to procure TCPIP host details.

**N**

Specifies that the Usage Monitor will not report TCPIP host details in the program usage files.

If no IPH command is issued, the default is IPH(Y).

### JAC - Set job account collection status

JAC is used to specify if the Usage Monitor is to consider the account code of jobs significant when aggregating data. The Usage Monitor normally aggregates data based on the program name, the job name, and the user ID. This setting is used to add the job account, truncated after 20 characters, to the aggregation key.

Do not instruct the Usage Monitor to collect and preserve all job account codes if they are not important to the administration of your system. Collecting and preserving job accounts can significantly increase data volumes.

A change to this setting does not take effect until the next collection repository switch.

►► JAC(  ) ►►

**Y**

Specifies that job account codes are used.

**N**

Specifies that job account codes are ignored.

If no JAC command is issued, then job accounts are used. The default is JAC(N).

**JID - Control the preservation of batch job identifiers**

JID is used to control whether all batch job identifiers are to be preserved or not. Normally usage data for each program is aggregated by job name and user ID, with only the most recent job identifier being retained. JID provides the option of keeping all batch job identifiers so that the number of jobs using a program can be counted, and usage can be attributed to specific individual jobs. Job identifier aggregation for started tasks and TSO user sessions is always equivalent to JID(N) and is not affected by this setting.

►► JID(  ) ►►

**Y**

Specifies that batch job identifiers should not be overlaid and that different batch job identifiers should prevent data aggregation.

**N**

Specifies that normal aggregation by job name and user ID is to proceed without considering job identifier differences.

The default setting of JID(N) applies each time the Usage Monitor is started.

**JNM - Control the collection of job names**

JNM is used to specify whether the Usage Monitor collects the names of jobs which use programs or not. If the names of jobs which use the various programs are not considered to be important, you can dispense with the collection of these names. The advantage of not collecting individual job names is the reduction in processing times and data volumes caused by the aggregation of data into fewer records. When individual job names are not collected, usage is summed over broad address space categories, such as JOB, STC, TSO, and SYS. The total usage counts collected by the Usage Monitor for each program are not affected by this setting.

A change to this setting takes effect at the next collection repository switch.

►► JNM(  ) ►►

**Y**

Specifies that the name of each job running a program is to be collected.

**N**

Specifies that only a broad address space category of each job running a program is to be collected, instead of the individual job name.

If no JNM command has been issued, then job names are collected. JNM(Y) is the default.

### LDD - Deactivate LOAD exclusion entries

LDD is used to deactivate a LOAD exclusion entry previously activated by the LDX command. Names specified as operand values should exactly match names already used in LDX commands.

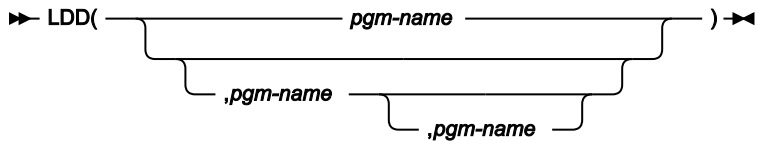

#### *pgm-name*

Specifies a 1 - 8 character program name.

### LDX - Add or activate a LOAD exclusion

The Usage Monitor tracks programs that are given control as well as those that are loaded into storage even if they are not explicitly given control. When these events occur, the programs involved are deemed to be **used**. However, there are some auditing and administration software components which bring modules into storage for the purposes of analysis or extracting product enablement status information. In these cases, it is not helpful to say that the target programs were used.

The LDX command is used to exclude these cases from collected usage data. The relevant program names are supplied as values in LDX commands. The programs named in LDX commands are those programs which perform the analysis or which issue the status request of numerous and perhaps varying subject programs.

Programs which are the subject of LINK or LOAD and DELETE requests issued by a program named in an active LDX setting are excluded from usage data collection.

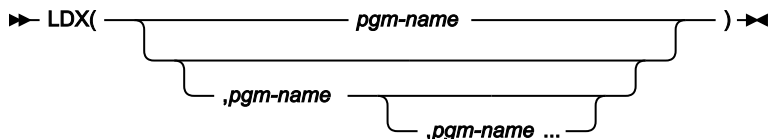

#### *pgm-name*

Specifies a 1 - 8 character program name.

### LNK - Set linklist library collection status

LNK is used to specify whether output data sets written by the writer task will include a list of linklist libraries or not. While program HSIPIINQ will collect linklist library information, it can only report the libraries for the system on which it executes, and it may not always be run on every system where the Usage Monitor is running. Enabling this data collection allows the data base to reflect the correct linklist status of libraries for each system where the Usage Monitor is active.



**Y**

Specifies that linklist library information is to be collected.

**N**

Specifies that linklist library information is not to be collected.

If no LNK command is issued, then linklist library information is collected. LNK(Y) is the default setting.

The LNK setting is only referenced by the writer task at the end of a collection cycle, and the linklist library information collected represents the status at that time.

**LPA - Set link pack area program monitoring status**

LPA is used to specify whether the monitoring of programs in the Link Pack Area (LPA) is to occur or not. All types of LPA are included in this category.



**Y**

Specifies that LPA program usage is to be monitored.

**N**

Specifies that LPA program usage is not to be monitored.

If no LPA command is issued, then LPA program usage data is collected. LPA(Y) is the default setting.

A change to this setting does not take effect until the next collection repository switch.

**LRD - Deactivate a long-running program entry**

LRD is used to deactivate an entry created by a previous LRP command, or an entry created from the system program properties table. Job step programs with names matching inactive entries will not be treated as long-running programs by the Usage Monitor. Names specified as operand values should exactly match names specified either in a previous LRP command or in the system’s program properties table.

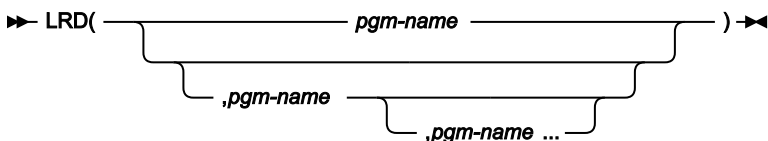

**pgm-name**

Specifies a 1 - 8 character program name.

## LRP – Specify long-running program

LRP is used to inform the Usage Monitor that the named program is to be considered as long-running and that the CPU time for the address space is to be entirely attributed to the named program. While this does mean that CPU time for dynamically invoked programs will not be tracked, it does mean that CPU consumption can be monitored without having to wait until the job step terminates. You can use the LRP(\*DFLT\*) command to undo any LRD and LRP commands that have been processed.

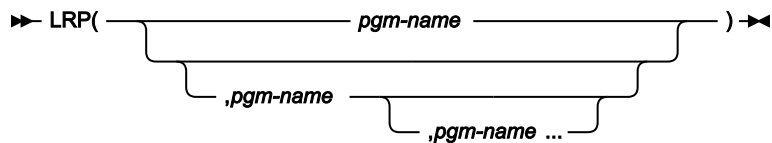

### *pgm-name*

Specifies a 1 - 8 character program name.

The initial list of long-running program names is formed from the system's program properties table active at the time that the Usage Monitor is started.

## MCL – Set the data set SMS management class

The MCL command is used to override the management class that is assigned to dynamically created output data sets by the system's ACS routines. You may use this, for example, to inhibit backing up the data sets, or to assign a relevant space management policy.

►► MCL( *mgmtclas* ) ►►

### *mgmtclas*

Specifies a 1 - 8 SMS management class name.

## PAK – Set the zip compaction level

The PAK command is used to set the level of zip compaction that the writer task will use when writing to the dynamically created output data sets. The level is specified as a single decimal digit in the 0 to 9 range. Level 0 specifies that the zip **shrink** method is used. Levels 1 to 9 specify that the corresponding compaction level of the **deflate** method is used. The default is 1 which is the fastest **deflate** compaction level.

Larger PAK values will increase data compression but will also consume disproportionately more CPU time.

►► PAK(*n*) ►►

### *n*

specifies a single decimal digit from 0 to 9.

If no PAK command is issued then PAK(1) will be used, resulting in a fast **deflate** zip file.

**PLN - Set the sysplex name**

PLN is used to override the name of the sysplex contained in the output header record. The actual sysplex name is used as a norm, but an override allows control over which systems have their inventory updated when the PLX=Y Inquisitor setting is used. The value specified here should match the PLEXNAME= value specified for the corresponding Inquisitor scans. Overriding the sysplex name is not usually needed unless PLX=Y is used and the sysplex grouping does not match the shared DASD grouping. Symbols can be employed in the construction of the sysplex name. Available symbols include all z/OS® system symbols, &SMF, the SMF identifier for the system, and &SYSLPAR, the logical partition name for the system.

▶▶ PLN(plexname) ◀◀

**plexname**

Specifies a string which is to be resolved to an identifier 1-8 bytes in length.

**PRE - Collect usage for long running programs**

PRE is used to specify if the Usage Monitor is to collect usage for programs which started before the current collection cycle. Without this data collection a Usage Monitor collection cycle will have no usage data for programs which started running before the cycle started and remain running when the cycle ends. If a job or task runs for more than two days, most days will not have any usage recorded for the main program unless this additional data collection is enabled.

When the additional data collection is enabled, previously fetched programs resident in the regions of started task and batch job address spaces where SMF interval recording is active have usage recorded in each collection cycle which encompassed the end of at least one SMF interval.

This setting can affect usage figures. For example, the main program of a constantly running task can accrue a usage count of around 30 over a month even though it was really only used once for an extended period.

▶▶ PRE(  ) ◀◀

**Y**

Specifies that usage for previously running programs is to be collected.

**N**

Specifies that usage for previously running programs is not to be collected.

The default setting of PRE (Y) applies each time the Usage Monitor is started.

**PRI - Set the data set space primary allocation**

PRI is used to specify the primary space allocation quantity in tracks. It is used for output data set allocations.

▶▶ PRI(*trks*) ◀◀

**trks**

Specifies a number of tracks from 0 to 150,000.

If no PRI command is issued, the primary space allocation is 750 tracks. The Usage Monitor uses the RLSE space allocation attribute.

The following example code sets the primary space allocation to 900 tracks.

```
F HSIJMON,PRI(900)
```

**PRS - Set registered software activity data collection status**

PRS is used to specify if the Usage Monitor is to output records containing information about the activity of registered software. Registered software uses the system Register service. The data contains information about the usage of registered software, and information about software registration settings from the PARMLIB member IFAPRDxx.

A change to this setting does not take effect until the next collection repository switch.

► PRS(  ) ►

**Y**

Specifies that registered software information is collected and output.

**N**

Specifies that registered software information is neither collected or output.

If no PRS command is issued, then registered software data is collected. PRS(Y) is the default.

**QSZ - Specify collection element queue area size**

QSZ is used to specify the virtual storage size of the SCOPE=COMMON memory object which forms the area where collected usage data is queued to the Usage Monitor address space for storing into the collection repository. The QSZ value specifies the number of storage segments the area occupies, where a segment is one megabyte in size.

The QSZ value used is fixed for the life of the Usage Monitor address space. To change the QSZ value the Usage Monitor started task must be recycled.

► QSZ( *segments* ) ►

**segments**

Specifies a number of segments from 1 to 200.

If no QSZ command is issued, a 10MB queue area will be used. The queue area is processed as a LIFO stack, which means that only the necessary number of pages needed to hold the peak queue length will need to be backed by physical storage, no matter how large the QSZ value is set.

## REF - Refresh Usage Monitor settings

REF is used at any time to reset Usage Monitor settings according to commands in the HSIZIN file, without stopping and starting the Usage Monitor. The detailed results of the refresh operation are written to the HSIZMSG file.

The processes of a refresh operation include:

- Verify that HSIZIN is still allocated.
- Open HSIZIN.
- Set the program exclusion list to the default list.
- Deactivate all data set exclusion list elements.
- Deactivate all data set inclusion list elements.
- Process the commands in HSIZIN.
- Close HSIZIN.
- Issue either [HSIZ059I on page 363](#) or [HSIZ060I on page 363](#), as appropriate.

### ►► REF ◄◄

The following example code changes Usage Monitor settings to updated values from HSIZIN.

```
F HSIJMON,REF
```

## SCL – Set the data set SMS storage class

The SCL command is used to override the storage class that is assigned to dynamically created output data sets by the system's ACS routines.

### ►► SCL( *storclas* ) ◄◄

#### *storclas*

specifies a 1 – 8 character SMS storage class name.

## SEC - Set the data set space secondary allocation

SEC is used to specify the secondary space allocation quantity in tracks. It is used for output data set allocations.

### ►► SEC( *trks* ) ◄◄

#### *trks*

Specifies a number of tracks from 0 to 150,000.

If no SEC command is issued, the secondary space allocation is 300 tracks. The Usage Monitor uses the RLSE space allocation attribute.

The following example code sets the secondary space allocation to 600 tracks.

```
F HSIJMON,SEC(600)
```

## SID - Set the Usage Monitor system identifier

SID is used to override the system identifier contained in the output header record. The SMF system identifier is used as a norm, but an override enables the data from separate systems to be differentiated in all instances where duplicate SMF identifiers are in use. Symbols can be employed in the construction of the system identifier. Available symbols include all z/OS® system symbols, &SMF, the SMF identifier for the system, and &SYSLPAR, the logical partition name for the system.

►► SID(*sid*) ◄◄

*sid*

Specifies a string which is to be resolved to an identifier 1-4 bytes in length.

**Table 16. Examples of using the SID command**

Command purpose	Example code
Set the output system identifier to PROD.	F HSIJMON,SID(PROD)
Set the header record system identifier to the current LPAR name. The LPAR name must not exceed four characters in length.	F HSIJMON,SID(&SYSLPAR)

## SIZ - Set the data space repository size

SIZ is used to specify the maximum number of entries that the collection repository can hold.

►► SIZ(*entries*) ◄◄

*entries*

Specifies a number of entries from 100 to 6,000,000.

If no SIZ command is issued, a data space capacity of 200,000 entries is used. Each entry occupies 232 bytes and contains a pointer to a separate part of the repository dedicated to holding data set and UNIX® file names. Storage is conserved by only storing a single copy of each collected data set and UNIX® file name. As each repository page has data placed in it for the first time, that page must be backed physically by the system. When a collection repository is full, a repository switch is triggered automatically. A repository switch also occurs when data stamped after the switch time is detected, or when a manual switch is requested by the **SWI** command.

The following example code sets the size of future collection repositories to 1,000,000 entries.

```
F HSIJMON,SIZ(1000000)
```

## SJS - Controlling spawned job suffix preservation

When a spawned address space is created by a unit of work with a job name that is shorter than eight characters, the system appends a sequence digit in the 1 to 9 range to the job name, and this becomes the job name of the spawned address space. This approach means that the usage of programs generated by jobs with a specific name can be logged under as many as ten different job names. The system-generated job names usually do not assist in identifying the source of the work because there is often no other reconciliation data which also uses these generated names.

The SJS setting can be used to remove the spawned sequence number suffix so that all usage events for programs are logged under the original job name, resulting in fewer Usage Monitor records and reduced processing time. If the spawning job name is eight characters long and ends in a digit in the 1 to 9 range, then activity in spawned address spaces (but not the original address space) can be reported under a job name which is only the first seven characters of the original job name. If this is likely to present a problem then use SJS(N).

► SJS(  ) ◄

**Y**

Spawned job name suffix digit is truncated.

**N**

No editing is performed of spawned address space job names.

SJS(Y) is the default if no SJS command has been issued since the Usage Monitor started.

## SWI - Switch to a new collection repository

SWI causes a new collection repository to be created and used for subsequent data collection. A writer task processes the data contents of the repository that is being used at the time that the SWI command is issued.

The SWI command has no operands. It is invalid in the HSIJIN initial command file. As well as the switch caused by an explicit SWI command, automatic switches occur when a repository becomes full, and when data stamped after the switch time is detected. The SWI command might be rejected if the writer task is busy.

► SWI ◄

The following example code manually switches to a new repository.

```
F HSIJMON,SWI
```

## TMP - Set temporary data set collection status

TMP is used to specify how program libraries with system generated names are to be processed. Normally the Usage Monitor discards information about programs fetched from temporary data sets since the library will no longer exist after the job ends and so will not form part of the persisting software inventory. However, if you wish to collect usage data from programs residing in temporary data sets then you can set TMP(Y).

►► **TMP**(  ) ►►

**Y**

Specifies that usage containing temporary data set names is collected.

**N**

Specifies that usage containing temporary data set names is discarded.

If no TMP command is issued, then program usage events pertaining to temporary data sets are discarded. TMP(N) is the default setting.

### UID - Control the collection of user details

UID is used to specify whether the Usage Monitor collects the identifiers and names of users who use programs or not. If the details of users who use the various programs are not considered to be important, then you can dispense with the collection of this information. The advantage of not collecting user information is the reduction in processing times and data volumes.

When user information is not collected, the user ID data item remains blank, and user names are not output, regardless which UNM setting is current. The total usage counts collected by the Usage Monitor for each program are not affected by this setting.

If you want program usage attributed to individual users but do not want the names of users to be retained, use UID(Y) and UNM(N).

A change to this setting does not take effect until the next collection repository switch.

►► **UID**(  ) ►►

**Y**

Specifies that details of each user using a program are to be collected.

**N**

Specifies that details of each user using a program are not to be collected.

If no UID command is issued, user details are collected. UID(Y) is the default.

### UNK - Set the unknown event collection switch

UNK is used to specify whether events with incomplete data are to be collected or not. The database content is not affected. Collecting extra data is useful in determining why some usage events are not captured. It must be set only when requested by IBM support.

►► **UNK**(  ) ►►

**Y**

Specifies that the "unknown" events are to be collected.

**N**

Specifies that the "unknown" events are not to be collected.

If no UNK command is issued, the unknown events are not collected. UNK(N) is the default setting.

A change to this setting does not take effect until the next collection repository switch.

**UNM - Set user name collection status**

Software security packages, such as RACF®, have a name field for each user ID defined to the system. The Usage Monitor collects the user ID (up to eight characters long), and the contents of the name field (up to 20 characters long), as part of the data collection performed when programs are used. UNM is used to specify whether the names of users collected from the security package are output. The output of the user ID is controlled by the **UID** setting. This setting is checked by the writer task when the data in a collection repository is being processed for output.

►► UNM(  ) ►►

**Y**

Specifies that collected user names are written to the output file.

**N**

Specifies that collected user names are discarded.

If no UNM command is issued, then user names are collected. UNM(Y) is the default.

A change to this setting does not take effect until the next collection repository switch.

**UNT - Set the data set allocation unit**

UNT is used to specify the allocation unit to be used for output data set allocations.

►► UNT( *unitname* ) ►►

***Unitname***

Specifies a 1 - 8 character long unit name.

If no UNT command is issued, SYSALLDA is used.

The following example code sets the allocation unit to WORKDA.

```
F HSIJMON,UNT(WORKDA)
```

## USS - Set UNIX® program monitoring status

USS is used to determine if the programs retrieved from Hierarchical File System (HFS) files are to be monitored.

►► USS(  ) ►►

**Y**

Programs fetched from HFS files are to be monitored.

**N**

Programs fetched from HFS files are not to be monitored.

If no USS command is issued, the programs retrieved from HFS files are not monitored. USS(N) is the default setting.

A change to this setting does not take effect until the next collection repository switch.

## VOL - Set the data set allocation volume

VOL is used to specify the allocation volume to be used for output data set allocations. The explicit nomination of a specific volume is necessary when there are no PUBLIC or STORAGE volumes in the allocation unit pool.

►► VOL( *volume* ) ►►

***volume***

specifies a 1 - 6 character long volume serial number.

If no VOL command is issued, a specific volume is not explicitly requested. You must then have PUBLIC or STORAGE volumes in the public allocation pool, unless the data sets are managed by SMS.

The following example code sets the allocation volume to SCR001.

```
F HSIJMON,VOL(SCR001)
```

## WRT - Set the automatic switch-and-write time of day

WRT is used to specify a time-of-day to end data collection for the current collection repository, and automatically switch to a new one. The data write-out for the closed repository is also initiated at the same time. These events are triggered when data from after the specified time is detected.

The UTC or GMT switch time is calculated using the local time when the repository is created. The time that a data space is terminated is set when it is created. Changes to the system local time offset, such as those caused by a change to daylight saving time status, do not alter the UTC or GMT time that the current repository is closed. The time of the switch, after the next switch, is calculated using the new local time.

►► WRT( *hhmm* ) ►►

**hhmm**

Specifies a 24-hour time-of-day in hour and minute notation. The value must be four decimal digits. The first two digits (hh) must be in the 00 - 23 range. The last two digits (mm) must be in the 00 - 59 range.

If no WRT command is issued, the automatic switch time of midnight is used. That is, WRT(0000) is the default.

The following example code sets the automatic switch-and-write time to 10 minutes before midnight.

```
F HSIJMON,WRT(2350)
```

**XDD - Deleting data set name exclusion entries**

XDD is used to remove data set name masks which were added by the XDS command. XDD can also deactivate entries from the default exclusion list that was automatically created by the Usage Monitor.

If a mask of \*ALL\* is specified then all (both default and user) data set exclusion masks are deactivated.

```
► XDD( mask ) ►
      *ALL*
```

**mask**

Specifies a 1 - 44 character data set name mask. Any wildcard characters in the mask are treated as literals for the purposes of finding the mask to delete.

The following example code deactivates the SYS3.\* exclusion mask.

```
F HSIJMON,XDD(SYS3.*)
```

**XDS - Adding data set name exclusion entries**

XDS is used to supply data set name masks which specify data set names to be excluded from data collection. Program usage data for programs fetched from data sets with names matching exclusion masks is discarded. When the captured data set name has been matched to an inclusion mask set by the IDS command, the data is collected without reference to the user-defined exclusion mask list. Usage data matching active default data set exclusion masks is discarded before inclusion masks created by IDS commands are examined. Any inactive default exclusion masks can be reactivated by the XDS(\*DFLT\*) command which does not affect user-specified data set filtering.

```
► XDS( mask ) ►
      *DFLT*
```

**mask**

Specifies a 1 - 44 character data set name mask. Generic wildcard matching allows a percent sign to match any single character, and an asterisk to match any group of zero or more characters. If the mask contains a slash character (/), the value is considered to be processed as a UNIX path name mask rather than a data set name mask.

The following example code excludes program usage data from collection for programs fetched from data sets with a high-level qualifier of SYS3.

```
F HSIJMON,XDS(SYS3.*)
```

## ZIP - Set the compressed output data switch

ZIP is used to control whether the writer task is to compress output data or not. Compressing the output data reduces data volume, in turn reducing data transfer time and storage space requirements.

► ZIP(  ) ►

### Y

Specifies that output data is to be compressed.

### N

Specifies that output data is not to be compressed.

If no ZIP command is issued, then compressed data is output. ZIP(Y) is the default setting.

If abend S213-C8 occurs when the writer task opens the output data set, **ZIP(N)** will be issued internally and the data will be written without being zipped. In this case, the following WTO message will be issued:

```
HSIZ033I UMON-WTR ZIP(N) COMMAND PROCESSED
```

## Monitoring usage in CICS® regions

The CICS® Transaction Server for z/OS® performs much of its program management outside of the contents supervisor framework that most applications use. For the Usage Monitor to accurately detect and record the use of programs in a CICS® region, you must customize each CICS® region where you require detailed program usage monitoring.

To prepare a CICS® region to enable detailed monitoring, you must install the following components:

- CICS® global user exist (GLUE) programs
- An enabling program to activate these user exit programs
- An entry in the program list table (PLT) that triggers the enabling program

The customized JCLLIB library contains the following sample jobs that you can copy and use in your customization:

- The HSISENAX member contains a sample job to translate, assemble and bind the enabling program.
- The HSISPLTX member contains a sample job to create a PLT with the required entry to trigger the enabling program.  
If you use this sample job, verify the name of the enabling program and the PLT suffix before you submit the job.

The CICS® program monitoring facility does not support releases earlier than CICS® Transaction Server version 5, release 1. Different releases of the CICS® Transaction Server require different versions of the GLUE programs. You must ensure that the correct version of these programs is used for each CICS® region. You must also take care when upgrading regions to a later release of CICS® so that the correct version of this module will be used with the newer software.

Installed GLUE modules from older releases of the Usage Monitor will not collect any data for this release of the Usage Monitor. The GLUE modules in this release of the Usage Monitor cannot collect any data for older releases of the Usage Monitor.

The following table lists the required GLUE programs for different versions of the CICS® Transaction Server:

**Table 17.**

CICS® Transaction Server release	Usage Monitor GLUE modules
Version 5, releases 1, 2 and 3	HSIZFTC3, HSIZEI13
Version 5, releases 4, 5 and 6	HSIZFTC4, HSIZEI14

When you implement this CICS® Transaction Server customization, the Usage Monitor can collect and record data related to program name and data set name. The collected data is subject to the Usage Monitor program name and data set name selection and exclusion filters. You can stop data collections from all HSIZFTCx and HSIZEI1x GLUE programs with the CIC(N) Usage Monitor setting. CIC(Y) is the default setting if you do not issue a CIC Usage Monitor command.

Depending upon the level of program usage detail you require, the HSIZFTCx exit might produce sufficient data for your needs, without the HSIZEI1x exit. If you want to access more detailed CICS® data, such as particulars of transactions and the end users involved, a specialized CICS® monitor such as IBM® OMEGAMON® for CICS® on z/OS® is required.

## Customizing a CICS region to provide usage data

### Procedure

1. Copy the appropriate HSIZFTCx and HSIZEI1x global user exit (GLUE) programs from the SHSIMOD1 library to a DFHRPL library of the CICS region.
2. Customize and submit the HSISENAX job to create a program that enables the HSIZFTCx and HSIZEI1x exit programs:
  - a. Customize the sample job for translating, assembling, and binding the enabling program that is provided in the HSISENAX member in the customized JCLLIB library.  
For convenience, you can name this program HSISENAX, where x is the same suffix character as the suffix of the HSIZFTCx and HSIZEI1x programs that it enables.
  - b. Check that the name specified in the PROGRAM operand of EXEC CICS ENABLE statement is the name of the enabling program.
  - c. Check that the name specified in EXEC CICS ENABLE PROGRAM statement is the name of the of the GLUE programs.
  - d. Link the HSISENAX enabling program into the same DFHRPL library where you copied the HSIZFTCx and HSIZEI1x GLUE programs.
  - e. Submit the HSISENAX job.

3. Add an entry in the following format to the active program library table (PLT) of the CICS Transaction Server to install the HSIZE<sub>N</sub>A<sub>x</sub> module:

```
DFHPLT TYPE=ENTRY,PROGRAM=HSIZENA
```

Place the entry before the `DFHPLT TYPE=ENTRY,PROGRAM=DFHDELIM` entry to load it early during CICS initialization and minimize the need for program resource definitions.

4. Ensure that the PLTPI setting for the CICS region specifies your newly updated PLT.
5. Optional: Use the HSITAGP tagger program to tag non-vendor application programs that you want to be identified in usage reports.

## Results

When you complete this task, the use of programs that are given control by various mechanisms in the CICS Transaction Server are attributed to the CICS region address spaces that invoke them.

## What to do next

You can stop data collection from all HSIZE<sub>FTC</sub><sub>x</sub> and HSIZE<sub>II</sub><sub>x</sub> glue programs with the CIC(N) Usage Monitor setting. The CIC(Y) option is the default if you do not issue a CIC Usage Monitor command.

## Importing Inquisitor data

The Inquisitor Import reads data from Inquisitor scans, where the data is filtered and matched to products. The filtered, matched data is then copied to the Repository tables where it can be viewed and queried by the Analyzer reporting utility.

---

Related information

[PLX parameter of the Inquisitor program on page 62](#)

[Collecting scanned libraries with the Inquisitor for z/OS on page 61](#)

## Running the Inquisitor Import

The HSISIQIM job in the JCLLIB library performs the Inquisitor Import. This job is generated from the HSISCUST post-installation customization job.

## About this task

Run-time for the HSISIQIM job depends on the number of modules to be imported into the database Inquisitor tables. Because the processing is memory-intensive, run the HSISIQIM job during off-peak periods.

If the HSISIQIM job processes the same data that is generated by the Inquisitor scan for a specified system, the job terminates with an error to indicate that the input file is a duplicate input file.

## Procedure

1. In the HSIQIM job, update the following parameters, according to your requirements:

- **FULLREMATCH**: Set to N (no) to skip import from scanned libraries where no member directories have changed since a previous Inquisitor Import to the same Repository. Set to Y (yes) to import and match process all libraries.

When **FULLREMATCH** is set to Y, an extra check is performed on libraries in the repository. For a given system ID (SID), existing libraries in the repository are marked as deleted unless the libraries are found in the scanned Inquisitor file. For shared libraries (where PLX=Y), the scanned Inquisitor file can be from any SID that belongs to the sysplex. For non-shared libraries (where PLX=N), the scanned Inquisitor file must be from the same SID. The deletions include products, libraries and modules.

- **PRODUCTONLY**: Set to N (no) to import all modules, including unidentified modules. Set to Y (yes) to import only matched modules.

The settings for both of these parameters influence the duration of the import process.

2. Review and modify other parameters, as required, in the PARMLIB member.
3. Submit the HSIQIM job.

## Import filters and matching

When you import data collected by the Inquisitor, the import procedure reads the data and filters and matches the data before copying the data to the Repository tables.

The Inquisitor Import loads data and performs the following tasks:

1. Reads Inquisitor data generated from Inquisitor scans. To exclude importing specific libraries, the Inquisitor data is filtered against a set of supplied Inquisitor filter tables. These Inquisitor filter tables are updated monthly, together with the knowledge databases. The filtering excludes, for example, the ISV distribution libraries.
2. Matches load modules to best fitting products at the version, release, and modification (VRM) level. Best matches for modules are found based on module names and sizes, and information in the Global Knowledge Base (GKB) and Local Knowledge Base (LKB). Temporary scorecard tables are used to hold all the possible scorecards for modules in a given library while they are matched.
3. Loads matched load modules, including matching information, into the Repository tables. Data from the Repository tables are now ready for viewing or reporting using the Analyzer reporting facility.
4. Aggregates usage data for rediscovered modules in the Repository tables.

The Inquisitor Import uses memory intensively in order to efficiently match many Knowledge Base scorecards to library modules. The maximum memory requirements depend on the number of modules in a library of an Inquisitor Import file, and the number of scorecards in the GKB and LKB that affect the processed libraries. To estimate a requirement, allow 5M +1.5k per module. For example, for an Inquisitor file containing a maximum library size of 30000 modules, the requirement is approximately  $5M + (0.0015 \times 30000) = 50M$ .

## TPARAM parameters

The TPARAM parameters that you specify for Inquisitor Import define what data is included in the import.

**COMMIT=**

Default is 1000. Number of records stored before issuing a COMMIT.

**COUNTUSAGE=**

The parameter controls when product usage totals are counted. Setting to Y indicates that records are counted in the Inquisitor Import job for modules that have usage and are identified for the first time when usage records were imported before discovery was performed. These recounts of product usage because of modules that are identified can be time consuming.

The Inquisitor Import deletes count entries for products for which at least one module is identified for the first time, and that have usage details as these counts are invalidated by the identification. This is done regardless of the setting of the COUNTUSAGE parameter.

Default setting is COUNTUSAGE=N. For performance reasons, if you are running Inquisitor Imports for many systems importing IQ data into the same Repository, run the Aggregator step only once in the last IQ Import job. The Aggregator step performs the same function in summarizing the product usage records.

**DSN=**

Db2® location. Value assigned, as defined in job HSISCUST

**FILTERSCHEMA=**

Inquisitor Import filter qualifier. Name of qualifier is &GKBZSCHM\_IQF7

**FULLREMATCH=**

Default is N, which means all libraries are imported and processed. N means to skip import from scanned libraries where no member directories have changed since a previous Inquisitor Import to the same Repository.

**GKBSCHEMA=**

Global Knowledge Base qualifier for z/OS®. Name of qualifier is &GKBZSCHM\_GKB7

**GKUSCHEMA=**

Global Knowledge Base qualifier for z/OS® UNIX™. Name of qualifier is &GKBZSCHM\_GKU7

**LKBSCHEMA=**

Local Knowledge Base qualifier for z/OS®. Name of qualifier is &REPZSCHM\_LKB7

**LKUSCHEMA=**

Local Knowledge Base qualifier for z/OS® UNIX™. Name of qualifier is &REPZSCHM\_LKU7

**PRODUCTONLY=**

Default is N, which means all modules, including unidentified modules, are loaded into the Repository. Y means only modules that have been matched to known products are loaded into the Repository, meaning, application modules are excluded.

**REPSCHEMA=**

Repository qualifier. Name of qualifier is &REPZSCHM.

## Importing usage data

The Usage import job imports data generated by the Usage Monitor and aggregates usage data for discovered or identified modules in the Repository tables in the database.

The HSISUIMP job in the JCLLIB library performs the Usage import. This job is generated from the HSISCUST post-installation customization job. Because run-time for this job depends on the volume of usage data to load, run this job during off-peak periods.

Usage data files can be either outputs from the Usage Monitor or condensed outputs from the ZCAT utility. These output files can be concatenated as a single input in the job. When you are priming a new repository, use a single small file as input when loading usage data for the first time.

If the HSISUIMP job processes the same data that is generated by the Usage Monitor for a specified system, the job terminates with an error to indicate that the input file is a duplicate input file.

---

Related information

[Collecting usage data with the Usage Monitor on page 88](#)

## TPARAM parameters

The TPARAM parameters that you specify for Usage Import define what data is included in the import.

### **CHECKPERIOD=**

Default is 12. The number of months prior to the current month for which records in TUSEMTD are still retained.

### **COMMIT=**

Default is 1000. Number of records stored before issuing a COMMIT.

### **COUNTUSAGE=**

The parameter controls when product usage totals are counted. Setting to Y indicates that records are counted in the Usage Import job for systems and periods that are processed and receive new usage details.

The Usage Import deletes count entries for systems and periods that receive new usage details and are invalidated by the new details, regardless of the setting of the COUNTUSAGE parameter.

Default setting is COUNTUSAGE=N. For performance reasons, if you are running Usage Imports for many systems importing usage data into the same Repository, run the Aggregator step only once in the last Usage Import job. The Aggregator step performs the same function in summarizing the product usage records.

**DSN=**

Db2® location. Value assigned, as defined in job HSISCUST.

**GKBSHEMA=**

Global Knowledge Base qualifier for z/OS®. Name of qualifier is &GKBZSCHM\_GKB7.

**REPSHEMA=**

Repository qualifier. Name of qualifier is &REPZSCHM.

## Aggregating usage and discovery data

The Aggregator is a program that populates the Asset tables.

An audit table captures information of the Aggregator when this program is run, and these audit records can be browsed using an Analyzer report. As part of housekeeping, obsolete audit records from this program are deleted by the MDEL Deletion utility, together with audit records from other utilities.

These tables are accessed by Analyzer reports and batch jobs, and offer a higher level view of product discovery and usage at a version rather than a release or module level. The Aggregator also calculates product discovery and usage count totals that are used to speed up the Analyzer queries.

The Aggregator should be run as the final job in a batch run of Inquisitor Import and Usage Import jobs, and before the repository is accessed by the Analyzer. This ensures that asset reports and counts are synchronized with the latest collected discovery and usage details.

It is usual for asset level usage details to be kept longer than module usage details. This is controlled by the KEEPAGGR parameter of the Usage Deletion program, which has a longer default period than the KEEPDETAIL parameter. The aggregated entries are normally kept for the longer KEEPAGGR period and are usually only recalculated for periods where module usage details are available.

The Aggregator run can be time consuming since it is run for the entire repository and periods rather than an individual SID (as in the case of the Inquisitor Import), or system and period (as in the case of the Usage Import). It is therefore more efficient to run the Aggregator only once following several imports of usage or discovery data. Ensure also that you do not keep usage details for longer than is necessary for your site, and that Usage Deletion is run on a regular basis.

An example of how to run the Aggregator can be seen in sample jobs that are generated by HSISCUST, such as HSISIQIM (Inquisitor Import) and HSISUIMP (Usage Import).

## TPARAM parameters

The TPARAM parameters that you specify for aggregating usage and discovery data is included in the import.

**COMMIT=**

Default is 1000. Number of records stored before issuing a COMMIT.

**COUNTUSAGEFULL=**

Default value is N, and this means that only entries for systems and periods that are affected by recent activities are calculated. This parameter performs the same function as the COUNTUSAGE parameter, as described in sections - [Importing Inquisitor data on page 121](#), and [Importing usage data. on page 123](#)

A value of Y means that usage count totals for all systems and periods are deleted and recalculated.

It is more reliable, however, to recalculate all totals preferably with every run of the Aggregator, or at least occasionally if the COUNTUSAGEFULL=Y process is too time consuming. The time taken to refresh the usage counts can be seen in the Aggregator log.

**DSN=**

Db2® location. Value assigned, as defined in job HSISCUST.

**IXBUFFERPOOL=**

The buffer pool for indexes created on declared global temporary tables that are used by the Aggregator. If not supplied, the buffer pool defined for the database where the global temporary tables belong is used. This value is normally only needed by sites which have a requirement to specify different buffer pool values for different applications or invocations, and have used specific values during the creation of the database repository.

**IXSTOGROUP=**

The storage group for indexes created on declared global temporary tables that are used the Aggregator. Default is SGHSIIDX. This value need only be specified by sites that have a procedural requirement of not using the default Db2® storage group value, and have used a different STOGROUP value during the creation of the product database repository.

**GKBSHEMA=**

Global Knowledge Base qualifier for z/OS®. Name of qualifier is &GKBZSCHM\_GKB7.

**REPSHEMA=**

Repository qualifier. Name of qualifier is &REPZSCHM.

## Activating the Automation Server

The Automation Server discovers new data sets and processes them by starting a set of predefined actions that associate the data with data set name masks that form a catalog search. This search determines if any data set names matching the mask are to be processed.

### Automation Server overview

The Automation Server provides the ability to select data sets if you have data set names that are variable, such as those created by the Usage Monitor, which have low-level qualifiers containing time stamps.

The Automation Server runs as a started task in its own address space.

The user ID for the Automation Server must have an OMVS segment and a UID, or there must be a default UID configured.

The Automation Server issues a system-wide ENQ to ensure that there is only one instance of it in a z/OS® image. A single instance of the Automation Server continuously references all data sets, catalogs, and volumes that are accessible from all systems in a sysplex so it is unnecessary for the Automation Server to run on more than one system.

Usually a single instance of the Automation Server is sufficient to handle the work from multiple systems which share the same DASD. JOB actions can have any necessary system affinities coded in their JCL.

Input control statements define the processing to be performed by the Automation Server. There are two types of control statements, *action* statements and *DSN* statements:

#### **action**

Action statements name the template member which forms the basic input for the action to be performed when a relevant data set is newly discovered by a catalog search. They have optional operands to specify time-of-day, day-of-week, day-of-month, and month-of-year restrictions.

#### **DSN**

DSN statements provide a data set name mask to be associated with the preceding action statement. There can be many DSN statements after each action statement.

There are currently two types of action statement:

#### **FTP**

Starts the FTP utility to perform a file transfer.

For the FTP action, the template member is read and, after symbol substitution processing, is written to the file defined by the INPUT DD statement. The INPUT file is allocated to a temporary data set. The FTP program is attached as a subtask and scans the INPUT file to process the FTP requests. The report messages it generates are written to the OUTPUT file.

Upon completion of the FTP subtask, the Automation Server examines the completion code. If the program ends normally with a zero return code, the Automation Server deems the action to have been successful and updates the action status in the HSIACDS file so the action is not repeated for this data set.

If the FTP program abends, the Automation Server deems the action to have failed. A failed transfer is tried again at a later time. A retry is subject to specified scheduling constraints. The OUTPUT FTP report file contains information to track the exact cause of a transfer failure.

#### **JOB**

Submits a batch job.

For the JOB action, the template member is read and, after symbol substitution processing, is written to the file defined by the INTRDR DD statement. This file is directed to the internal reader used by the system, and the jobs submitted by the Automation Server become available for JCL conversion as soon as the INTRDR file is closed, or another JOB card image is found by the reader.

The Automation Server deems all JOB submissions successful, so there are no retries. Any failure should be investigated using the appropriate procedures used by your installation.



**Note:** The job stream in a JOB action template member may define more than one job.

The Automation Server does not check template member records for either FTP or JCL validity.

Before initiating an action for a detected data set, the Automation Server attempts to exclusively allocate the data set. If the data set is in use, the action is not performed and the awaiting retry status is stored in the control data set. The action is performed when the data set is next found to be available for use within any specified scheduling restrictions. Dynamic allocation failures due to other reasons do not inhibit the action.

## Running the Automation Server

To run the Automation Server, you must create a control data set, configure the Automation Server as a started task, design request control statements, and exclude data sets from processing.

## Creating the Automation Server control data set

To create the Automation Server control data set, use member HSIASALC in the JCLLIB. This member is generated from the HSISCUST post-installation customization job.

### Procedure

1. Allocate sufficient space for the Automation Server to handle the workload required by the installation.
  - One 96 byte record (including the 52-byte key) is required for each data set processed by the Automation Server.
2. Create the control data set by running the HSIASALC job that contains the IDCAMS JCL and control statements.
3. In the HSIACDS ddname, allocate the VSAM KSDS control data set to the Automation Server.

## Copying the started JCL task to a library

The Automation Server is run by the HSIJAUTO member in the JCLLIB library that is supplied in the SHSIPROC data set. To start the HSIJAUTO member as a started task, you must customize the JCLLIB member and copy it to an authorized PROCLIB library.

### Procedure

1. Set values for the following parameters in the HSIJAUTO task in the JCLLIB library:
  - HSI : Set high-level qualifiers for the installation target libraries months
  - HSIINST: Set high-level qualifiers for the &HSIINST.PARMLIB data set created by the HSISCUST job.
  - ACDS: Set the data set name of the Automation Control Data Set (ACDS).
2. Copy the HSIJAUTO member from the JCLLIB library to an authorized PROCLIB library.

## Files used by the Automation Server

Several files must be available for use by the Automation Server.

**STEPLIB**

Load library containing the product software. Not required if IBM Z Software Asset Management is installed into the system link list.

**HSIACNTL**

Partitioned data set containing fixed-length 80-byte records. Member HSIAPARM of this partitioned data set contains the Automation Server control statements that specify the actions to be performed. For each action in the HSIAPARM member, there is a corresponding member of the same name containing the template data for that action. The template data is made up of JCL or an FTP command stream containing symbolic references, to be resolved by the Automation Server when the action is performed.

**HSIACDS**

A VSAM KSDS control data set used by the Automation Server.

**HSIAMSG**

Specifies the message report file for the Automation Server. Initialization statements, error messages, and activity logging messages, are written to this file.

**SYSPRINT**

Specifies the message report file for Language Environment®.

**SYSOUT**

Specifies the message report file for Language Environment®.

**OUTPUT**

Specifies the message report file for the FTP program. The contents are determined by the FTP program installed in the system.

**INPUT**

Specifies a fixed length 120-byte record file containing FTP commands read by the FTP program. The FTP commands are written to this file before the Automation Server FTP action is performed.

**INTRDR**

Specifies a fixed length 80-byte record file to be directed to the internal reader used by the system. The Automation Server writes a job stream to this file whenever a JOB action is to be performed.

## Designing request control statements

Automation Server action requests are specified in the HSIAPARM member of the SHSIAPARM file.

### Syntax rules

Syntax rules are as follows:

- Records with an asterisk in column 1 are comments.
- Blank records are comments.

- A parameter record has one or more parameters, each with a value specified within parentheses after the parameter name.
- The first parameter specifies the statement type.
- All parameters must begin before column 72.
- Blanks can be used before and after parameter names, parentheses, and parameter values.
- Continuations on to subsequent records are not possible.

## Statement syntax

### Action statement

Each statement requests that an action is performed for a data set when it matches an associated data set name mask, and is detected for the first time. An action is performed once for each match, but the presence of a data set triggers the action for each specified data set name mask it matches.

Action statements have several optional operands to provide control over when Automation Server processing is to occur.

These operands can specify:

- time-of-day window
- day-of-week control string
- day-of-month window
- month-of-year control string

When all these constraints have been satisfied, the Automation Server searches the catalog for data sets with names that match the masks associated with an action.

### Data set name mask statement

Each data set name mask statement associates the specified data set name mask with the preceding action statement. It is invalid for the HSIAPARM member to begin with a data set name mask statement. When a data set with a name matching the specified mask is first located, the action specified in the preceding action statement is triggered.

The data set name mask of NULLFILE is an exception. When a data set name mask with this exact value is processed by the Automation Server, a catalog search is not performed, but the associated action is triggered as if a new cataloged data set matching the mask has been located. Automation Server symbols for the data set name, and for the first qualifier of the data set name have values of the 8-byte string NULLFILE. Use the data set name mask of NULLFILE to trigger scheduled actions which do not depend on the creation of a particular data set.

Figure 5. Action statement syntax

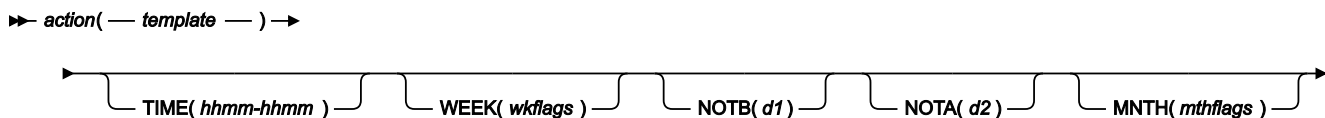

**action**

FTP or JOB

**template**

Name of a member in the HSIACNTL file.

**TIME**

This operand is optional, and the default is TIME(0000-2400), which specifies no time-of-day constraint.

**hhmm-hhmm**

Specifies a time-of-day range. Each *hhmm* value is four contiguous decimal digits that specify a time-of-day using the 24-hour clock. The minimum value is 0000 and the maximum value is 2400; the last two digits must not exceed 59. The two values are separated by a hyphen. Zero or more additional blanks are also permitted. The first *hhmm* specifies the time-of-day window start, while the second specifies the time-of-day window end. The window includes times which are after the window start and before the window end. However, if the second *hhmm* value is lower than the first, the window includes times which are after the window start or before the window end.

**WEEK**

This operand is optional. The default is WEEK(YYYYYYY), which specifies that the *action* can be run on every day of the week.

**wkflags**

Specifies a single contiguous 7-byte string, consisting of the uppercase characters Y or N. Each Y or N corresponds to a day of the week depending on its position in the string; the first corresponding to Sunday, the last to Saturday. If the character corresponding to a day of the week is N, the action is not processed on that day.

**NOTB**

This operand is optional. The default NOTB(1) specifies that the monthly window starts on the first possible day of the month. NOTB means "not before".

**d1**

Specifies a one or two digit decimal number in the 1-31 range. This number denotes the first possible day of the month on which the action is permitted.

**NOTA**

This operand is optional. The default NOTA(31) specifies that the monthly window extends to the last day of the month. NOTA means "not after".

**d2**

Specifies a one or two digit decimal number in the 1-31 range. This number denotes the last possible day of the month on which the action is permitted.

**MNTH**

This operand is optional. The default value enables processing in every month of the year.

***mthflags***

Specifies a single contiguous 12-byte string, consisting of the uppercase characters Y or N. Each Y or N corresponds to a month of the year depending on its position in the string; the first corresponding to January, the last to December. If the character corresponding to a month of the year is N, the action is not processed in that month.

Figure 6. DSN statement syntax

►► **DSN**(*data-set-name-mask* — ) ►►

**DSN**

Data set name.

***data-set-name-mask***

Specifies a data set name mask pattern which does not exceed 44 characters in length, and is used by the Catalog Search Interface. The generic match mask for a single character is the percent sign. The generic match mask variable number of characters is the asterisk. A double asterisk can be used to match a variable number of data set name qualifiers. The catalog search is restricted to entry type A non-VSAM data sets and entry type H generation data sets.

**Control statement examples****Example 1:**

Files created by the Usage Monitor undergo two independent processes, both within the 8:00 p.m. to 11:30 p.m. window. They are processed by a job based on the JCL contained in member HSIJOB1, and are separately transferred to a z/OS® system using the FTP commands in member HSIFTP1. All members are pointed to by the HSIACNTL ddname.

```
* TRANSFER USAGE MONITOR FILES TO Z/OS SYSTEM
JOB(HSISJOB1) TIME(2000-2330)
DSN(USER.OMU*.D*.T*)
FTP(HSISFTP1) TIME(2000-2330)
DSN(USER.OMU*.D*.T*)
```

**Example 2:**

Files created by the Usage Monitor are to be imported to the appropriate database.

```
* PERFORM USAGE MONITOR IMPORT
JOB(HSISUIMP)
DSN(USER.UMON.*.*)
```

In this example HSIUIMP contains the necessary JCL to run Usage Import on a z/OS® system.



**Note:** The JCL can route the job to any connected NJE node, or specify an affinity to any system sharing the SPOOL. You do not need to run the job on the z/OS® system where the Automation Server



is running. The template name, HSIUIMP in this example, does not need to match the job name submitted by the Automation Server action.

**Example 3:**

A job stream stored in member WED2MNTH is to be submitted unconditionally on the second Wednesday of every month.

```
* RUN MONTHLY JOBSTREAM ON THE SECOND WEDNESDAY OF EVERY MONTH
JOB ( WED2MNTH ) WEEK ( NNNYN ) NOTB ( 8 ) NOTA ( 14 )
DSN ( NULLFILE )
```

**Example 4:**

A job stream stored in member NEWSHIFT is to run every day at 6:00 a.m, 2:00 p.m., and 10:00 p.m.

```
* RUN SHIFT TASK LIST REPORT AT THE START OF EACH SHIFT
JOB(NEWSHIFT) TIME(0600-0630)
DSN(NULLFILE)
JOB(NEWSHIFT) TIME(1400-1430)
DSN(NULLFILE)
JOB(NEWSHIFT) TIME(2200-2230)
DSN(NULLFILE)
```

**Automation Server symbol processing**

Whenever an action is performed, the contents of the template member are written to an appropriate output file. Each 80-byte record is written unchanged, unless symbol substitution is required. If an ampersand character is present in a record from the template member, the system symbol substitution routine ASASYMBM is called to process the record before it is written. You can use more than one symbol in a record. If an ampersand character does not denote the start of a recognized symbol, then that part of the data remains unchanged. Symbols available for use in template members include all z/OS® system symbols and symbols defined locally by the Automation Server. Most Automation Server local symbols are derived from the catalog entry data set name which, when discovered, triggers the instance of the action.

System symbols supplied by the operating system, as well as the &SMF and &SYSLPAR symbols supplied by the Automation Server, are available for use in the HSIAPARM member. The &SYSLPAR symbol might resolve to a null string if the system is running in a virtual machine.

Automation Server local symbols are provided in the following table:

**Table 18. Automation Server local symbols**

Symbol	Description
&SMF	System SMF identifier.
&SYSLPAR	System LPAR name.
&DATASETNAME.	The entire data set name.

Table 18. Automation Server local symbols

(continued)

Symbol	Description
&QUAL1.	The first qualifier of the data set name.
&QUAL2.	The second qualifier of the data set name.
&QUAL3.	The third qualifier of the data set name.
&QUAL4.	The fourth qualifier of the data set name.
&QUAL5.	The fifth qualifier of the data set name.
&QUAL6.	The sixth qualifier of the data set name.
&QUAL7.	The seventh qualifier of the data set name.
&QUAL8.	The eighth qualifier of the data set name.
&QUAL9.	The ninth qualifier of the data set name.

**Example:**

The data set triggering a JOB action is EXPUSER.IQ.ZIP. As a result, JCL DD statements referencing the data set in a template member can be represented as shown in this example:

```

/*-----***
/* Sample JCL demonstrating the use of Automation Server local***
/* symbols derived from the data set name.          ***
/*-----***
//BR14 EXEC PGM=IEFBR14
//DD1 DD DSN=&DATASETNAME.,DISP=SHR
//DD2 DD DSN=&QUAL1.&QUAL2.&QUAL3.,DISP=SHR

```

Both JCL DD statements would be resolved by symbol substitution to:

```
DSN=EXPUSER.IQ.ZIP,DISP=SHR
```

This is the **DSN=** JCL statement output to the internal reader.

As symbol substitution is performed before the job is submitted, z/OS® system symbols that cannot be used in batch job JCL, can be used in the Automation Server templates. The symbols are resolved using the system executing the Automation Server, which may not be the system where the submitted job executes.

## Starting and stopping the Automation Server

When you install the Automation Server as a started task, you can run operator commands to start it and stop it. This task requires RACF® security access.

## Procedure

1. Assign RACF® CONTROL access to the VSAM data set that is configured for the user ID that is assigned to the Automation Server.
2. Issue the system **START** command to start the Automation Server.
3. Issue the system **STOP** command to stop the Automation Server running as a started task or from running a batch job.

## Excluding data sets

You can exclude data sets from Automation Server processing. To exclude a data set, it must have a record in the Automation Server control data set, with an indication in the record that the data set is already processed.

In the HSIAPARM member you define actions to be performed, and supply data set name masks specifying the data sets to be processed by the Automation Server. Data sets with these name patterns might already exist and have been processed before the Automation Server was implemented.

To exclude a data set, the name of the data must satisfy a selection mask pattern. To implement the exclusion, you can use the Automation Server data set name scouting program. The HSISCUST post-installation job creates the HSIASSCT member in the JCLLIB data set. Run the HSIASSCT job to start the scouting program.

The program reads the HSIAPARM member, searches the catalog for every specified data set name mask, and writes a record for each data set that it discovers. The job then sorts the records into key order and copies them into the VSAM control data set. Every record loaded into the control data set in this way indicates a specific action with a status of complete.

If you want to continue processing some of the data sets, you can manually delete them from the sequential data set before the data is copied into the control data set.

## Automation Server control data set maintenance

A record is kept for every data set processed by the Automation Server in the Automation Server control data set, ACDS. The purpose of this record is to prevent the repeated processing of a data set for the same data set name mask. As records accrue, the size of the data in the ACDS continues to grow.

If a processed data set is deleted, or a data set name mask is removed from the set of masks processed by the Automation Server, then there is no reason to keep a record of that data set in the ACDS. The Automation Server performs a cleanup cycle for the ACDS on a daily basis. This cleanup cycle consists of reading the ACDS sequentially, and deleting records for data sets which have not been found by catalog search. This is based on the relevant data set name mask in the current calendar month, or in the prior calendar month.

As with most VSAM data sets with ongoing record insertion and deletion activity, it is advisable to periodically reorganize the ACDS.

# Chapter 7. Reporting with the Analyzer

The primary reporting facility in IBM Z Software Asset Management is the Analyzer.

The Analyzer runs as a started task or batch job on the same z/OS® host as the Db2® Subsystem or SQLite database that contains the IBM Z Software Asset Management database(s).

The Analyzer has two modes:

## **Online mode**

A PC Browser, for example Firefox, is used to communicate with the Analyzer for interactive queries.

## **Batch mode**

This mode uses the Analyzer to generate the report to an output file. The Batch mode is useful when you want to automate reports or develop your own reports. Batch mode is also useful when you want to select multiple criteria, such as multiple libraries or multiple users which you cannot do online from some reports.

All Analyzer reports can be run in online and batch modes and can produce the following output formats:

- XML (xml)
- HTML (htm)
- Excel (Excel)
- Text line (txt)
- Comma Separated Value (csv)

## Analyzer prerequisites

The Analyzer uses the Db2® Call Library Interface (ODBC/CLI), also used by the Inquisitor Import, Usage Import and other batch components, and the z/OS® socket application programming interface. For the SQLite database, the Analyzer uses an internal ODBC interface.

There is no dependency on any other middleware components. For example, no dependency exists on the HTTP Server, WebSphere® Application Server, or Java™.

The Analyzer has been designed with minimal prerequisites. These are:

- The Analyzer must be run on the same z/OS® host as the Db2® subsystem or SQLite database that contains the IBM Z Software Asset Management repositories.
- The user ID of the Analyzer address space must have previously been granted access to the databases. See the HSISGRNT job in the JCLLIB for sample JCL to grant access.
- When running the Analyzer in the online mode, you need access to a TCP/IP port. The default is port 9000.
- When running the Analyzer in online mode with SECURITY=SYSTEM, the Analyzer SHSIMOD1 load library must be defined to the z/OS® Authorized Program Facility (APF). In addition, all data sets in the Analyzer STEPLIB, or JOBLIB DD concatenation, must be defined to APF.

- You can run the Analyzer in online mode while Inquisitor Import or Usage Import is also updating data into the repositories. However, the Analyzer reports may not display the correct information on the latest updates due to concurrency issues in Db2®. To ensure that the latest correct information is displayed, do not run operational jobs that update data in the repositories while users are running reports with the Analyzer. This is not an issue for the SQLite database, as only single thread is allowed.

## Analyzer JCLLIB and PARMLIB members

Several JCLLIB and PARMLIB members are used when you run the Analyzer to generate reports.

The members in the JCLLIB contain sample JCL to run the Analyzer.

**Table 19. JCLLIB members for Analyzer**

Member	Description
HSIJANLO	Analyzer PROC for online mode. Copy this PROC from the JCLLIB to a system PROCLIB data set to run the Analyzer as a started task
HSISANLB	Analyzer batch job for batch mode
HSISANLO	Analyzer batch job for online mode
HSISANS1	Define the Analyzer security profiles in RACF® (only applicable for Analyzer SECURITY=SYSTEM setting)
HSISANS2	Generate the Analyzer SSL certificate in RACF® (only applicable for Analyzer SECURITY=SYSTEM setting)
HSISANS3	Connect the Analyzer user ID to an existing SSL certificate in RACF® (only applicable for Analyzer SECURITY=SYSTEM setting)

The following members in the PARMLIB contain sample configuration settings for the Analyzer in online mode. These members are referenced with the TPARAM setting in the HSIJANLO PROC.

**Table 20. PARMLIB members for Analyzer**

Member	Description
HSISANP1	SECURITY=BASIC  HTTP communications with basic security
HSISANP2	SECURITY=SYSTEM  HTTPS (SSL encrypted) communications with z/OS system security (SAF/RACF)  Refer to the HSISANS1, HSISANS2, and HSISANS3 members in JCLLIB for sample JCL to define RACF profiles/certificates.

## Running the Analyzer in online mode

The primary reporting facility in IBM Z Software Asset Management is the Analyzer. You can use the Analyzer in online mode to view reports, run queries, and drill down to related reports.

### About this task



**Note:** The V8.3 Analyzer will support only V8.3 repositories. Repositories from V8.2 are NOT supported and will not appear in the V8.3 Analyzer.



**Note:** Db2 only: It is recommended that not more than 50 repositories be defined in a Db2 subsystem that is referenced by each Analyzer. This is to prevent overload to the Analyzer and also for easier management of repositories.

Db2 only:

1. The Db2 subsystem must first be active before starting up the Analyzer. After the Analyzer starts, it needs to access the Db2 Catalogs to obtain the list of repositories. If the Db2 subsystem is not active, the error message below appears in the Analyzer joblog.

```
13:15:09(0) COULD NOT QUERY SYSIBM.SYSTABLES FOR REPOSITORY -
SQLAllocHandle for connection handle failed - rc -1
{DB2 FOR OS/390}{ODBC DRIVER} SQLSTATE=58004 ERRLOC=2:56:9
CAF "CONNECT" failed using DB2 system:DSN1
RC=08 and REASON=00f30012
```

2. The Db2 subsystem can be stopped while the Analyzer is still active, but it will remain in a wait state. If a user logs in and tries to access a repository, the error message below will appear on the Analyzer report. When the Db2 subsystem is next started, users can login again and will automatically re-establish connection to Db2.

```
SQLAllocHandle for connection handle failed
- rc -1
{DB2 FOR OS/390}{ODBC DRIVER} SQLSTATE=58004 ERRLOC=2:56:9
CAF "CONNECT" failed using DB2 system:DSN1
RC=08 and REASON=00f30012
```

HSISANLO job in the JCLLIB is used to run Analyzer in online mode as a batch job.

```
//HSISANLO EXEC HSIJANLO,TPARAM=HSISANP1
```

To run the Analyzer in online mode as a Started Task, copy the HSIJANLO from the JCLLIB to a system PROCLIB data set. Here is a sample for running the started task in a Db2 subsystem.

```
//HSIJANLO PROC TPARAM='HSISANP1',    TPARAM input parms
//      CUST='HSISANCQ',
//      CLI='HSISCLI'
//*
//ANALYZER EXEC PGM=HSICANLZ,REGION=0M,TIME=NOLIMIT
//STEPLIB DD DISP=SHR,DSN=&DB2EXIT
//      DD DISP=SHR,DSN=&DB2LOAD
```

```

// DD DISP=SHR,DSN=&HSI..SHSIMOD1
// DD DISP=SHR,DSN=&CEERUN
// DD DISP=SHR,DSN=&CBCDLL
//SYSPRINT DD SYSOUT=*,LRECL=500
//HSIANL1 DD DISP=SHR,DSN=&HSI..SHSIANL1
//HSIANL2 DD DISP=SHR,DSN=&HSI..SHSIANL2
//HSICUST DD DISP=SHR,
// DSN=&HSIINST..&DB..PARMLIB(&&CUST)
/*HSINLS DD DISP=SHR,DSN=&HSI..SHSIANL1(HSINLSJP)
//TPARAM DD DISP=SHR,
// DSN=&HSIINST..&DB..PARMLIB(&&TPARAM)
//DSNAOINI DD DISP=SHR,
// DSN=&HSIINST..&DB..PARMLIB(&&CLI)
//WORK0 DD DISP=(NEW,DELETE),
// UNIT=SYSALLDA,SPACE=(CYL,(100,50),RLSE)
//APPSTATS DD SYSOUT=*,LRECL=1000
//APPTRACE DD SYSOUT=*

```

```

//HZAANLO PROC TPARAM='HZASANP1', TPARAM input parms
// CUST='HZASANCQ',
// CLI='HZASCLI'
/*Running in Environment DBTYPE=DB2
/******
/* Procedure to run the Analyzer. ***
/* ***
/* Note that the Analyzer will support only ZAO V1.1 repositories. ***
/* ***
/* Useful Analyzer commands: ***
/* S HZAANLO - Start the Analyzer ***
/* P HZAANLO - Stop the Analyzer ***
/* F HZAANLO,STOP - Stop the Analyzer ***
/* F HZAANLO,REFRESH - Refresh Analyzer report templates and NLS ***
/* F HZAANLO,TRACE - Toggle tracing on and off ***
/* ***
/******
//ANALYZER EXEC PGM=HZACANLZ,REGION=0M,TIME=NOLIMIT
//STEPLIB DD DISP=SHR,DSN=DB2VC10.DEC3.SDSNEXIT
// DD DISP=SHR,DSN=DB2.VC10.SDSNLOAD
// DD DISP=SHR,DSN=HZADEV.V110.SHZAMOD1
// DD DISP=SHR,DSN=CEE.SCEERUN
// DD DISP=SHR,DSN=CBC.SCLBDLL
//SYSPRINT DD SYSOUT=*,LRECL=500
//HZAANL1 DD DISP=SHR,DSN=HZADEV.V110.SHZAANL1
//HZAANL2 DD DISP=SHR,DSN=HZADEV.V110.SHZAANL2
//HZACUST DD DISP=SHR,
// DSN=ZAOATEST.DEC3.ZAOV12.TFZAORC3.PARMLIB(&CUST)
/*HZANLS DD DISP=SHR,DSN=HZADEV.V110.SHZAANL1(HZANLSJP)
//TPARAM DD DISP=SHR,
// DSN=ZAOATEST.DEC3.ZAOV12.TFZAORC3.PARMLIB(&TPARAM)
//DSNAOINI DD DISP=SHR,
// DSN=ZAOATEST.DEC3.ZAOV12.TFZAORC3.PARMLIB(&CLI)
//WORK0 DD DISP=(NEW,DELETE),
// UNIT=SYSALLDA,SPACE=(CYL,(100,50),RLSE)
//APPSTATS DD SYSOUT=*,LRECL=1000
//APPTRACE DD SYSOUT=*

```

When the Analyzer is run with online mode, configuration options must be defined in the TPARAM DD, including the communication port, security mode, and inactivity timeout.

## Analyzer communication port

The Analyzer communication port is defined by using the HTTPPORT setting.

Both sample PARMLIB members HSISANP1 (basic security) and HSISANP2 (system security), have the following:

```
*****
* HTTPPORT defines the TCP/IP port used for communications.      *
*                                                                 *
* If HTTPPORT = 9000 is defined on a system with a TCP/IP host   *
* called sys1.mycompany.com, to access the Analyzer the user     *
* would specify the following URL in their PC Browser:           *
*   http://sys1.mycompany.com:9000 if SECURITY=BASIC              *
* or https://sys1.mycompany.com:9000 if SECURITY=SYSTEM          *
*                                                                 *
* The port specified must be available on your system.           *
*                                                                 *
* TSO NETSTAT can be used to check if a port is available e.g.:  *
* TSO NETSTAT (PORT 9000 --* is port 9000 in use?               *
* TSO NETSTAT PORTL(PORT 9000 --* is port 9000 reserved?        *
*                                                                 *
* If no entries are returned from these NETSTAT commands, the port *
* is most probably available. At some sites, you may need your   *
* Network Systems Programmer to reserve a port for IZSAM Analyzer. *
*                                                                 *
*****
HTTPPORT = 9000
```

```
*****
* HTTPPORT defines the TCP/IP port used for communications.      *
*                                                                 *
* If HTTPPORT = 9000 is defined on a system with a TCP/IP host   *
* called sys1.mycompany.com, to access the ZAO Analyzer the user  *
* would specify the following URL in their PC Browser:           *
*   http://sys1.mycompany.com:9000 if SECURITY=BASIC              *
* or https://sys1.mycompany.com:9000 if SECURITY=SYSTEM          *
*                                                                 *
* The port specified must be available on your system.           *
*                                                                 *
* TSO NETSTAT can be used to check if a port is available e.g.:  *
* TSO NETSTAT (PORT 9000 --* is port 9000 in use?               *
* TSO NETSTAT PORTL(PORT 9000 --* is port 9000 reserved?        *
*                                                                 *
* If no entries are returned from these NETSTAT commands, the port *
* is most probably available. At some sites, you may need your   *
* Network Systems Programmer to reserve a port for ZAO Analyzer.  *
*                                                                 *
*****
HTTPPORT = 9000
```

If HTTPPORT is not specified, or is set to 0, the Analyzer fails with message "COULD NOT OPEN DD:SYSIN".

## Analyzer inactivity timeout

The Analyzer communication inactivity timeout is defined by using the INACTIVITY\_TIMEOUT setting.

Both sample PARMLIB members HSISANP1 (basic security) and HSISANP2 (system security), have the following:

```
*****
* INACTIVITY_TIMEOUT defines the inactivity timeout in minutes. *
* *
* The minimum value is 5 and the maximum is 9999. *
* *
* If INACTIVITY_TIMEOUT = 0 is defined, no timeout will occur. *
*****
```

If INACTIVITY\_TIMEOUT is not specified, then it defaults to 30 minutes.

## Analyzer security

You can view Analyzer reports in a web browser, such as Firefox, and you can communicate with the Analyzer utility to perform interactive queries.

Some of the Analyzer reports contain a large amount of information and it is recommended that you use a screen resolution of at least 1440 x 900 pixels to view them.

The following table describes the security modes that you can configure for accessing Analyzer online.

**Table 21. Security modes for accessing Analyzer online**

Security configuration	Communication mode	Access ID and password	Access permissions
SECURITY=BASIC	HTTP	Standard user ID and password. Default values are: <ul style="list-style-type: none"> <li>• User: <code>izsamusr</code> and password <code>IZSAM</code></li> <li>• Admin: <code>izsamadm</code> and password <code>IZSAM</code></li> </ul>	User ID <code>izsamusr</code> has limited access. User ID <code>izsamadm</code> has full access.
SECURITY=SYSTEM	HTTPS	z/OS® system user ID and password Default: User TSO ID and password	Depends on the users' access to the HSICANLZ application and various Z SW Asset Mgmt and Db2® resources

## Analyzer BASIC security

HSISANP1 in the PARMLIB defines basic user ID security settings for running the Analyzer.

User IDs IZSAMADM and IZSAMUSR can be used without any prior configuration. User ID AUID001 is a sample of how to restrict a user ID to certain databases.

```

*****
* SECURITY=BASIC - HTTP communications *
* with basic security defined in TPARAM DD below. *
* *
*****
SECURITY = BASIC

*****
* The following settings are only applicable for *
* SECURITY=BASIC: *
* *
* AUTH_USER defines Userids and passwords for Analyzer logon *
* AUTH_DB defines the repositories access *
* AUTH_MENU defines the menus access *
* *
* The sample settings profile: *
* - IZSAMADM userid: *
* - Password IZSAM *
* - Access to all repositories *
* - Access to all menu tabs *
* - IZSAMUSR userid: *
* - Password IZSAM *
* - Access to all repositories *
* - Access to menu tabs ASSET, DISC + CUSTOM + ADMINR only *
* - AUID001 userid: *
* - Password PW01 *
* - Access to repositories AUID001 + AUID002 only *
* - Access to menu tab ASSET only *
*****

*-----*
*AUTH_USER= USERID , PASSWORD *
*-----*
AUTH_USER = IZSAMADM , IZSAM
AUTH_USER = IZSAMUSR , IZSAM
AUTH_USER = AUID001 , PW01

*-----*
*AUTH_DB = REPOSITORY, LIST OF USERIDS AUTHORIZED TO SEE THE *
* REPOSITORIES *
*-----*
AUTH_DB = * , IZSAMADM IZSAMUSR
AUTH_DB = AUID001 , AUID002
AUTH_DB = AUID001 , AUID002

*-----*
*AUTH_MENU= MENU_TAB , LIST OF USERIDS AUTHORIZED TO SEE THE MENU TAB *
*-----*
AUTH_MENU = ASSET , IZSAMADM IZSAMUSR AUID001
AUTH_MENU = DISC , IZSAMADM IZSAMUSR
AUTH_MENU = ADMINR , IZSAMADM, IZSAMUSR
AUTH_MENU = ADMIN , IZSAMADM
AUTH_MENU = CUSTOM , IZSAMADM IZSAMUSR
* Activation/deactivation of the new Lib Classification items.
* ADMIN displays Admin menu with lib classification items deactivated.
* (Must specify this to see the Admin menu at all)
* ADMIN(LIB_CLASSIFICATION) activates the lib classification items for the specified users.
* AUTH_MENU = ADMIN(LIB_CLASSIFICATION) , IZSAMADM

```

```

*****
* SECURITY=BASIC - HTTP communications *
* with basic security defined in TPARAM DD *
* *
*****
SECURITY = BASIC

*****
* The following settings are only applicable for *
* SECURITY=BASIC: *
* *
* AUTH_USER defines Userids and passwords for Analyzer logon *
* AUTH_DB defines the databases access *
* AUTH_MENU defines the menus access *
* *
* The sample settings profile: *
* - ZAOADM userid: *
* - Password ZAO *
* - Access to all databases *
* - Access to all menu tabs *
* - ZAOUR user: *
* - Password ZAO *
* - Access to all databases *
* - Access to menu tabs ASSET, DISC + CUSTOM only (not ADMIN) *
* - AUID001 userid: *
* - Password PW01 *
* - Access to databases AUID001 + AUID002 only *
* - Access to menu tab ASSET only *
*****

*-----*
*AUTH_USER= USERID , PASSWORD *
*-----*

AUTH_USER = ZAOADM , ZAO
AUTH_USER = ZAOUR , ZAO
AUTH_USER = AUID001 , PW01

*-----*
*AUTH_DB = DATABASE , LIST OF USERIDS AUTHORIZED TO SEE THE DATABASE *
*-----*

AUTH_DB = * , ZAOADM ZAOUR
AUTH_DB = AUID001 , AUID001
AUTH_DB = AUID002 , AUID001

*-----*
*AUTH_MENU= MENU_TAB , LIST OF USERIDS AUTHORIZED TO SEE THE MENU TAB *
*-----*

AUTH_MENU = ASSET , ZAOADM ZAOUR AUID001
AUTH_MENU = DISC , ZAOADM ZAOUR
AUTH_MENU = ADMIN , ZAOADM
AUTH_MENU = CUSTOM , ZAOADM ZAOUR

```

## Analyzer SYSTEM security

HSISANP2 in the PARMLIB defines the system security settings for running the Analyzer.

The following system security settings are defined:

```

*****
* IZSAM Analyzer on-line mode settings for z/OS SYSTEM security *
*
*****
* SECURITY=SYSTEM - HTTPS (SSL encrypted) communications *
* with z/OS system security (SAF/RACF). *
* Refer to HSISANS1/2/3 in JCLLIB for sample JCL *
* to define RACF profiles/certificates. *
*
*****
SECURITY = SYSTEM

*****
* The following settings are only applicable for *
* SECURITY=SYSTEM: *
*
* AUTH_HLQ defines SAF/RACF profile high level qualifier *
*
* AUTH_UPPERCASE=Y Analyzer will uppercase passwords when *
* invoking SAF/RACF password authentication. *
* When password phrase support has been *
* enabled AUTH_UPPERCASE=Y has no effect, and *
* mixed case is used. *
* AUTH_UPPERCASE=N Analyzer will pass through mixed case passwords *
* when invoking SAF/RACF password authentication *
*
* GSK_KEYRING_FILE defines SAF/RACF Keyring name of SSL Certificate *
* GSK_KEY_LABEL defines SAF/RACF Label name of SSL Certificate *
* GSK_.... defines optional z/OS SSL environment variables. *
* The z/OS Cryptographic Services Secure Sockets *
* Layer Programming manual explains the *
* environment variables. *
* For example, define GSK_HW_CRYPT0 = 32 *
* for SHA-256 digest generation. *
*
* JCLLIB(HSISANS1) contains sample JCL to define RACF profiles, using *
* a high level qualifier of 'IZSAM'. If you have changed HSISANS1, *
* you may also need to change the AUTH_HLQ TPARAM setting. *
*
* JCLLIB(HSISANS2/3) contains sample JCL to define RACF SSL *
* Certificates. If you have changes HSISANS2/3, you may also need to *
* change the GSK_KEYRING_FILE and GSK_KEY_LABEL TPARAM settings. *
*
*****
AUTH_HLQ = IZSAM
AUTH_UPPERCASE = Y
GSK_KEYRING_FILE = ZSAM_KEYRING
GSK_KEY_LABEL = ZSAMCERT

```

```

*****

```

```

* SECURITY=SYSTEM - HTTPS (SSL encrypted) communications *
*   with z/OS system security (SAF/RACF). *
*   Refer to HZASANS1/2/3 in JCLLIB for sample JCL *
*   to define RACF profiles/certificates. *
*
*****
SECURITY = SYSTEM
*****

* The following settings are only applicable for *
* SECURITY=SYSTEM: *
*
* AUTH_HLQ    defines SAF/RACF profile high level qualifier *
*
* AUTH_UPPERCASE=Y Analyzer will uppercase passwords when *
*   invoking SAF/RACF password authentication *
* AUTH_UPPERCASE=N Analyzer will pass through mixed case passwords *
*   when invoking SAF/RACF password authentication *
*
* GSK_KEYRING_FILE defines SAF/RACF Keyring name of SSL Certificate *
* GSK_KEY_LABEL    defines SAF/RACF Label name of SSL Certificate *
* GSK_....        defines optional z/OS SSL environment variables. *
*   The z/OS Cryptographic Services Secure Sockets *
*   Layer Programming manual explains the *
*   environment variables. *
*   For example, define GSK_HW_CRYPTO = 32 *
*   for SHA-256 digest generation. *
*
* JCLLIB(HZASANS1) contains sample JCL to define RACF profiles, using *
* a high level qualifier of 'ZAO'. If you have changed HZASANS1, *
* you may also need to change the AUTH_HLQ TPARAM setting. *
*
* JCLLIB(HZASANS2/3) contains sample JCL to define RACF SSL *
* Certificates. If you have changes HZASANS2/3, you may also need to *
* change the GSK_KEYRING_FILE and GSK_KEY_LABEL TPARAM settings. *
*
*****
AUTH_HLQ    = ZAO
AUTH_UPPERCASE = Y
GSK_KEYRING_FILE = ZAO_KEYRING
GSK_KEY_LABEL  = ZAOCERT

```

HSISANS1 in the JCLLIB has sample JCL to define RACF® security profiles.



**Note:** The RACF® ID can be an existing RACF® group (which user IDs have been connected to) and/or existing RACF® user IDs.

If your z/OS® system has been set up to use a third party alternative to RACF®, you must define comparable settings in your third party security product.

```

/*-----*/
/* IZSAM ANALYZER DATABASE PROFILES */
/*-----*/
RDELETE FACILITY IZSAM.DB.AU*
RDEFINE FACILITY IZSAM.DB.AU* UACC(NONE)

```

```

PERMIT      IZSAM.DB.AU*    ACCESS(READ) -
CLASS(FACILITY) ID(IZSAMADM,IZSAMUSR,AUID001)

RDELETE FACILITY IZSAM.DB.*
RDEFINE FACILITY IZSAM.DB.*      UACC(NONE)
PERMIT      IZSAM.DB.*    ACCESS(READ) -
CLASS(FACILITY) ID(IZSAMADM,IZSAMUSR)
PERMIT      IZSAM.DB.*    ACCESS(NONE) -
CLASS(FACILITY) ID(AUID001)
/*-----*/
/* IZSAM ANALYZER MENU PROFILES          */
/*-----*/
RDELETE FACILITY IZSAM.MENU.ASSET
RDEFINE FACILITY IZSAM.MENU.ASSET  UACC(NONE)
PERMIT      IZSAM.MENU.ASSET  ACCESS(READ) -
CLASS(FACILITY) ID(IZSAMADM,IZSAMUSR,AUID001)

RDELETE FACILITY IZSAM.MENU.DISC
RDEFINE FACILITY IZSAM.MENU.DISC  UACC(NONE)
PERMIT      IZSAM.MENU.DISC  ACCESS(READ) -
CLASS(FACILITY) ID(IZSAMADM,IZSAMUSR)

RDELETE FACILITY IZSAM.MENU.ADMINR
RDEFINE FACILITY IZSAM.MENU.ADMINR UACC(NONE)
PERMIT      IZSAM.MENU.ADMINR  ACCESS(READ) -
CLASS(FACILITY) ID(IZSAMADM,IZSAMUSR)

RDELETE FACILITY IZSAM.MENU.ADMIN
RDEFINE FACILITY IZSAM.MENU.ADMIN  UACC(NONE)
PERMIT      IZSAM.MENU.ADMIN  ACCESS(READ) -
CLASS(FACILITY) ID(IZSAMADM)

RDELETE FACILITY IZSAM.MENU.ADMIN.LIB_CLASSIFICATION
RDEFINE FACILITY IZSAM.MENU.ADMIN.LIB_CLASSIFICATION UACC(NONE)
PERMIT      IZSAM.MENU.ADMIN.LIB_CLASSIFICATION ACCESS(READ) -
CLASS(FACILITY) ID(IZSAMADM)

RDELETE FACILITY IZSAM.MENU.CUSTOM
RDEFINE FACILITY IZSAM.MENU.CUSTOM  UACC(NONE)
PERMIT      IZSAM.MENU.CUSTOM  ACCESS(READ) -
CLASS(FACILITY) ID(IZSAMADM,IZSAMUSR)

SETROPTS RACLIST(FACILITY) REFRESH

```

```

/*-----*/
/* ZAO ANALYZER DATABASE PROFILES      */
/*-----*/
RDELETE FACILITY ZAO.DB.AU*
RDEFINE FACILITY ZAO.DB.AU*      UACC(NONE)
PERMIT      ZAO.DB.AU*    ACCESS(READ) -
CLASS(FACILITY) ID(ZAOADM,ZAOUSR,AUID001)

RDELETE FACILITY ZAO.DB.*
RDEFINE FACILITY ZAO.DB.*      UACC(NONE)
PERMIT      ZAO.DB.*    ACCESS(READ) -
CLASS(FACILITY) ID(ZAOADM,ZAOUSR)
PERMIT      ZAO.DB.*    ACCESS(NONE) -

```

```

CLASS(FACILITY) ID(AUID001)

/*-----*/
/* ZAO ANALYZER MENU PROFILES          */
/*-----*/
RDELETE FACILITY ZAO.MENU.ASSET
RDEFINE FACILITY ZAO.MENU.ASSET  UACC(NONE)
PERMIT    ZAO.MENU.ASSET  ACCESS(READ) -
CLASS(FACILITY) ID(ZAOADM,ZAOUSR,AUID001)

RDELETE FACILITY ZAO.MENU.DISC
RDEFINE FACILITY ZAO.MENU.DISC  UACC(NONE)
PERMIT    ZAO.MENU.DISC  ACCESS(READ) -
CLASS(FACILITY) ID(ZAOADM,ZAOUSR)

RDELETE FACILITY ZAO.MENU.ADMIN
RDEFINE FACILITY ZAO.MENU.ADMIN  UACC(NONE)
PERMIT    ZAO.MENU.ADMIN  ACCESS(READ) -
CLASS(FACILITY) ID(ZAOADM)

RDELETE FACILITY ZAO.MENU.CUSTOM
RDEFINE FACILITY ZAO.MENU.CUSTOM  UACC(NONE)
PERMIT    ZAO.MENU.CUSTOM  ACCESS(READ) -
CLASS(FACILITY) ID(ZAOADM,ZAOUSR)

SETROPTS RACLIST(FACILITY) REFRESH

```

## SSL Certificates

When the Analyzer is running with SYSTEM=SECURITY, you must have an SSL Certificate defined in your SAF/RACF® security system. You can either generate your own certificate, or connect to an existing certificate.

HSISANS2 in JCLLIB has sample JCL to generate SSL certificates in RACF®.

```

/*-----*
/*
/* To enable IZSAM Analyzer to use HTTP secure (HTTPS) the following *
/* steps should be implemented by your site's RACF Administrator:  *
/* 1. Delete KEYRING(IZSAM_KEYRING) and certificates with the     *
/* labels IZSAMCERT and LOCALCA.                                  *
/* 2. Activate RACF Classes required for digital certificates.    *
/* 3. Define Keyring IZSAM_KEYRING.                               *
/* 4. Generate certificate.                                       *
/* 5. Connect to Keyring.                                         *
/* 6. Refresh RACF Classes required for digital certificates.    *
/* 7. Permit access to the Facility Class profiles and refresh.  *
/*
/*
/* The following JCL demonstrates a sample implementation:      *
/* 1. Update all occurrences of "Userid-running-HSISANLO" to reflect *
/* your IZSAM HTTPS environment.                                  *
/*
/* Do not change the RACF keyring 'IZSAM_KEYRING' or label      *
/* 'IZSAMCERT' unless you update the corresponding values in Analyzer*
/* PARMLIB member HSISANP2 and restart the Analyzer STC/Job.    *
/*-----*

```

```

//RACFDEF EXEC PGM=IKJEFT01,DYNAMNBR=30
//SYSTSPRT DD SYSOUT=*
//SYSTSIN DD *
PROF NOPREF

RACDCERT DELETE(LABEL('LOCALCA')) CERTAUTH
RACDCERT DELETE(LABEL('IZSAMCERT')) ID(Userid-running-HSISANLO)
RACDCERT ID(Userid-running-HSISANLO) DELRING(IZSAM_KEYRING)

SETROPTS CLASSACT(DIGTCERT,DIGTNMAP)

RACDCERT ID(Userid-running-HSISANLO) ADDRING(IZSAM_KEYRING)

RACDCERT ID(Userid-running-HSISANLO) CERTAUTH GENCERT -
SUBJECTSDN( O('Your Organization') -
CN('Your Domain') -
C('US')) TRUST -
WITHLABEL('LOCALCA') -
KEYUSAGE(CERTSIGN)

RACDCERT ID(Userid-running-HSISANLO) GENCERT -
SUBJECTSDN (CN('IZSAMCERT') -
OU('Your Dept.') -
C('US')) -
WITHLABEL('IZSAMCERT') -
SIGNWITH(CERTAUTH -
LABEL('LOCALCA'))

RACDCERT ID(Userid-running-HSISANLO) -
CONNECT(ID(Userid-running-HSISANLO) -
LABEL('IZSAMCERT') -
RING(IZSAM_KEYRING) -
DEFAULT -
USAGE(PERSONAL))

RACDCERT ID(Userid-running-HSISANLO) -
CONNECT(ID(Userid-running-HSISANLO) CERTAUTH -
LABEL('LOCALCA') -
RING(IZSAM_KEYRING) -
USAGE(CERTAUTH))

SETROPTS RACLIST(DIGTCERT,DIGTNMAP) REFRESH
/*
//PERMIT EXEC PGM=IKJEFT01,DYNAMNBR=30
//SYSTSPRT DD SYSOUT=*
//SYSTSIN DD *
PROF NOPREF

RDEL FACILITY IRR.DIGTCERT.LIST
RDEL FACILITY IRR.DIGTCERT.LISTRING

RDEFINE FACILITY IRR.DIGTCERT.LIST UACC(NONE)
RDEFINE FACILITY IRR.DIGTCERT.LISTRING UACC(NONE)

PERMIT IRR.DIGTCERT.LIST CLASS(FACILITY) -
ID(Userid-running-HSISANLO) AC(READ)

```

```
PERMIT IRR.DIGTCERT.LISTRING CLASS(FACILITY) -
ID(Userid-running-HSISANLO) AC(READ)
```

```
SETR RACLIST(FACILITY) REFRESH
```

```
/*
```

```

/******
/*
/* To enable ZAO Analyzer to use HTTP secure (HTTPS) the following *
/* steps should be implemented by your site's RACF Administrator: *
/* 1. Delete KEYRING(ZAO_KEYRING) and certificate with the *
/* LABEL('ZAOCERT'). *
/* 2. Activate RACF Classes required for digital certificates. *
/* 3. Define Keyring ZAO_KEYRING. *
/* 4. Generate certificate. *
/* 5. Connect to Keyring. *
/* 6. Refresh RACF Classes required for digital certificates. *
/* 7. Permit access to the Facility Class profiles. *
/*
/*
/* The following JCL demonstrates a sample implementation: *
/* 1. Update all occurrences of "Userid-running-HZASANLO" to reflect *
/* your ZAO HTTPS environment. *
/*
/* Do not change the RACF keyring 'ZAO_KEYRING' or label 'ZAOCERT' *
/* unless you update the corresponding values in analyzer PARMLIB *
/* member HZASANP2 and restart the Analyzer STC/Job. *
/*-----*
//RACFDEF EXEC PGM=IKJEFT01,DYNAMNBR=30
//SYSTSPRT DD SYSOUT=*
//SYSTSIN DD *
PROF NOPREF

RACDCERT DELETE(LABEL('ZAOCERT'))
RACDCERT ID(CMACN) DELRING(ZAO_KEYRING)

SETROPTS CLASSACT(DIGTCERT,DIGTNMAP)
SETROPTS RACLIST(DIGTCERT,DIGTNMAP)

RACDCERT ID(Userid-running-HZASANLO) ADDRING(ZAO_KEYRING)

RACDCERT ID(Userid-running-HZASANLO) CERTAUTH GENCERT -
SUBJECTSDN( O('Your Organization') -
CN('Your Domain') -
C('US')) TRUST -
WITHLABEL('LOCALCA') -
KEYUSAGE(CERTSIGN)

RACDCERT ID(Userid-running-HZASANLO) GENCERT -
SUBJECTSDN (CN('ZAOCERT') -
OU('Your Dept.') -
C('US')) -
WITHLABEL('ZAOCERT') -
SIGNWITH(CERTAUTH -
LABEL('LOCALCA'))

```

```

RACDCERT ID(Userid-running-HZASANLO) -
CONNECT(ID(Userid-running-HZASANLO) -
LABEL('ZAOCERT') -
RING(ZAO_KEYRING) -
DEFAULT -
USAGE(PERSONAL))

RACDCERT ID(Userid-running-HZASANLO) -
CONNECT(ID(Userid-running-HZASANLO) CERTAUTH -
LABEL('LOCALCA') -
RING(ZAO_KEYRING) -
USAGE(CERTAUTH))

SETROPTS RACLIST(DIGTCERT,DIGTNMAP) REFRESH
/*
//PERMIT EXEC PGM=IKJEFT01,DYNAMNBR=30
//SYSTSPRT DD SYSOUT=*
//SYSTSIN DD *
PROF NOPREF

RDEL FACILITY IRR.DIGTCERT.LIST
RDEL FACILITY IRR.DIGTCERT.LISTRING
SETR RACLIST(FACILITY) REFRESH

RDEFINE FACILITY IRR.DIGTCERT.LIST UACC(NONE)
RDEFINE FACILITY IRR.DIGTCERT.LISTRING UACC(NONE)
SETR RACLIST(FACILITY) REFRESH

PERMIT IRR.DIGTCERT.LIST CLASS(FACILITY) -
ID(Userid-running-HZASANLO) AC(READ)

PERMIT IRR.DIGTCERT.LISTRING CLASS(FACILITY) -
ID(Userid-running-HZASANLO) AC(READ)

SETR RACLIST(FACILITY) REFRESH
/*

```

HSISANS3 in JCLLIB has sample JCL to connect to existing SSL certificates in RACF®.

```

/******
/*
/* To enable IZSAM Analyzer to use HTTP secure (HTTPS) using an
/* existing CA certificate, 'Entrust Secure Server Root CA' in our
/* example, the following steps should be implemented by your site's
/* RACF Administrator:
/*
/* 1. Delete KEYRING(IZSAM_KEYRING) and certificate with the
/* LABEL('IZSAMCERT').
/* 2. Activate RACF Classes required for digital certificates.
/* 3. Define Keyring IZSAM_KEYRING.
/* 4. Connect the existing CA certificate to the Keyring.
/* 5. Refresh RACF Classes required for digital certificates.
/* 6. Permit access to the Facility Class profiles.
/*
/*
/*

```

```

/* The following JCL demonstrates a sample implementation:          *
/* 1. Update all occurrences of "Userid-running-HSISANLO" to reflect *
/* your IZSAM HTTPS environment.                                  *
/*                                                                *
/* Do not change the RACF keyring 'IZSAM_KEYRING' or label 'IZSAMCERT'
/* unless you update the corresponding values in Analyzer PARMLIB *
/* member HSISANP2 and restart the Analyzer STC/Job.             *
/*-----*
//RACFDEF EXEC PGM=IKJEFT01,DYNAMNBR=30
//SYSTSPRT DD SYSOUT=*
//SYSTSIN DD *
PROF NOPREF

RACDCERT DELETE(LABEL('IZSAMCERT')) ID(Userid-running-HSISANLO)
RACDCERT ID(Userid-running-HSISANLO) DELRING(IZSAM_KEYRING)

SETROPTS CLASSACT(DIGTCERT,DIGTNMAP)

RACDCERT ID(Userid-running-HSISANLO) ADDRING(IZSAM_KEYRING)

RACDCERT ID(Userid-running-HSISANLO) GENCERT -
SUBJECTSDN (CN('IZSAMCERT')) -
OU('Your Dept.') -
C('US')) -
WITHLABEL('IZSAMCERT')

RACDCERT ID(Userid-running-HSISANLO) -
CONNECT(ID(Userid-running-HSISANLO) -
LABEL('IZSAMCERT')) -
RING(IZSAM_KEYRING) -
DEFAULT -
USAGE(PERSONAL))

RACDCERT ID(Userid-running-HSISANLO) -
CONNECT(ID(Userid-running-HSISANLO) CERTAUTH -
LABEL('Entrust Secure Server Root CA') -
RING(IZSAM_KEYRING) -
USAGE(CERTAUTH))

SETROPTS RACLIST(DIGTCERT,DIGTNMAP) REFRESH
/*
/*
//PERMIT EXEC PGM=IKJEFT01,DYNAMNBR=30
//SYSTSPRT DD SYSOUT=*
//SYSTSIN DD *
PROF NOPREF

RDEL FACILITY IRR.DIGTCERT.LIST
RDEL FACILITY IRR.DIGTCERT.LISTRING

RDEFINE FACILITY IRR.DIGTCERT.LIST UACC(NONE)
RDEFINE FACILITY IRR.DIGTCERT.LISTRING UACC(NONE)

PERMIT IRR.DIGTCERT.LIST CLASS(FACILITY) -
ID(Userid-running-HSISANLO) AC(READ)

PERMIT IRR.DIGTCERT.LISTRING CLASS(FACILITY) -

```

```

ID(Userid-running-HSISANLO) AC(READ)

SETR RACLIST(FACILITY) REFRESH
/*

/******
/*
/* To enable ZAO Analyzer to use HTTP secure (HTTPS) using an
/* existing CA certificate, 'Entrust Secure Server Root CA' in our
/* example, the following steps should be implemented by your site's
/* RACF Administrator:
/*
/* 1. Delete KEYRING(ZAO_KEYRING) and certificate with the
/* LABEL('ZAOCERT').
/* 2. Activate RACF Classes required for digital certificates.
/* 3. Define Keyring ZAO_KEYRING.
/* 4. Connect the existing CA certificate to the Keyring.
/* 5. Refresh RACF Classes required for digital certificates.
/* 6. Permit access to the Facility Class profiles.
/*
/*
/* The following JCL demonstrates a sample implementation:
/* 1. Update all occurrences of "Userid-running-HZASANLO" to reflect
/* your ZAO HTTPS environment.
/*
/* Do not change the RACF keyring 'ZAO_KEYRING' or label 'ZAOCERT'
/* unless you update the corresponding values in analyzer PARMLIB
/* member HZASANP2 and restart the Analyzer STC/Job.
/*-----*
//RACFDEF EXEC PGM=IKJEFT01,DYNAMNBR=30
//SYSTSPRT DD SYSOUT=*
//SYSTSIN DD *
PROF NOPREF

RACDCERT DELETE(LABEL('ZAOCERT'))
RACDCERT ID(CMACN) DELRING(ZAO_KEYRING)

SETROPTS CLASSACT(DIGTCERT,DIGTNMAP)
SETROPTS RACLIST(DIGTCERT,DIGTNMAP)

RACDCERT ID(Userid-running-HZASANLO) ADDRING(ZAO_KEYRING)

RACDCERT ID(Userid-running-HZASANLO) GENCERT -
SUBJECTSDN (CN('ZAOCERT')) -
OU('Your Dept.') -
C('US')) -
WITHLABEL('ZAOCERT')

RACDCERT ID(Userid-running-HZASANLO) -
CONNECT(ID(Userid-running-HZASANLO) -
LABEL('ZAOCERT')) -
RING(ZAO_KEYRING) -
DEFAULT -
USAGE(PERSONAL))

RACDCERT ID(Userid-running-HZASANLO) -
CONNECT(ID(Userid-running-HZASANLO) CERTAUTH -

```

```

LABEL('Entrust Secure Server Root CA') -
RING(ZAO_KEYRING) -
USAGE(CERTAUTH))

SETROPTS RACLIST(DIGTCERT,DIGTNMAP) REFRESH
/*
//PERMIT EXEC PGM=IKJEFT01,DYNAMNBR=30
//SYSTSPRT DD SYSOUT=*
//SYSTSIN DD *
PROF NOPREF

RDEL FACILITY IRR.DIGTCERT.LIST
RDEL FACILITY IRR.DIGTCERT.LISTRING
SETR RACLIST(FACILITY) REFRESH

RDEFINE FACILITY IRR.DIGTCERT.LIST UACC(NONE)
RDEFINE FACILITY IRR.DIGTCERT.LISTRING UACC(NONE)
SETR RACLIST(FACILITY) REFRESH

PERMIT IRR.DIGTCERT.LIST CLASS(FACILITY) -
ID(Userid-running-HZASANLO) AC(READ)

PERMIT IRR.DIGTCERT.LISTRING CLASS(FACILITY) -
ID(Userid-running-HZASANLO) AC(READ)

SETR RACLIST(FACILITY) REFRESH
/*

```

## Online login to the Analyzer

With the Analyzer reporting utility, you can log in with a browser to gain access to the Analyzer Asset, Discovery, and Administration reports and to any Custom reports that you create.

To access the Analyzer online, enter the URL including the host name and port number, in the address bar of a browser, for example `PTHOMU2.prod.hclpnp.com:9087`. In the Log In screen, provide the user ID and password associated with the BASIC security mode. See [Analyzer security on page 141](#).

IBM Z Software Asset Management
Log In  
Parameters

User Id:

Password:

When you login to the Analyzer online, the **Analyzer Menu** window includes the following tabs:

- The **Assets** tab contains reports that query high level aggregated data, such as product versions. This level of data is useful if you are reconciling product licenses.

**Analyzer Menu** | New Window | Logoff IZSAMADM

Assets | Discovery | Administration Reports | Administration | Custom

**Analyze high level aggregated data e.g. Product Versions**

<a href="#">Machine Inventory</a>	System z Machine inventory summary
<a href="#">Machine Resources</a>	Machine Resources
<a href="#">Product Inventory</a>	Product version inventory summary
<a href="#">Product Audit Trail</a>	Product version audit trail
<a href="#">Product Suites</a>	Product Suites
<a href="#">Product by System</a>	Cross reference of product versions per System
<a href="#">Product by Sysplex</a>	Cross reference of product versions per Sysplex
<a href="#">Product by System Group</a>	Cross reference of product versions per System Group
<a href="#">SCRT Tailored Fit Pricing</a>	SCRT Tailored Fit Pricing
<a href="#">Product by Repository</a>	Cross reference of product versions per Repository
<a href="#">Vendor Use by Month</a>	Cross reference of vendor products used per Month by System
<a href="#">Product Use by Month</a>	Cross reference of product versions used per Month by System
<a href="#">Product Use Trend</a>	Product version usage trend chart
<a href="#">Product Use by Machine</a>	Cross reference of product versions used per Machine
<a href="#">Product Use by Machine MSU</a>	Cross reference of product versions by Machine MSU capacity
<a href="#">Product Use by Machine and IBM Value Units</a>	Cross reference of product versions by Machine and Value Units
<a href="#">Registered Products</a>	Products Registered in Pamlib
<a href="#">Registered Product Usage</a>	Usage of Registered Products
<a href="#">Search by PID</a>	Search by PID and ISV ids
<a href="#">Search User Ids</a>	Search product version usage details for user ids
<a href="#">Search Job Names</a>	Search product version usage details for job names
<a href="#">Search Job Account Codes</a>	Search product version usage details for job account codes
<a href="#">Storage Subsystem Hardware</a>	Storage Subsystem Hardware

- The **Discovery** tab contains reports that query low-level discovery data, such as product releases, libraries, and modules. This level of data is useful if you support z/OS® systems.

**Analyzer Menu** | New Window | Logoff IZSAMADM

Assets | **Discovery** | Administration Reports | Administration | Custom

**Analyze low level discovery data e.g. Product Releases, Libraries, Modules**

<a href="#">GKR Summary</a>	Summary of products in the Global Knowledge Base catalog
<a href="#">GKR Discovery Summary</a>	Summary of products in the Global Knowledge Base catalog showing which products have been discovered
<a href="#">Discovered Product Summary</a>	Summary of discovered products
<a href="#">Discovered Product Detail</a>	Detail of discovered products
<a href="#">Discovered Product Audit Trail</a>	Audit trail of discovered products
<a href="#">Discovered Product by System</a>	Cross reference of discovered products per System
<a href="#">Discovered Product by Sysplex</a>	Cross reference of discovered products per Sysplex
<a href="#">Discovered Product by System Group</a>	Cross reference of discovered products per System Group
<a href="#">Discovered Product by Repository</a>	Cross reference of discovered products per Repository
<a href="#">Discovered Product Use by Month</a>	Cross reference of discovered products used per Month by System
<a href="#">End of Service Products</a>	Summary of discovered products that have a known End of Service date
<a href="#">Product Change Reports</a>	What has changed reports
<a href="#">Product Libraries</a>	Summary of discovered product libraries
<a href="#">Product Library Usage</a>	Summary of discovered product library usage
<a href="#">Deleted Libraries</a>	Show libraries that have been deleted
<a href="#">Volumes by System</a>	Summary of discovered library volumes by system
<a href="#">Dataset H.L.Q.s by System</a>	Summary of discovered dataset high level qualifiers by system
<a href="#">Libraries by System</a>	Summary of discovered libraries by system
<a href="#">Search by FMID</a>	Product Search by FMID
<a href="#">Module Compilers</a>	Module compiler versions
<a href="#">Search Libraries</a>	Search Libraries, with optional filters for library name mask and containing module name mask
<a href="#">Search Modules</a>	Search Modules, with optional filters for module name mask and library name mask
<a href="#">Job Use by Product Library</a>	Product release usage summary per Job name and Product Library
<a href="#">Usage Monitor File Detail</a>	Inspect usage detail in Usage Monitor raw data zip files or ZCAT zip files

- The **Administration Reports** tab contains administration tasks where no updates are permitted.



- The **Administration** tab contains administration tasks and troubleshooting reports. These reports are designed for IBM Z Software Asset Management administrators and users only see this menu if they are granted specific access.

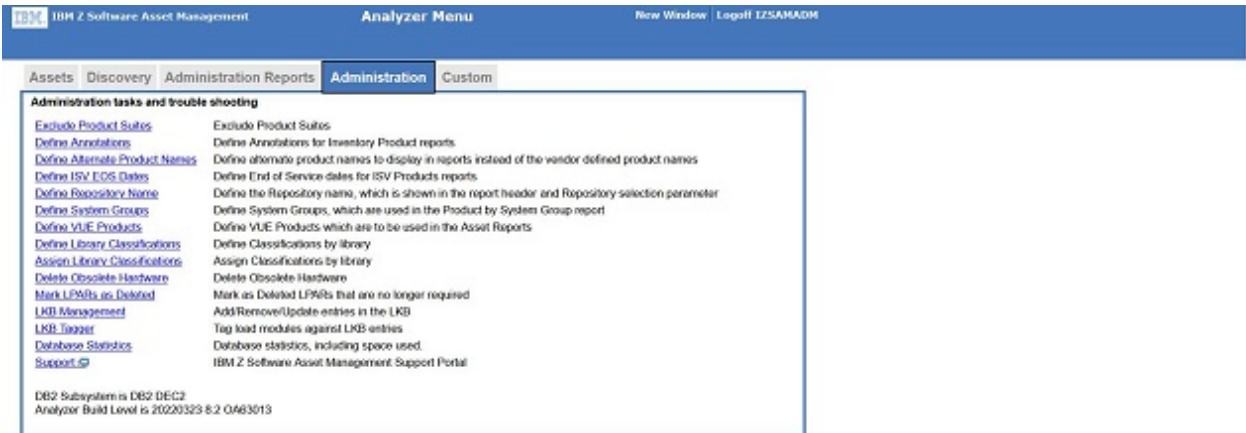

- The **Custom** tab contains your local custom reports. Two example custom reports are provided.

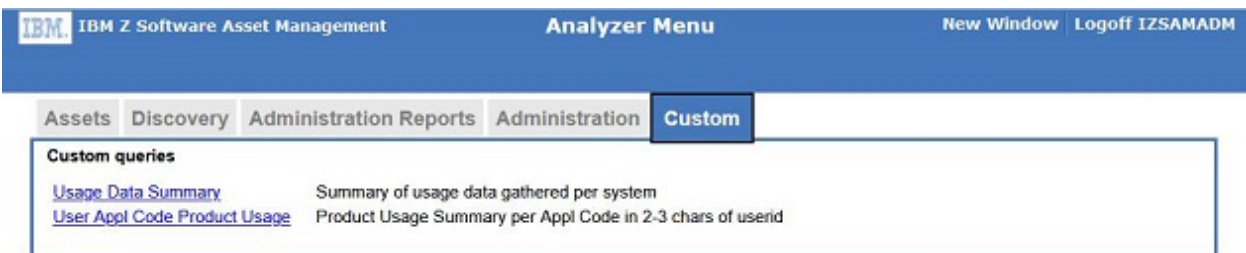

From any of the tabs, when you click the link to a report, the next window opens that contains parameter selection lists based on the data in your database. Select items in the parameter lists to construct a query. Hold down the Ctrl or Shift key to select multiple items from a list. When you have selected all required parameters, click **Submit** to run the query.

At the end of every report, the report name and parameters are shown in the same syntax that you can copy and paste into the HSISANLB batch job SYSIN DD deck to run the report in batch mode.

When you construct a query, if you choose the option Output format and select Browser as the output format, the report includes hyperlinks that you can use to drill down for more information.

You can download the content of a report, including the embedded content, in the following file formats:

- XML (xml)
- HTML (htm)

- Excel (Excel)
- Text (txt)
- Comma separated value (csv)

## Controlling the Analyzer address space

The Analyzer supports the STOP, REFRESH, and TRACE z/OS® modify commands.

**Table 22. z/OS® modify commands supported by the Analyzer**

Command	Description
STOP	<p>Stops the Analyzer address space. For example:</p> <pre style="background-color: #f0f0f0; padding: 5px;">/F HSISANLO,STOP</pre> <p>You can also use the z/OS® STOP command abbreviation:</p> <pre style="background-color: #f0f0f0; padding: 5px;">/P HSISANLO</pre>
REFRESH	<p>Refreshes Analyzer report templates and NLS text. For example:</p> <pre style="background-color: #f0f0f0; padding: 5px;">/F HSISANLO,REFRESH</pre> <p>This is typically used to load new Custom queries</p>
TRACE	<p>Toggles tracing on and off. For example:</p> <pre style="background-color: #f0f0f0; padding: 5px;">/F HSISANLO,TRACE</pre> <p>This should only be used when requested by IBM Support.</p>

## Running the Analyzer in batch mode

If you want to automate report generation, you can run the Analyzer in batch mode.

Here is a sample for running the job in a Db2 subsystem.

HSISANLB in JCLLIB contains sample JCL.

```
//HSISANLB JOB , 'IZSAM Analyz-Batch', REGION=0M,
// CLASS=A,MSGCLASS=X,MSGLEVEL=(1,1),NOTIFY=&SYSUID
/*JOBPARM SYSAFF=OMU2
/*MAIN SYSTEM=(OMU2)
/*Running in Environment DBTYPE=DB2
/*
/******
/* New in V8.2: **
/* SET OUTFMT=XML <= was previously "XLS" **
/* @headers <= new optional parameter (see example below) **
/* @headers = full <= displays report title, timestamp, list **
/* of parameters, and column headings **
/* @headers = title <= displays report title, timestamp and **
/* column headings **
/* @headers = none <= displays column headings only **
/* **
```

```

/* IZSAM Analyzer batch mode job:                **
/* a. Parameters are case sensitive              **
/* b. All parameters must start in column 1.    **
/* c. In OUTDSN, increase the size according to **
/* d. In WORK0, increase the size according to  **
/* WORK0 can be changed to a permanent dataset. **
/* e. In //TPARAM, setting TRACE = Y will force **
/* an Analyzer trace.                          **
/* Records are fetched and stored in the WORK0  **
/* file.                                        **
/* Once the fetch is complete, records are then **
/* physically written to the OUTDSN dataset, in  **
/* 8K blocks.                                  **
/******
// JCLLIB ORDER=(USERID.IZSAM82.DC2.TF12V8C2.JCLLIB)
/*
// SET OUTFMT=TXT
/* SET OUTFMT=XLS
/* SET OUTFMT=XML
/* SET OUTFMT=CSV
/* SET OUTFMT=HTM
/*
// SET OUTDSN=&SYSUID..IZSAMALZ.&OUTFMT Output dsn
/*
/***DELOLD EXEC PGM=IEFBR14
/***OUTDSN DD DSN=&OUTDSN,
/*** DISP=(MOD,DELETE),UNIT=SYSALLDA,SPACE=(TRK,(0,0))
/*
//ALLOC EXEC PGM=IEFBR14
//OUTDSN DD DISP=(MOD,CATLG),DSN=&OUTDSN,
// UNIT=SYSALLDA,SPACE=(CYL,(200,100),RLSE)
/*
/******
//ANALYZER EXEC PGM=HSICANLZ,REGION=0M,TIME=NOLIMIT
//STEPLIB DD DISP=SHR,DSN=DB2VC10.DEC2.SDSNEXIT
// DD DISP=SHR,DSN=DB2.VC10.SDSNLOAD
// DD DISP=SHR,DSN=hlq.SHSIMOD1
// DD DISP=SHR,DSN=CEE.SCEERUN
// DD DISP=SHR,DSN=CBC.SCLBDLL
//SYSPRINT DD SYSOUT=*,LRECL=500
//HSIANL1 DD DISP=SHR,DSN=hlq.SHSIANL1
//HSIANL2 DD DISP=SHR,DSN=hlq.SHSIANL2
//HSICUST DD DISP=SHR,
// DSN= USERID.hlq.DC2.TF12V8C2.PARMLIB(HSISANCQ)
/*HSINLS DD DISP=SHR,DSN=hlq.SHSIANL1(HSINLSJP)
//DSNAOINI DD DISP=SHR,
// DSN=USERID.hlq.DC2.TF12V8C2.PARMLIB(HSISCLI)
//WORK0 DD DSN=&WORK0,DISP=(NEW,DELETE),
// UNIT=SYSALLDA,SPACE=(CYL,(200,100),RLSE)
//TPARAM DD DUMMY
//OUTPUT1 DD DISP=OLD,DSN=&OUTDSN,LRECL=2000
//APPSTATS DD SYSOUT=*,LRECL=1000
//APPTRACE DD SYSOUT=*
//SYSIN DD *
/asset/audit_trail
vendor = IBM
showfeature = on
multirep = REPZ8

```

```

@headers = full
/*

//HZASANLB JOB 'ZAO Analyzer-Batch',REGION=0M,
// CLASS=A,MSGCLASS=X,MSGLEVEL=(1,1),NOTIFY=&SYSUID
/*JOBPARM SYSAFF=OMU2
/*MAIN SYSTEM=(OMU2)
/*Running in Environment DBTYPE=DB2
/*
/******
/*
/* ZAO Analyzer batch mode job: **
/* a. Parameters are case sensitive **
/* b. All parameters must start in column 1. **
/* c. In OUTDSN, increase the size according to report output. **
/* d. In WORK0, increase the size according to report output. **
/* WORK0 can be changed to a permanent dataset, if required. **
/* e. In //TPARAM, setting TRACE = Y will force an Analyzer trace. **
/* **
/* Records are fetched and stored in the WORK0 file. **
/* Once the fetch is complete, records are then physically written **
/* to the OUTDSN dataset, in 8K blocks. **
/* **
/* @headers <= optional parameter (see example below) **
/* @headers = full <= displays report title, timestamp and **
/* list of parameters **
/* @headers = title <= displays report title and timestamp only **
/* @headers = none <= displays column headings only **
/* **
/******
// JCLLIB ORDER=(ZAOHLQ.ZAOV12.DEC2.TFZAORC2.JCLLIB)
/*
// SET OUTFMT=TXT
/* SET OUTFMT=XML
/* SET OUTFMT=CSV
/* SET OUTFMT=HTM
/*
// SET OUTDSN=&SYSUID..ZAOANLZ.&OUTFMT Output dsn
/*
/**DELOLD EXEC PGM=IEFBR14
/**OUTDSN DD DSN=&OUTDSN,
/** DISP=(MOD,DELETE),UNIT=SYSALLDA,SPACE=(TRK,(0,0))
/*
//ALLOC EXEC PGM=IEFBR14
//OUTDSN DD DISP=(MOD,CATLG),DSN=&OUTDSN,
// UNIT=SYSALLDA,SPACE=(CYL,(5,5))
/*
/******
//ANALYZER EXEC PGM=HZACANLZ,REGION=0M,TIME=NOLIMIT
//STEPLIB DD DISP=SHR,DSN=DB2VC10.DEC2.SDSNEXIT
// DD DISP=SHR,DSN=DB2.VC10.SDSNLOAD
// DD DISP=SHR,DSN=HZADEV.V110.SHZAMOD1
// DD DISP=SHR,DSN=CEE.SCEERUN
// DD DISP=SHR,DSN=CBC.SCLBDLL
//SYSPRINT DD SYSOUT=*,LRECL=500
//HZAANL1 DD DISP=SHR,DSN=HZADEV.V110.SHZAANL1
//HZAANL2 DD DISP=SHR,DSN=HZADEV.V110.SHZAANL2
//HZACUST DD DISP=SHR,

```

```

// DSN=ZAOHLQ.ZAOV12.DEC2.TFZAORC2.PARMLIB(HZASANCQ)
/*HZANLS DD DISP=SHR,DSN=HZADEV.V110.SHZAANL1(HZANLSJP)
//DSNAOINI DD DISP=SHR,
// DSN=ZAOHLQ.ZAOV12.DEC2.TFZAORC2.PARMLIB(HZASCLI)
//WORK0 DD DSN=&WORK0,DISP=(NEW,DELETE),
// UNIT=SYSALLDA,SPACE=(CYL,(100,50),RLSE)
//TPARAM DD DUMMY
//OUTPUT1 DD DISP=OLD,DSN=&OUTDSN,LRECL=2000
//APPSTATS DD SYSOUT=*,LRECL=1000
//APPTRACE DD SYSOUT=*
//SYSIN DD *
/asset/audit_trail
vendor = IBM
showfeature = on
multirep = TFZAREPZ
@headers = full
/*

```

The report name and parameters are specified in the SYSIN DD and the output goes to the OUTPUT1 DD.

The simplest way to know what report name and parameters to specify is to run the report first using Analyzer in online mode. At the end of every report, the report name and parameters are listed in the syntax needed for batch mode. You can copy and paste this syntax into the batch SYSIN DD.

Alternatively, you can directly type in the parameters. Wildcard filters have been enabled to assist in this case.

# Chapter 8. Running the utilities provided with IBM Z Software Asset Management

IBM Z Software Asset Management provides utilities that you run to perform routine functional tasks to maintain the product lifecycle.

## Condensing usage data with the ZCAT utility

The ZCAT utility concatenates and condenses Usage Monitor data sets and generates a file that is then processed by the Usage Import program. When you condense the data produced by the Usage Monitor program, you can save storage space and improve the performance of the Usage Import program.

The Usage Monitor started task produces at least one usage data set per day. You can design a work flow that runs the ZCAT utility on the data sets on a weekly, fortnightly, or monthly basis before the Usage Import program processes them. Running the ZCAT utility on a weekly basis is useful, but depends on the amount of data that is produced and processed at your site. The Usage Monitor program collects detail about which job, account ID, and user ID are using each module of a particular library on a specified date. This information is output into multiple files that are produced on a daily basis. The ZCAT utility condenses the files in the following manner:

- Usage data across multiple files is condensed to a monthly granularity, as are the records stored in the Repository database.
- Redundant records in files and records that are not stored in the database, are omitted.
- Optionally, condensation can apply to user IDs, job names, or account ID details.
- The ZCAT output file is compressed and ready to be transmitted for Usage Import processing.

The following diagram shows the syntax of program parameters to run the ZCAT utility.

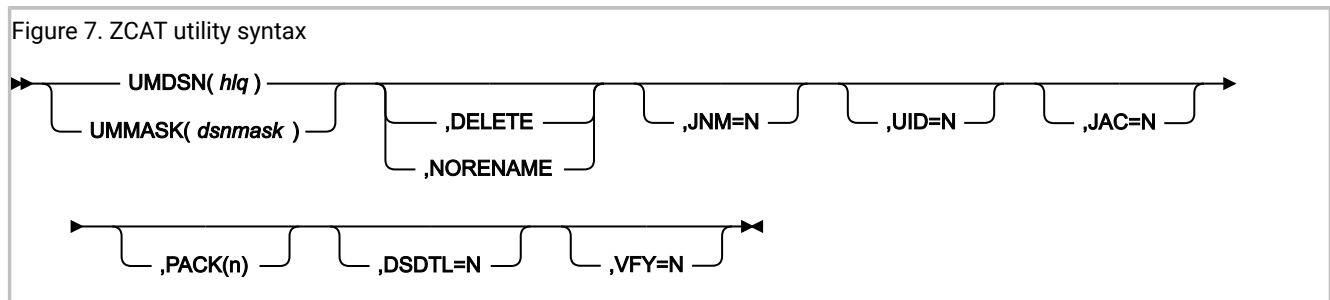

### Catalog search parameters

UUMDSN and UMMASK are mutually exclusive. One must be specified if the ZCAT0001 DD is not allocated.

#### UUMDSN(hlq)

*hlq* is the Usage Monitor data set high-level qualifier. When the **UUMDSN** parameter is specified, ZCAT concatenates all data sets having names of *hlq*.Dyyyyddd.Thhmmssst where *yyyyddd* and *hhmmssst* are the timestamp patterns of data sets produced by the Usage Monitor. The *hlq* can contain wildcard characters of percent or asterisk. The percent character denotes a single character mask, and the asterisk character denotes

all characters. For example UMDSN(hlq.\*\*\*) would search for all data set names of hlq.\*\*.D%.T%.%.

### UMMASK(*dsnmask*)

*dsnmask* is the full dsn mask search criteria. It can be used to search for a pattern of files that differ from the files produced by the Usage Monitor. This parameter is useful if the files produced by the Usage Monitor have been renamed, but still need processing. Specifying UMMASK(hlq.D%.T%.%) is equivalent to specifying UMDSN(hlq)



**Note:** An easy way to remember the difference between UMDSN and UMMASK is to remember that UMDSN can accept the data set name prefix value specified in the Usage Monitor DSN setting, whereas UMMASK requires a mask which will match the entire data set name.

Input data sets found by searching the catalog may be zipped or unzipped. If zipped, then records before the first Usage Monitor header record will be discarded. If unzipped, the data set will not be processed unless the first record is a Usage Monitor header record.

## Data set disposition parameters

One or more optional parameters can follow the mandatory parameters.

### DELETE

Delete the input data sets after the output data set is successfully generated. **NODELETE** is the default.

### NORENAME

Do not rename input data sets from hlq.D\*.T\* to hlq.D\*.S\* after the output data set is successfully generated. The default is to rename these input data sets to stop them being reprocessed by the ZCAT utility. Use this option only to rename the data sets before further ZCAT processing. This option stops double counting of usage data. This parameter is automatically set when UMMASK is used.

**RENAME** must not be explicitly specified with **DELETE**.

Data sets allocated to the ZCAT0001 DD are not included in **RENAME** and **DELETE** processing.

## Optional condensation parameters

Improvements in performance and data storage space are gained by using the ZCAT utility options to carry out further condensation of data, ignoring data differences that are not important at your site, and do not appear in your regular reporting. You can still point the Usage Monitor File Detail Report to the saved archive of the Consolidated detail file (ZCATDETL), or to the Usage Monitor output files. ZCATDETL is produced by the ZCAT utility.

### JNM

JNM is used to condense data based on job names.

JNM=N - Condense different job names to generic names of -STC-, -JOB-, -TSO- or -SYS-

JNM=Y - Preserve collected job name.

The shipped version of the HSISZCAT sample job specifies Y.

## UID

UID is used to condense data based on user IDs.

UID=N - Replace collected user identifiers with blanks.

UID=Y - Preserve collected user identifiers.

The shipped version of the HSISZCAT sample job specifies Y.

## JAC

JAC is used to condense data based on job account codes.

JAC=N - Replace collected job account codes with blanks.

JAC=Y - Preserve collected job account codes.

The shipped version of the HSISZCAT sample job specifies Y.



**Note:** The ZCATDETL file can be used to collect all valid importable input records into a single data set for archiving purposes, with the exception that duplicate user records are suppressed, and all user records are discarded if **UID=N** is specified.

## Optional control parameters

### DSDTL

DSDTL is used to control data set statistics reporting.

DSDTL=Y - Report data set condensation statistics to SYSPRINT.

DSDTL=N - Suppress the reporting of data set condensation statistics.

### VFY

VFY is used to control whether the ZCATOUT file is to be verified after creation.

VFY=Y - After the ZCATOUT file is complete, it will be unzipped and read to verify that its contents are readable and that the expected number of records are present. This is the default.

VFY=N - Bypass ZCATOUT verification processing.

### PACK

PACK is used to specify the zip compaction level used when writing zipped data.

PACK=n - where *n* is a decimal digit in the 0 to 9 range.

PACK=0 - Specifies that the **shrink** zip algorithm is used while higher values specify the compaction level of the **deflate** zip algorithm to be used. Higher compaction levels will achieve greater data compression, but will also consume disproportionately more CPU time.

PACK=1 - Is the default setting which requests the fastest level of the **deflate** method.

## DD statements

### SYSPRINT

Specifies the report file required by ZCAT which is usually allocated to SYSOUT. By default, RECFM=VBA and LRECL=137 will be used, though these can be overridden within some limits.

### ZCATOUT

Specifies the name of the ZCAT output data set. This data set can then be used as the input to the Usage Import program, where usage details are imported into the database. If the ZCATOUT DD card is omitted, ZCAT by default writes to a data set having the name hlq.Dyyyyddd.Uhhmmsst (U instead of T implied by the high level qualifier (hlq) option for input data sets), where yyyyddd and hhmsst refer to the date and time timestamp of the first processed input data set. If dynamically allocated, SPACE=(TRK,(768,255),RLSE) is used.

### ZCATDETL

If the ZCATDETL DD is allocated, the uncondensed data is written to this data set. This allows detailed job name, user ID and job account information to be retained for subsequent analysis and/or reference. Any diagnostic records and records that fail validity testing are not written. Duplicate user records are suppressed. If UID=N is specified then all user records are discarded.

The ZCATDETL and ZCATOUT data sets are compressed data sets written by the ZCAT utility. SMS compression is not supported for these data sets.

### ZCAT0001

If the ZCAT0001 DD is allocated, it specifies one or more usage data zip archives to be processed by ZCAT. ZCAT0001 is processed after any data sets located by searching the catalog, and allows administrators to manually process specific data sets which may have fallen outside the usual processing regime, or may not fit any convenient data set name mask. Like dynamically allocated input data sets, data set(s) allocated to ZCAT0001 may be zip archives or may contain unzipped data. However, ZCAT0001 is treated by ZCAT as a single file, and a concatenation containing both zipped and unzipped data is not allowed.

```
//ZCAT EXEC PGM=HSIZCAT,PARM='UMDSN(hlq.**)'
//STEPLIB DD DISP=SHR,DSN=hsi.SHSIMOD1
//ZCATOUT DD DSN=&SYSUID..hlq.ZCATOUT,
// DISP=(NEW,CATLG),UNIT=SYSDA,SPACE=(CYL,(50,50),RLSE),
// DCB=(DSORG=PS,RECFM=VB,LRECL=27994,BLKSIZE=27998)
//ZCATDETL DD DSN=&SYSUID..hlq.ZCATDETL,
// DISP=(NEW,CATLG),UNIT=SYSDA,SPACE=(CYL,(50,50),RLSE),
```

```
// DCB=(DSORG=PS,RECFM=VB,LRECL=27994,BLKSIZE=27998)
//SYSPRINT DD SYSOUT=*,HOLD=YES

//ZCAT EXEC PGM=HAZCAT,PARM='UMDSN(hlq.**)'
//STEPLIB DD DISP=SHR,DSN=hza.SHZAMOD1
//ZCATOUT DD DSN=&SYSUID..hlq.ZCATOUT,
// DISP=(NEW,CATLG),UNIT=SYSDA,SPACE=(CYL,(50,50),RLSE),
// DCB=(DSORG=PS,RECFM=VB,LRECL=27994,BLKSIZE=27998)
//ZCATDETL DD DSN=&SYSUID..hlq.ZCATDETL,
// DISP=(NEW,CATLG),UNIT=SYSDA,SPACE=(CYL,(50,50),RLSE),
// DCB=(DSORG=PS,RECFM=VB,LRECL=27994,BLKSIZE=27998)
//SYSPRINT DD SYSOUT=*,HOLD=YES
```

In this example, all data sets having names of hlq.\*.D%%%%%.T%%%%%hlq.\*.D%%%%%.T%%%%% are processed due to the **UMDSN** parameter. The condensed output is written to sysuid.hlq.ZCATOUTsysuid.hlq.ZCATOUT where the SYSUID system symbol is the user ID of the person submitting the job. This file is then transmitted for Usage Import processing. All valid records are written to the ZCATDETL DD card, sysuid.hlq.CATDETLsysuid.hlq.CATDETL, which is then archived for reference purposes.

## Deleting usage data with the Usage Deletion utility

Use the Usage Deletion utility to delete detailed, summarized, and aggregated usage data for a specified period for all systems in the repository. Each time you run the utility, usage data is aggregated to update the asset tables.

To minimize space utilization and improve SQL query performance, keep no more than three months of detailed module usage data and 13 months of aggregated product usage data.

If you do not run the Usage Deletion utility for some time, select a period of a few months, in order to keep the run times down to a reasonable time.

In the previous release, audit records from the TLOGUI table are also deleted by this utility. In the current release, these audit records are no longer deleted by this utility.

An audit table captures information of this utility when it is run, and these audit records can be browsed using an Analyzer report. As part of housekeeping, obsolete audit records from this utility are deleted by the MDEL Deletion utility, together with audit records from other utilities.

### Running the Usage Deletion utility

To run the Usage Deletion, use the job HSIUDELE, in the JCLLIB. This job is generated from the HSISCUST post-installation customization job.

**TPARAM parameters****COMMIT=**

Default is 1000. Number of records stored before issuing of COMMIT.

**DSN=**

Db2® location. Value assigned, as defined in job HSISCUST.

**KEEPDETAIL=**

Default is 2. Number of months prior to the current month for which detailed and summarized module usage data are kept. KEEPDETAIL=0 means all detailed and summarized module usage data excluding those from the current month are deleted.

**KEEPAGGR=**

Default is 12. Number of months prior to the current month for which aggregated product usage data are kept. KEEPAGGR=0 means all aggregated product usage data, excluding those from the current month are deleted.

**FIRSTDATE=**

Start of the first date range. This is in the form YYYYMM. Only complete months are chosen.

**LASTDATE=**

End of the last date range. This is in the form YYYYMM.



**Note:** The date range of deletion is inclusive of the month specified in the FIRSTDATE and LASTDATE parameters.

**REPSHEMA=**

Repository qualifier. Name of qualifier is &REPZSCHM.

**SID=**

System Identifier of system for which usage should be deleted. Specify SID=ALLSIDS to delete usage data for all SIDs.



**Note:** If KEEPDETAIL is set to a value, then FIRSTDATE / LASTDATE will be ignored. If detailed usage data are to be deleted within a certain date range, then comment out KEEPDETAIL and define dates for FIRSTDATE / LASTDATE. For further details, please see comments described in job HSISUDEL.

## Deleting a specific system with the System Deletion utility

Use the System Deletion utility to delete discovery, usage, and hardware data for a specified system.

For example, you can also use the System Deletion utility to delete a system that was accidentally imported into the repository, or to delete a system that is decommissioned.

An audit table captures information of this utility when it is run, and these audit records can be browsed using an Analyzer report. As part of housekeeping, obsolete audit records from this utility are deleted by the MDEL Deletion utility, together with audit records from other utilities.

### Running the System Deletion utility

To run the System Deletion, use the job HSISLDEL, in the JCLLIB. This job is generated from the HSISCUST post-installation customization job.

#### TPARAM parameters

**DSN=**

Db2® location. Value assigned, as defined in job HSISCUST.

**REPSHEMA=**

Repository qualifier. Name of qualifier is &REPZSCHM.

**SID=**

System Identifier of system to be deleted.

## Deleting obsolete data with the Physical Deletion utility

Use the Physical Deletion utility to delete obsolete data that are no longer required.

Over time, data that have been collected are either superseded or no longer valid, thus taking up space in the repository. Each time, you run this utility, obsolete data for the specified period are physically deleted for all systems in the Repository.

To keep the run time down to a reasonable time, set the date range for a smaller period.

An audit table captures information of this utility when it is run, and these audit records can be browsed using an Analyzer report. As part of housekeeping, obsolete audit records from this utility are deleted by the MDEL Deletion utility, together with audit records from other utilities.

This utility deletes obsolete records from the following tables:

- TLIBRARY
- TLIBSYS
- TMODULE
- TCSECT
- TPOVLIB
- TPRODUCT
- TVENDOR
- TVERSION

## Running the Physical Deletion utility

To run the Physical Deletion, use the job HSISPDEL, in the JCLLIB. This job is generated from the HSISCUST post-installation customization job. Refer to comments in the job on how to run an SQL statement to list date ranges for deletion.

### TPARAM parameters

#### COMMIT=

Default is 1000. Number of records stored before issuing of COMMIT.

#### DSN=

Db2® location. Value assigned, as defined in job HSISCUST.

#### FIRSTDATE=

Start of the first date range. This is in the form YYYYMM. Only complete months are chosen.

#### LASTDATE=

End of the last date range. This is in the form YYYYMM.



**Note:** The date range of deletion is inclusive of the month specified in the FIRSTDATE and LASTDATE parameters.

#### REPSHEMA=

Repository qualifier. Name of qualifier is *&REPZSCHM*.

## Deleting obsolete audit records with the MDEL Deletion utility

Use the MDEL Deletion utility to delete obsolete IQ audit records that are no longer required.

During IQ Import, Usage Import and housekeeping utilities, audit records are collected. Over time, these obsolete records need to be deleted if they are no longer referenced. This utility deletes obsolete records from the following audit tables:

- TLOGIQ
- TLOGUI
- TLOGAGGR
- TLOGLDEL
- TLOGPDEL
- TLOGUDEL

In addition, this utility also deletes obsolete records from these two tables:

- TCHANNEL\_PATH
- TCONTROL\_UNIT

## Running the MDEL Deletion Utility

To run the MDEL Deletion, use the job HSISMDEL, in the JCLLIB. This job is generated from the HSISCUST post-installation customization job.

### TPARAM parameters

#### DSN=

Db2® location. Value assigned, as defined in job HSISCUST.

#### REPSHEMA=

Repository qualifier. Name of qualifier is *&REPZSCHM*.

#### RETENTION=

Default is 24. Number of months prior to the current month for which IQ audit records are kept.

#### SID=

Default is ALLSIDS. System Identifier of system to be deleted.

## Listing high-level qualifiers for the Usage Monitor utility

IBM Z Software Asset Management collects large amounts of usage data. The High-level Qualifier Listing for the Usage Monitor utility creates a list of high-level qualifiers for the products that are to be identified.

Following are some examples that exclude all usage, but include some usage for the specified high-level qualifiers:

```
XDS(*)
IDS(DB2.*)
IDS(IMS.*)
IDS(CICS.*)
IDS(SYS1.*)
```

The high-level qualifier listing process is automated in the Inquisitor Import job. The high-level qualifier listing is written to a data set, and this data set is concatenated to the *HSIZIN* control file for the Usage Monitor program.

### Running the High-level Qualifier Listing for the Usage Monitor utility

To run the High Level Qualifier for the Usage Monitor utility, use the job HSISLLST in the JCLLIB. This job is generated from the HSISCUST post-installation customization job.

### TPARAM parameters

#### DSN=

Db2® location. Value assigned, as defined in HSISCUST.

#### REPSHEMA=

Repository qualifier. Name of qualifier is *&REPZSCHM*.

## Updating the TPARAM table

The TPARAM table in the repository can be set to an inconsistent state due to failures in jobs that update the repository tables. You can reset a parameter in the TPARAM table to rectify this inconsistent state.

To run the TPARAM table update, use the job HSISTPRM, in the JCLLIB. This job is generated from the HSISCUST post-installation customization job.

### SYSIN parameter

```
UPDATE &REPZSCHM.TPARAM SET FVALUE = '0' WHERE FKEY = 'PROCRUN';
```

## Tagging unidentified products with the Product Tagging utility

The Product tagging utility allows you to create local entries for your in-house software in the Local Knowledge Database. It is not intended for creating IBM or ISV software, as this may cause unpredictable results. If you need to add products or versions that are not being identified, then notify IBM Support, so that they can then update the GKB. On certain occasions, IBM Support may consider your request to add IBM or ISV software to the LKB database, but contact them first before doing so.



**Note:** Using options from the Administration tab of the Analyzer is the preferred method for updating and managing the contents of the Local Knowledge Base (LKB). Use of the Analyzer will ensure that the LKB is not updated in a logically inconsistent way. In order to continue creating program tag data with the Tagger in batch, supply a program parameter of TAGNOW or OLDTAG. Also note that this tag data will not be collected by the Inquisitor unless the OLDTAG keyword is present in the program parameter string passed to the HSIPINQ program.

## Product tagging process

Product tagging is a manual process where you must provide the product name, the vendor, and the location of the programs. The Product Tagging utility uses the same method as the Inquisitor program to scan the programs and records the results in dedicated program members.

The `SYSIN` file contains the control statements that describe which licensed programs are to be tagged. This file contains the program name, vendor name, product identifier, and product version. The program library which contains the software to be tagged is allocated to the `SYSLIB` file.

You can have only one set of identifying attributes for each program name. If conflicting attributes are found for one or more program names, the Product Tagging utility issues a message and stops.

Information about all discovered programs relating to the nominated product is compiled into a single object module. This module is written to the scanned library allocated to `SYSLIB` file or to the program library allocated to the optional `HSIREDIR` file. Using the `HSIREDIR` file, you can nominate to keep all tag data separate from licensed program software. The `HSIREDIR` file data sets must be included in the standard Inquisitor scan processing, even if these data sets contain no other program.

The tag data members created by the Product Tagging utility are recognized by the Inquisitor (by their SSI value) during normal program library scanning. The Inquisitor program extracts the tag data from the member contents and writes it to an output file. The Inquisitor import process uses these program tags to maintain entries for the programs in the local knowledge base. The match engine can then accurately identify the tagged product level, regardless of which library the product is deployed to and which system the data is collected from.

Each time you run the Product Tagging utility, it scans a single library and tags a single software product, or optional feature of a product. For products with multiple program libraries, each library is processed in a separate job or step. To ensure effective software identification by the match engine as it processes each library, use the `OPTION` statement to differentiate the identification entities between the different libraries of a product. Do not tag distribution libraries.

You can override the default output member name of `@HSIPTAG` by specifying a `TAGMEM` statement. All output members from the Product Tagging utility are flagged with an SSI value of `X'D7E3C1C7'`, which is 'PTAG' in EBCDIC.

If there is no preexisting member of the same name, the Product Tagging utility creates a new program member to contain the tag data. If a member exists, the new tag data is added to the existing data that relates to other products or optional features. Any data relating to the same software identified by `{VENDOR + PRODUCT + OPTION + VERSION}` is replaced. The data relating to each software piece resides in its own control section. Tag data members contain no executable code, and are bound with the only loadable attribute. These data members are bound as reentrant, with a residence mode of `ANY`, to minimize the impact of being placed in a library which is loaded into the Link Pack Area.

To erase the effects of processing with the Product Tagging utility, delete the tag data members which are identified by their SSI value. If you are using ISPF, employ the **`SORT SSI`** member list command.

The software processed when you run the Product Tagging utility has a key of `{VENDOR + PRODUCT + OPTION + VERSION}`. If non-key data items, such as the values specified in the `PPNUM` or `LICENSED` statements are incorrect, you can correct them by fixing the input statement values and rerunning the utility. This action replaces all non-key tag data. However, if a key data item is incorrect, it will not be erased by running the Product Tagging utility with the correct data.

If you are processing libraries that are not dedicated to a single licensed program, use member name masking to prevent tagging programs not related to that product. Some installations place multiple software products in a combined common library. If the products are tagged before they are combined, you must use different tag data member names.

## Product tagging job and control statements

You use the `HSISPTAG` job in the `JCLLIB` to run the Product Tagging utility. This job is generated from the `HSISCUST` post-installation customization job. You input control statements using the `SYSIN` file.

General syntax rules are:

- Fixed length, variable length, and undefined record formats are processed.
- Short records are extended to 72 bytes of data, with blanks if necessary.
- Only the first 72 bytes of data for each record are processed by the Tagger.
- Records beginning with an asterisk are treated as comments and do not alter continuation status.
- The first non-blanks of a statement must identify the statement type.

- One or more blanks must follow the statement type.
- A statement with no value or operand specified is invalid.
- For statement types other than SELECT, the specified value is deemed to start with the first non-blank after the statement type name.
- Statements can be placed in any order. All statements are processed before any tagging activity commences.
- SELECT is the only statement type which can be supplied more than once in an input file.
- SELECT is the only statement type which can be continued over more than one record.

The following table lists all of the statement types that you can use with the Product Tagging utility:

**Table 23. Product Tagging utility statement types**

Statement Type	Value	Default Value	Required	Maximum length
VENDOR	Vendor name	-	Yes	30 bytes
PRODUCT	Product name	-	Yes	50 bytes
PPNUM	Licensed program number	blanks	No	16 bytes
OPTION	Optional feature name	BASE	No	30 bytes
VERSION	Software level	-	Yes	8 bytes
LICENSED	Separately licensed feature? (YES or NO)	NO	No	3 bytes
TAGMEM	Output member name	@HSIPTAG	No	8 bytes
SELECT	Program name filter	PGM(*)	No	8 bytes per mask

SELECT is not a value-oriented statement type. It has operands which have values specified in parentheses. The PROGRAM or PGM inclusion operand can be abbreviated to P. The XPROGRAM or XPGM exclusion operand can be abbreviated to XP.

The Tagger stops parsing a SELECT record and the current statement continues on to the next record whenever a continuation character is encountered. Valid continuation characters are plus and hyphen. A continuation cannot occur within an operand name, or a value mask.

Figure 8. SELECT syntax

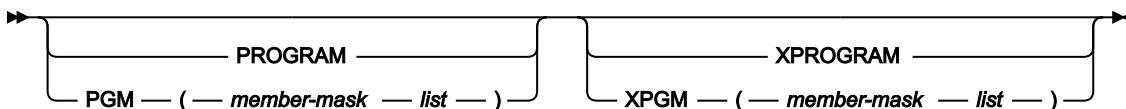

**member-mask**

A string up to 8 bytes in length, representing one or more possible member names of a PDS or PDSE. Use a percent sign to indicate that any single character is to be considered a match in the exact location of the compared character string. Use an asterisk to indicate that any zero or more characters are a match.

## Product tagging examples

Three examples are provided to show the ways that you can use the Product Tagging utility to tag unidentified products.

### Example 1

A company called ISV has created a build of several programs (build 97) it is developing under the Swisho4U brand. The data sets created by this build have their own disk volume called BLD097. The tag data is to be redirected to a data set dedicated for this purpose.

```
//STEP1 EXEC PGM=HSITAGP
//SYSPRINT DD SYSOUT=*
//SYSLIB DD DSN=S4U.LOADLIB,DISP=SHR,UNIT=3390,VOL=SER=BLD097
//HSIREDIR DD DSN=S4U.TAGLIB,DISP=SHR
//SYSIN DD *
VENDOR ISV
PRODUCT Swisho4U
VERSION BUILD097
/*
```

### Example 2

The BigBiz Inc. data center is about to deploy the contractor data processing component for Version 4 Release 2 of its internally developed human resources application called HU-MAN. The software is tagged in its own library, but the default tag member name is not used in case it is later loaded into a program library common to several applications. All programs in HU-MAN have names beginning with HU, but the contractor component is the only component which has program names beginning with HUC. The relevant program library can be accessed by using the catalog.

```
//TAGRUN EXEC PGM=HSITAGP
//SYSPRINT DD SYSOUT=*
//SYSLIB DD DSN=HUMAN.V4R2M0.LOAD,DISP=SHR
//SYSIN DD *
VENDOR BIGBIZ INCORPORATED
PRODUCT HU-MAN Human Resources Management
OPTION Contractor Handling
VERSION 04.02.00
TAGMEM HUMANT@G
SELECT PGM(HUC*)
/*
```

### Example 3

Version 1.5 of the product MVSBL0AT from MiscWare has been deployed on a system which has a dedicated tag data library called SYS2.TAGLIB. Link list programs for the product have been placed in SYS2.LINKLIB and ISPF application modules have been placed in SYS2.ISPLLIB. The product does not have optional features, but only the base component installed. All the installed programs have names beginning with MVSBL. The OPTION statement is used to ensure that the contents of each library can be identified by the Match Engine.

```
//STEP1 EXEC PGM=HSITAGP
//SYSPRINT DD SYSOUT=*
```

```
//SYSLIB DD DSN=SYS2.LINKLIB,DISP=SHR
//HSIREDIR DD DSN=SYS2.TAGLIB,DISP=SHR
//SYSIN DD *
VENDOR MiscWare
PRODUCT MVSBLOAT
OPTION BASE (Batch)
VERSION 01.05.00
TAGMEM $$OEMTAG
SELECT PGM(MVSB*)
/*

//STEP2 EXEC PGM=HSITAGP
//SYSPRINT DD SYSOUT=*
//SYSLIB DD DSN=SYS2.ISPLLIB,DISP=SHR
//HSIREDIR DD DSN=SYS2.TAGLIB,DISP=SHR
//SYSIN DD *
VENDOR MiscWare
PRODUCT MVSBLOAT
OPTION BASE (Dialogs)
VERSION 01.05.00
TAGMEM $$OEMTAG
SELECT PGM(MVSB*)
/*
```

## Importing subcapacity reporting data with the SCRT Import utility

The SCRT Import utility imports data (CSV files) which are generated from the IBM Subcapacity Reporting Tool. The import tool now also supports the importing of Tailored Fit Pricing (TFP) data. New reports to show TFP data are available in the Analyzer under the Asset tab.

### Running the SCRT Import utility

To run the SCRT import utility, use the job HSISSCRT in the JCLLIB. This job is generated from the HSISCUST post-installation customization job.

### Data input

DDNAME CSVIN contains the CSV output from the IBM® SCRT tool which can be from a data set with DSORG of PS or PO. Binary uploaded CSV files are supported. DDNAME SIDMAP maps duplicate SMFIDs to a unique SID. The SCRT Import utility handles data where the same SMFID is used on multiple machines concurrently.

To support Multiplex reports, the IBM SCRT Tool needs to be 25.3.1 or higher.

### Data input example

Map SMFID on specific machines to your desired SID. As described in this example, when processing data for CPU serial 11111, SMFID IP01, use SID QIP1, and so on.

```
//SIDMAP DD *
11111-IPO1=QIP1
11111-IPO2=QIP2
11111-IPO3=QIP3
/*
```

**CPU serial**

5 alphanumeric characters

**SMFID**

1 to 4 alphanumeric characters

**Unique SID**

1 to 4 alphanumeric characters. This must be the same as the SID value being used by the Usage Monitor for that z/OS® system.

**Data output**

Several Db2® tables are populated from the data contained in CSVIN, including NODE, NODE\_CAPACITY, and PRODUCT\_NODE\_CAPACITY. Ensure that the CSVIN DD points to the .CSV output file created by the SCRT tool. This may be a DSORG=PO or PS data set.

**TPARAM parameters****COMMIT=**

Default is 1000. Number of records stored before issuing a COMMIT.

**DSN=**

Db2 location. Value assigned, as defined in job HSISCUST.

**GKBSHEMA=**

Global Knowledge Base qualifier for z/OS. Name of qualifier is &GKBZSCHM\_GKB7.

**REPSHEMA=**

Repository qualifier. Name of qualifier is &REPZSCHM.

## Extracting data with the XML Export utility

The XML Export utility extracts information in XML format that you can then import into IBM Control Desk (ICD).

The extracted information can be either:

- A catalog of the products that are installed in your system.
- A catalog of the products defined in the Global Knowledge Base (GKB).

**Running the XML Export utility**

To run the XML export utility, use the job HSISKBT, in the JCLLIB. This job is generated from the HSISCUST post-installation customization job.

The output XML file generated from this utility needs to be transferred by FTP to a distributed environment and then loaded into IBM Control Desk (ICD). The XML file must be translated from EBCDIC to ASCII.

**TPARAM parameters****SSID=**

Db2® subsystem name. Value assigned, as defined in job HSISCUST.

**SCHEMA=**

Repository qualifier or Global Knowledge Base qualifier.

- a) Using the Repository qualifier value means that a catalog of products installed on your site is selected.
- b) You can also use the Global Knowledge Base qualifier value. This would mean that a catalog of all products defined in the Global Knowledge Base is selected.

**Transferring output XML by FTP**

The output XML file that is generated when you run the XML Export utility must be transferred by FTP to a distributed environment before you can load it into IBM Control Desk (ICD).

**Procedure**

1. To connect to the host system, in a command line, enter the following command:

```
C:\temp ftp host name
```

2. When prompted, enter your user name and password.
3. To set the input to ASCII format, enter the following command:

```
ftp > quote type a
```

4. To transfer non-ASCII characters, enter an ENCODING command before you enter the GET command:

```
quote site ENCODING=MBCS MBDATACONN=(IBM-939,UTF-8)
```

This example specifies encoding for a Japanese code page.

5. To specify the location of the file to transfer, enter the following command:

```
ftp > get 'hsiinst.SWKBT.XML' C:\XML.FILE
```

6. To complete the FTP transfer, enter the following command:

```
ftp > exit
```

**Loading data into a staging table (for Db2® only)**

Use this utility to load data from a UMON/ZCAT file into the TSTAGE table. Once the TSTAGE table is populated, the data can be browsed using an Analyzer report.

**Data input**

DDNAME INSTAGE contains the UMON or ZCAT file. The file can either be a zipped or unzipped file. Only a single UMON/ZCAT file is allowed as input.

## Running the loading utility

To run the loading utility, use the job HSISSSTAG in the JCLLIB. This job is generated from the HSISCUST post- installation customization job.

### TPARAM parameters

#### COMMIT=

Default is 1000. Number of records stored before issuing of COMMIT.

#### DSN=

Db2® location. Value assigned, as defined in job HSISCUST.

#### REPSHEMA=

Repository qualifier. Name of qualifier is *&REPZSCHM*.

## Compressing and decompressing data sets with the HSIZIP utility

HSIZIP is a utility program that can compress a sequential or partitioned data set into a zip archive, decompress the contents of a zip archive into a sequential or partitioned data set, and report on the contents of a zip archive.

In this context, an archive is a sequential file that contains one or more logical files for the purpose of reducing the space occupied by the data. The archive can serve as a backup and convenient transport format for the data it contains. The Inquisitor and Usage Monitor components usually create zip archives to contain the data that they collect.

The HSIZIP utility has two compress and decompress functions: one for text data, and one for binary data.

### Text data processing with the HSIZIP utility

The HSIZIP utility processes text data to be compatible with the zip processing utilities available on other platforms.

When compressing a text record, the HSIZIP utility performs the following processing:

- Translates EBCDIC line feed (LF) characters (x'25') to periods.
- Translates EBCDIC data to ASCII data.
- Appends an ASCII carriage return line feed (CRLF) sequence (x'0D0A') to encode the record extent.
- Compresses the data and writes it to the archive.

Each compressed member is marked as an ASCII text file, and the internal attribute value of the central file header is set to 1.

The following input data set attributes are also stored in the zip header extended field:

- Data set organisation
- Record format
- Block size
- Logical record length

When decompressing text data, the HSIZIP utility performs the following processing:

- Accumulates data until an ASCII LF (x'0A') is encountered.
- Truncates the trailing ASCII carriage return (CR) (x'0D') if present in accumulated data.
- Translates the ASCII data to EBCDIC and writes the data as a single record.

During compression, records read from data sets with fixed-length records have their trailing blanks truncated before being compressed. After being decompressed, short records to be written to data sets with fixed-length records are extended with blanks to the required length.

The translation tables used for conversion between EBCDIC and ASCII that are originally sourced from the EZAESENU member in the SEZATCPX library are reciprocal, so that applying one translate table and then the other yields the original data. Consequently, all EBCDIC single byte character set (SBCS) and double byte character set (DBCS) text can undergo a ZIP and UNZIP cycle without corruption.

## Binary data processing with the HSIZIP utility

The HSIZIP utility processes binary data in order to preserve record boundaries, while other platforms typically consider binary data to be a byte stream without structure.

When compressing a record of binary data, the HSIZIP utility performs the following processing:

- So that record boundaries can be preserved, the following is done depending on the input record format:
  - For fixed-length records, no additional data preparation is done.
  - For variable-length records, the record descriptor word (RDW) is retained as part of the data.
  - When the record format is undefined, each block is prefixed by an RDW where the first two bytes contain the length of the block including the RDW, and the third and fourth bytes contain zeros.
- Compresses the data and writes it to the archive.

Each compressed member is marked as a binary file and the internal attribute value of the central file header is set to 0.

The following input data set attributes are also stored in the zip header extended field:

- Data set organisation
- Record format
- Block size
- Logical record length

When decompressing binary data, the HSIZIP utility performs the following processing:

- To establish the length of the record, the following is done depending on the record format of the original input data set:
  - For fixed-length records, the original record length is used.
  - For other record formats, 4 bytes from the archive are decompressed and examined to determine if they form a valid RDW. If so, the RDW length indication is used, and if not, then the data is treated as a byte stream where record boundaries do not need to be preserved.
- Data is decompressed and written as a record of the determined length. Maximum-length records are written when the data is assessed to be a byte stream.

During decompression of binary data, the embedded RDWs are checked for validity. If an RDW does not indicate a positive length greater than 4 or does not end with two bytes of zeros, the HSIZIP utility switches to byte stream mode. In byte stream mode, the utility considers data as a stream of bytes without an inherent record structure. If the RDW that fails the validity test is the first four bytes of the file, the resultant decompression is broadly compatible with the decompression that most other platforms perform and the utility issues an informational message. If the RDW that fails the validity test is not at the start of the file, the utility issues a warning message, sets the final condition code to be greater than zero, but continues processing so that the output data is available for any necessary data recovery activity.

## HSIZIP program parameters

The HSIZIP utility can accept up to two program parameters. The first parameter specifies the function the program is to perform and the second parameter can provide a data definition override list for programs that dynamically invoke the utility.

When you invoke the HSIZIP utility as a stand-alone batch program, the PARM value on the EXEC statement specifies the functional request. DD statements define the details of the following files:

- The SYSPRINT report file
- The SYSUT1 input file
- The SYSUT2 output file

You can specify program parameters in the function request in mixed case. The following information describes valid program parameters.

### **none**

If you omit the program parameter, usage notes will be printed to SYSPRINT and LIST processing will be initiated. If SYSUT1 is not allocated the program completion code will be set to 1.

### **LIST**

If you specify this parameter, the utility produces a list of the entries in the central file directory.

### **TEST**

This function will list the local file headers as well as the entries in the central file directory, check that the stored and actual values of some properties match, then perform a trial unzip of each file in the zip archive.

**ZIP or ZIP=filename.ext**

Use this parameter to compress a sequential data set into a new archive with a single constituent file assigned the name specified in the parameter. If no name is specified in the parameter, the name **seq.txt** is used. The data is treated as text.

**ZIP or ZIP=\*.ext**

Use this parameter to compress a partitioned data set into a new archive where each member is loaded as a separate zipped file within the archive. The PDS member name is used to name each corresponding archive member. If an asterisk and a file extension are specified, then the file extension will be appended to the name of the zipped version of each real PDS member. The data is treated as text.

**ADD or ADD=filename.ext**

Use this parameter to compress a sequential data set into an existing archive. A new archive member will be created with the name specified in the parameter. If no name is specified in the parameter, the name **seq.txt** is used. The data is treated as text. There is no dependency on the text or binary nature of files already present in the archive. To retain data access, ensure that all resultant archive member names are unique.

**ADD or ADD=\*.ext**

Use this parameter to compress a partitioned data set into an existing archive where each member is loaded as a separate zipped file within the archive. The PDS member name is used to name each corresponding archive member. If an asterisk and a file extension are specified, then the file extension will be appended to the name of the zipped version of each real PDS member. The data is treated as text. There is no dependency on the text or binary nature of files already present in the archive. To retain data access, ensure that all resultant archive member names are unique.

**UNZIP or UNZIP=filenamemask**

Use this parameter to decompress an archive into a partitioned data set and load each zipped file into a separate member. The parameter restores data sets from archives made by the HSZIP utility with **PARM=ZIP**. If the output data set is sequential, only the first file in the archive is unzipped. You can use the file name mask specification to filter the files to be unzipped.

**ZIPBIN or ZIPBIN=filename.ext**

Use this parameter to compress a sequential data set into a new archive with a single constituent file assigned the name specified in the parameter. If no name is specified in the parameter, the name **seq.bin** is used. The data is treated as binary and no translation is performed.

**ZIPBIN or ZIPBIN=\*.ext**

Use this parameter to compress a partitioned data set into a new archive where each member is loaded as a separate zipped file within the archive. The PDS member name is used to name each corresponding archive member. If an asterisk and a file extension are specified, then the file extension will be appended to the name of the zipped version of each real PDS member. The data is treated as binary and no translation is performed. There is no dependency on the text or binary nature of files already present in the archive.

**ADDBIN or ADDBIN=filename.ext**

Use this parameter to compress a sequential data set into an existing archive. A new archive member will be created with the name specified in the parameter. If no name is specified in the parameter, the name seq.bin is used. The data is treated as binary and no translation is performed. There is no dependency on the text or binary nature of files already present in the archive. To retain data access, ensure that all resultant archive member names are unique.

**ADDBIN or ADDBIN=\*.ext**

Use this parameter to compress a partitioned data set into an existing archive where each member is loaded as a separate zipped file within the archive. The PDS member name is used to name each corresponding archive member. If an asterisk and a file extension are specified, then the file extension will be appended to the name of the zipped version of each real PDS member. The data is treated as binary and no translation is performed. There is no dependency on the text or binary nature of files already present in the archive. To retain data access, ensure that all resultant archive member names are unique.

**UNZIPBIN or UNZIPBIN=filenamemask**

Use this parameter to decompress an archive into a partitioned data set and load each zipped file into a separate member. The parameter restores data sets from archives made by the HSIZIP utility with **PARM=ZIPBIN**. If the output data set is sequential, only the first file in the archive is unzipped. Use the file name mask specification to filter the files to be unzipped.

The filenames and filename masks that you specify in program parameters must not exceed 128 bytes in length. File name mask matching is case insensitive. The following characters are generic masking characters for filename masks:

- ? (question mark) matches any single character.
- \* (asterisk) matches any zero or more contiguous characters.

If the function request is absent or invalid, the utility writes usage notes to the report file. If the request is absent, the utility attempts to run the LIST function.

**Controlling zip compaction**

For the program parameter values described above, wherever the parameter begins with the characters **ZIP** or **ADD**, the values **ZPn** or **ADn** can be substituted respectively, where **n** is a decimal digit in the 0 to 9 range which specifies the compaction that the zip process is to use.

A value of 0 specifies that the **shrink** method is to be used, which is the method the HSIZIP program always used in releases prior to Version 8 Release 2.

A value in the 1 to 9 range specifies the corresponding compaction level of the **deflate** method. As the compaction level number increases, so does both the data compression and the CPU time consumed by the zip process.

The default is the fastest **deflate** compaction level. That is, **PARM=ZIP** is equivalent to **PARM=ZP1** and **PARM=ADD** is equivalent to **PARM=AD1**.

## HSIZIP files

The HSIZIP utility uses the following files:

- SYSPRINT is a report file. RECFM=VBA and LRECL=137 are used in the DCB.
- SYSUT1 is an input file that describes the data set that contains data to be zipped or the zip archive that contains data to be listed or unzipped.
- SYSUT2 is an output file that contains the results of a compression or a decompression operation. This file is not required by the LIST and TEST functions.

The HSIZIP utility does not support spanned records for any file. The main compression and decompression input and output to archive files uses the queued sequential access method (QSAM) locate mode. Apart from the lack of support for spanned records, an input archive allocated to SYSUT1 can have any valid record format and reside on any device that can be read by QSAM. An archive allocated to SYSUT2 must have variable-length records and support update-in-place processing. In effect, a SYSUT2 file must be an MVS DASD data set that is not also a compressible extended-format data set.

## Dynamic invocation of the HSIZIP program by other programs

Other programs can call the HSIZIP utility to perform compression and decompression processing requests. When the HSIZIP utility receives control, it examines the program parameter list and proceeds accordingly.

The first program parameter must begin with a halfword counter indicating the length of the function request text that immediately follows. The format is the same format as the system uses to pass the parameter specified in the PARM operand of the EXEC statement in JCL.

A second program parameter can be specified to override the default file names used by the HSIZIP utility. If the value of the halfword length indicator at the start of the parameter is not a multiple of 8 or is not less than 256, the HSIZIP utility ignores it. A series of 8-byte file name entries immediately follow the length indicator and each can specify the DD name to use instead of the default name. Set a slot to 8 bytes of zeros to avoid overriding that particular default file name. SYSPRINT, SYSUT1 and SYSUT2 correspond to the sixth, eighth and ninth file name slots respectively.

## HSIZIP data set support

The data control block (DCB) attributes of the original data set that the HSIZIP utility compresses are stored in zip header fields where possible, but the information is not used to supply output data set attributes during unzip processing. The success of a compress and decompress cycle requires the user to supply suitable DCB attributes for the ultimate destination of the data.

The following points are provided to help you to assess whether the HSIZIP utility can successfully process a data set:

- When processing a whole partitioned data set, the file name specified after **ZIP=** or **ADD=** is ignored, unless it begins with an asterisk followed by a period, when it becomes a file extension specification.
- When ZIP processing detects that a PDS member is a zip archive or a GIF file, the member is stored as a byte stream as is without attempting further compression or record boundary preservation.

- ZIPBIN processing of PDS members containing zip archives usually causes the compressed size to be larger than the uncompressed size, due to the inability to further compact the data and the insertion of RDWs to preserve record boundaries. So, if the only non-text data in a PDS is in members which are themselves zip archives, specify ZIP rather than ZIPBIN to minimize the resultant file size.
- When using ADD or ADDBIN, avoid duplicate file names in the resultant archive.
- You can use the ADD and ADDBIN parameters to create an archive with a mixture of text and binary file members.
- The binary or text nature of an unzip process is set by the program parameter and not from the attribute values in the file header.
- When the HSIZIP utility creates a zip archive, the data set name of the input file is stored as the zip archive comment.
- PDS member user data such as system status information (SSI), ISPF statistics, and load module attributes are stored in the comment field of the central file header of the archive member and can be restored during unzip operations.
- Alias members are stored as files with zero bytes. The alias member data is preserved only if the real member associated with the alias member is also processed.
- Use ZIPBIN and UNZIPBIN when processing load module libraries.
- The HSIZIP utility cannot restore program PDSE data sets because only the program binder can write to program PDSEs. There is no restriction on data PDSEs.

## HSIZIP return codes

When you run the HSIZIP utility, several codes are returned that indicate whether the program ran successfully.

**Table 24. HSIZIP utility return codes**

Return code	Description
0	Request processed successfully.
1	Usage notes were printed and the SYSUT1 DD was not allocated.
2	Warning message issued. The warning is for a condition that does not affect the operation of the current request, but will probably impact on the intended use of the file created by the request.
4	No data was found to process, or an I/O error was encountered.
8	An error occurred. Look at SYSPRINT for more details.
Other	As set by another routine. Look at SYSPRINT for more details.

## Browsing zipped data

Components such as the Inquisitor programs, the Usage Monitor, and the ZCAT utility deal with sequential data sets containing zip archives. Processing the data with a zip algorithm allows the same information to be conveyed in a fraction of the original size, but it does mean that browsing the file to quickly confirm the nature of its content becomes a more involved process.

One advantage of a file browser over an editor is that the browser can quickly present the data from the start of a file for inspection without reading in the whole data set, whereas editors typically read the complete data contents before

proceeding. Similarly, a data set containing zipped data could be unzipped with the result being browsed in the usual way, but this means that space for all the unzipped data is required which tends to defeat the purpose of compressing the data.

### Browsing zipped data using HSIBRZIP

The HSIBRZIP program can be used to browse the unzipped contents of a data set without requiring the unzipping of the entire data set. A REXX EXEC called HSIIBRWZ is shipped in the SHSIEXECSHZAEXEC library to provide a convenient interface to invoke the HSIBRZIP program.

To make the facility available for use, customize the HSIIBRWZ EXEC and place it in a suitable library giving it a suitable member name. (When installing it into your local library, you can call it HSIIBRWZ, or you can give it a simpler name, such as BRZIP or whatever you find suitable.) The customization process consists of supplying the data set name of the program library containing the HSIBRZIP program.

HSIBRZIP invokes the BRIF service of ISPF, and so it requires an ISPF environment for execution. The HSIIBRWZ EXEC expects an operand of a data set name, and so is suitable for general use under ISPF including as a line command in a data set list created by option 3.4.

HSIBRZIP only unzips enough data to be able to provide the records selected by the user for browsing. For example, if there are ten million records but the user only scrolls down to view the first hundred records in the browse session, then only 100 records need to be unzipped. Unzipped records are staged in a data space so that scroll up requests can be satisfied by providing records from the data space without the need to interrupt the current progress of the suspended unzip process. The unzip process is resumed when previously unread records need to be accessed.

HSIBRZIP has several limitations and behavioural characteristics:

- All zipped data is assumed to be ASCII text, and is translated to EBCDIC before display.
- The maximum record length without wrapping on to a new line is 1024 bytes.
- The name passed to BRIF to display as the file name is the name of the first or only file in the zip archive.
- If the end of a file is reached, before showing data from the next file, HSIBRZIP will insert a record containing the following message:

```
{ HSIBRZIP reached end of file - Start of file newname }
```

where *newname* is the name of the next file being unzipped from the same archive.

- If HSIBRZIP recognizes records as having come from the Inquisitor or the Usage Monitor then it will insert records into the browse data to provide column headings for data items within the recognized records. Such inserted lines will be repeated whenever the record type is different from the previous record, and will have the following form:

```
{ details This line was inserted for display by HSIBRZIP }
```

where *details* describes items present in the subsequent record(s).

- HSIBRZIP cannot present data that would cause it to read more records than can be stored in the data space, either because local limits failed a data space extend request, or because of the 2 gigabyte size limit of data spaces.

## Browsing active collection data

The Usage Monitor collects program usage information and writes out the collected data at least once each day. Once the data is in a data set, it is possible to browse it to determine if some expected usage was collected or not. Sometimes it would be advantageous to be able to determine if expected data collection has taken place without waiting for the collection cycle to end, either at the expected time or because it was triggered manually to facilitate data access.

### **Browsing active collection data using HSIIZEEK**

The HSIIZEEK program provides a way of accessing data in the active collection repository. It writes a report to the HSIIZEEK DD which can be directed to SYSOUT or to a sequential data set. The HSIIZEEK file has fixed-length records with an LRECL set by the HSIIZEEK program. The record length depends on the items being reported and so is subject to change, but is currently 289 bytes. HSIIZEEK can be run in a batch job step or in a TSO session.

The HSIIZEEK REXX EXEC is shipped in the SHSIEXEC library and when executed presents the data from HSIIZEEK in an ISPF Browse session. Before using HSIIZEEK customize it by supplying the data set name of the program library containing the HSIIZEEK program, and store the EXEC with a suitable member name in your local REXX EXEC library.

The contents of the HSIIZEEK file are not a documented programming interface. However, the first section of the report contains one line for each detail usage record that will be written by the writer task at the end of the collection cycle, and so a simple FIND command in an HSIIZEEK ISPF Browse session can tell you whether usage for a specific program has been detected in the current collection cycle so far or not. You can find program library data set name and job name details on the same report line.

IBM Technical Support may ask for information from HSIIZEEK reports while investigating and diagnosing problems.

## Verifying database changes since the product was released

This utility verifies database changes that were introduced after the product was released.

To run the verification, use job HSIIZEEK in the JCLLIB. This job is generated from the HSIIZEEK post-installation job.

# Chapter 9. Configuring language support

Z Software Asset Management includes Japanese language support for MVS™ Message Service (MMS) message information. You can also configure the Analyzer utility to create and view reports in Japanese.

## Configuring Japanese messages

To configure messages in the Japanese language, there are two areas to customize. You must compile the Japanese language MMS messages, and then you must enable messages in the Japanese language in the Language Environment®.

### About this task

Japanese language MMS message information is contained in the hsi.SHSIMJPN program directory. You must compile the message file and then install the most recent system runtime message file. The HSISMCMP job in the JCLLIB library compiles MMS messages. This job is generated by the HSISCUST post-installation customization job.

### Procedure

1. Run the HSISMCMP job to compile the MMS files into a system runtime message file, for example the `hsi.MMSJPN99` file.

The HSISMCMP job is generated by the HSISCUST post-installation customization task.

2. Create an entry named **MMSLSTJ9** in the z/OS® PARMLIB library, with the following values:

```
DEFAULTS LANGCODE(JPN)
LANGUAGE LANGCODE(JPN) DSN(SYS2.MMSJPN99) CONFIG(CNLJPN00)
```

3. Enter the following MVS™ system command to install the system runtime message file:

```
SET MMS=J9
```

4. Enable Japanese messages for the Inquisitor Import and the Usage Import, Summary, and Deletion components.

To configure the language environment, refer to the following documents:

- For information about the Language Environment® MSGFILE and NATLANG options, refer to the *Language Environment® Programming Reference (SA227562)*.
- For information about specifying Language Environment® runtime options, refer to the *Language Environment® Programming Guide (SA227561)*.
- For information about setting NATLANG(JPN) as an installation default, refer to the *Language Environment® Customization (SA22-7564)*.

## Enabling the Analyzer utility for Japanese

You can configure the Analyzer utility so that you can view and create reports in Japanese.

### Procedure

1. In the Analyzer HSIJANLO started task, update the DD statements with the following commands:

```
//HSICUST hsi.SHSIPARM(HSISANCJ)
//HSINLS hsi.SHSIANL1(HSINLSJP)
```

2. Perform the following tasks to customize your Japanese Analyzer reports:

- a. Copy the hsi.SHSHIPARM(HSISANCJ) parameter to the hsiinst.PARMLIB(HSISANCJ) library.
- b. Modify the hsiinst.PARMLIB(HSISANCJ) library to customize your reports.
- c. Enter the following command to update the Analyzer HSIJANLO started task:

```
//HSICUST hsiinst.PARMLIB(HSISANCJ)
```

## Configuring the Japanese Db2® subsystem for use with IBM Z Software Asset Management

### About this task

IBM Z Software Asset Management is implemented with a Japanese Db2® subsystem that is configured with the MCCSID=939 code page (Japanese extended English).

If your Db2® for z/OS® system is configured with MCCSID=930, MCCSID=1390, or MCCSID=5026 code page (Japanese extended Katakana), additional customization is required to set up IBM Z Software Asset Management .

For Katakana codepage, data for lower case characters (a,b,c,d,...z) are stored differently in the databases. For example:

- c = x'83' for Latin-based codepage
- c = x'64' for Katakana codepage

In Katakana, the hex definitions for lower case characters are different from Latin-based codepages.

In IBM Z Software Asset Management , some columns have data stored in lower case. As a result, there are extra considerations in managing the conversion of data for lower case characters. In addition, module names in the GKB Knowledge Base for z/OS (not GKB Knowledge Base for z/OS UNIX System Services), are in encoded format – meaning some of the encoded characters are in lower case characters.

For consistency in IBM Z Software Asset Management , if the Db2® subsystem is defined in the Katakana code page, then all lower case characters must be stored in the Katakana format (value of 'c' must be stored as x'64').

When setting up a Db2® subsystem to support EBCDIC double byte CCSID (coded character set identifiers), in the Db2® for z/OS installation job (DSNTIJUZ), parameter MIXED is set to 'YES' and parameter MCCSID defined with different values (default value is a 65534). Here is an example from DSNTIJUZ:

```
DSNHDECM CHARSET=KATAKANA
```

- ASCCSID=1041
- AMCCSID=942
- SCCSID=290
- MCCSID=930 (1390 or 5026)
- GCCSID=300
- USCCSID=367
- UMCCSID=1208

- UGCCSID=1200
- ENSCHEME=EBCDIC
- APPENSCH=EBCDIC
- ENSCHEME=EBCDIC
- APPENSCH=EBCDIC
- DATE=ISO
- DATELEN=0
- DECARTH=DEC15
- DECIMAL=PERIOD
- DEF\_DECFLOAT\_ROUND\_MODE=ROUND\_HALF\_EVEN
- DEFLANG=IBMCOB
- DELIM=DEFAULT
- IMPLICIT\_TIMEZONE=CURRENT
- MIXED=YES

You must perform additional customization in IBM Z Software Asset Management .

Customization are as follows:

## Procedure

1. Bind Call Level Interface ODBC/CLI.

Create a new CLI plan name for IBM Z Software Asset Management and bind it using ENCODING(939).



**Note:** By default, IBM Z Software Asset Management utilizes the Db2® supplied DSNACLI plan name

Create a copy of db2.SDSNSAMP(DSNTIJCL), and run the bind with the new definitions.

The example below is for Db2® z/OS V12.

```
Change COLLID from DSNAOCLI ==> DSNAOCLT
//SYSTSIN DD *
  DSN SYSTEM(????)

  BIND PACKAGE (DSNAOCLT) MEMBER(DSNCLIC1) -
    ENCODING(939)
  BIND PACKAGE (DSNAOCLT) MEMBER(DSNCLIC2) -
    ENCODING(939)
  BIND PACKAGE (DSNAOCLT) MEMBER(DSNCLIF4) -
    ENCODING(939)
  BIND PACKAGE (DSNAOCLT) MEMBER(DSNCLIMS) -
    ENCODING(EBCDIC) SQLERROR(CONTINUE)
    ENCODING(939)
  BIND PACKAGE (DSNAOCLT) MEMBER(DSNCLIQR) -
    ENCODING(939)
  BIND PACKAGE (DSNAOCLT) MEMBER(DSNCLICR) -
    ENCODING(939)
  BIND PACKAGE (DSNAOCLT) MEMBER(DSNCLINF) -
    ENCODING(939)
```

```

BIND PLAN(DSNACLIT)      -
  PKLIST(DSNAOCLT.DSNCLIC1  -
    DSNAOCLT.DSNCLIC2      -
    DSNAOCLT.DSNCLIF4      -
    DSNAOCLT.DSNCLIMS      -
    DSNAOCLT.DSNCLIQR      -
    DSNAOCLT.DSNCLICR      -
    DSNAOCLT.DSNCLINF      ) -
ENCODING(939)
END
    
```

2. Update the ODBC Initialization file.

The ODBC initialization file can be found in members:

PARMLIB (HSISCLI) and PARMLIB (HSISCLIT).

Do the following in members HSISCLI and HSISCLIT:

- a. Uncomment parameter CURRENTAPPENSCH in the "COMMON" section.
- b. Replace the value for PLANNAME from DSNACLI to DSNACLIT in the "SUBSYSTEM" section.

Here is an example on updating the two values:

```

; COMMON section
CURRENTAPPENSCH=939
;
; SUBSYSTEM section
DSN
MVSATTACHTYPE=CAF
PLANNAME=DSNACLIT
    
```

3. Update the following PARMLIB members to include the "CCSID (1027,939,300)" entry for all "LOAD DATA" statements:

HSISSQ06

HSISSQ12

HSISSQ29

For example in PARMLIB (HSISSQ29):

```

LOAD DATA INDDN TPARAM LOG YES REPLACE
  CCSID (1027,939,300)
  INTO TABLE TFGKBZ9_IQF7.TPARAM (
FKEY      POSITION( 1: 64) CHAR(64),
FVALUE    POSITION( 65:318) CHAR(254))

LOAD DATA INDDN TCOMPILE LOG YES REPLACE
  CCSID (1027,939,300)
  INTO TABLE TFGKBZ9_IQF7.TCOMPILERS (
FCOMPID   POSITION( 3: 17) CHAR(15),
FCOMPNAME POSITION( 18: 47) CHAR(30))

LOAD DATA INDDN TIQFILTR LOG YES REPLACE
  CCSID (1027,939,300)
    
```

```

      INTO TABLE TFGKBZ9_IQF7.TIQFILTERS (
FOWNER      POSITION( 3: 3) CHAR(1),
FIQFILTER    POSITION( 4: 58) CHAR(55),
FLPARNAME    POSITION( 59: 62) CHAR(4))

LOAD DATA INDDN TXPCMODU LOG YES REPLACE
      CCSID (1027,939,300)
      INTO TABLE TFGKBZ9_IQF7.TXPCMODULES (
FOWNER      POSITION( 2: 2) CHAR(1),
FMODNAME    POSITION( 3:256) CHAR(254))

LOAD DATA INDDN TXPCSPEC LOG YES REPLACE
      CCSID (1027,939,300)
      INTO TABLE TFGKBZ9_IQF7.TXPCSPEC (
ID          POSITION( 2: 5) INTEGER,
FLIST      POSITION( 6: 55) CHAR(50))

LOAD DATA INDDN TXVENDOR LOG YES REPLACE
      CCSID (1027,939,300)
      INTO TABLE TFGKBZ9_IQF7.TXVENDORS (
FOLDVENDORNAME POSITION( 2: 65) CHAR(64),
FNEWVENDORNAME POSITION( 66: 95) CHAR(30))

```

#### 4. Bind the Db2 DSNREXX plan.

Following are the implementation steps:

- a. Create a copy of db2.SDSNSAMP(DSNTIJTM). This copy should just contain the DSNREXX job step.
- b. Update the job by replacing parameter ENCODING (EBCDIC) with ENCODING (939). See example below:
- c. Run the modified DSNTIJTM job. DSNREXX plan should now have ENCODING (939).

Example:

```

DSN SYSTEM(DSN)
BIND PACKAGE(DSNREXX) MEMBER(DSNREXX) ACTION(REPLACE)
ISOLATION(CS)-
  LIBRARY('DB2V12.SDSNDBRM')-
  VALIDATE(BIND) CURRENTDATA(NO)-
  ENCODING(939)
BIND PACKAGE(DSNREXUR) MEMBER(DSNREXX) ACTION(REPLACE)
ISOLATION(UR)-
  LIBRARY('DB2V12.SDSNDBRM')-
  VALIDATE(BIND)-
  ENCODING(939)
BIND PACKAGE(DSNREXCS) MEMBER(DSNREXX) ACTION(REPLACE)
ISOLATION(CS)-
  LIBRARY('DB2V12.SDSNDBRM')-
  VALIDATE(BIND) CURRENTDATA(NO)-
  ENCODING(939)
BIND PACKAGE(DSNREXRS) MEMBER(DSNREXX) ACTION(REPLACE)
ISOLATION(RS)-
  LIBRARY('DB2V12.SDSNDBRM')-
  VALIDATE(BIND)-
  ENCODING(939)
BIND PACKAGE(DSNREXRR) MEMBER(DSNREXX) ACTION(REPLACE)
ISOLATION(RR)-
  LIBRARY('DB2V12.SDSNDBRM')-
  VALIDATE(BIND)-

```

```

ENCODING(939)
BIND PLAN(DSNREXX) -
  PKLIST(*.DSNREXX.DSNREXX, -
    *.DSNREXUR.DSNREXX, -
    *.DSNREXCS.DSNREXX, -
    *.DSNREXRS.DSNREXX, -
    *.DSNREXRR.DSNREXX) -
  ACT(REP) ISO(CS) CURRENTDATA(YES) SQLRULES(DB2) -
  ENCODING(939)
RUN PROGRAM(DSNTIAD) PLAN(DSNTIA12) -
  LIB('DB2V12.RUNLIB.LOAD')

```

## Configuring the Turkish Db2 subsystem for use with IBM Z Software Asset Management

If Db2 for z/OS is configured with SCCSID=1026, additional customization is required in setting up IBM Z Software Asset Management.

### About this task

#### Procedure

1. Update the ODBC initialization file.

The ODBC initialization file can be found in members:

PARMLIB (HSISCLI) and PARMLIB (HSISCLIT)

In the COMMON section, add parameter CURRENTAPPENSCH=37 for both members - HSISCLI and HSISCLIT

```

; COMMON section
CURRENTAPPENSCH=37
;

```

2. Update the following PARMLIB members to include the "CCSID (37)" entry for **ALL** "LOAD DATA" statements:

(HSISSQ06)

(HSISSQ12)

(HSISSQ29)

Here is an example for (HSISSQ06):

```

LOAD DATA INDDN TPARAM LOG NO NOCOPYPEND RESUME
NO REPLACE
CCSID (37)

```

```
INTO TABLE &GKZSCHM_GKB&.TPARAM(
```

3. Run HSISGKBL to load GKB data with these new LOAD definitions.

# Chapter 10. Reference information for IBM Z Software Asset Management

Reference information includes messages, repository table layouts, and performance and tuning.

## Repository table layouts

This topic describes the tables in the Repository including column names, types, and length.

**Table 25. NODE**

Column name	Column type	Column length	Description
NODE_KEY	Char	32	Global Unique ID (GUID) for this entry
NODE_TYPE	Char	4	Entry Type: HW or LPAR
HW_TYPE	Char	4	System z® Hardware Type, for example 2096
HW_MODEL	Char	3	System z® Hardware Model, for example P03
HW_PLANT	Char	2	System z® Hardware Plant, for example 02
HW_SERIAL	Char	12	System z® Hardware Serial, for example. 000000013EED
HW_NAME	Char	10	Configured Hardware Name
HW_VENDOR	Char	10	System z® Hardware Vendor, for example IBM
LPAR_NUMBER	Integer		Logical Partition Number, for example 1
LPAR_NAME	Char	10	Logical Partition Name, for example LPARSYS1
VMGUEST_NAME	Char	10	z/VM® Guest Name (if z/OS® is running under z/VM®)
HW_NODE_KEY	Char	32	NODE_KEY for related hardware parent
LAST_UPDATE_TIME	Timestamp		Time stamp entry was last updated
HW_ID	Smallint		NODE_KEY identifier

**Table 26. NODE\_CAPACITY**

Column name	Column type	Column length	Description
NODE_KEY	Char	32	NODE GUID
PERIOD	Date		Month for this entry
START_TIME	Timestamp		First date that this entry is applicable for this Month
END_TIME	Timestamp		Last date that this entry is applicable for this Month
METRIC_TYPE	Char	10	Metric Type: MSU, SUBCAPMSTY
LAST_UPDATE_TIME	Timestamp		Time stamp entry was last updated
QUANTITY	Integer		Metric Value
MODEL_CAPACITY	Char	4	CPU model for capacity planning purpose

**Table 27. PRODUCT**

Column name	Column type	Column length	Description
SW_KEY	Char	32	Global Unique ID (GUID) for this entry. For SW_TYPE=VERSION this will be the same value as VERSION_GUID For SW_TYPE=FEATURE this will be the same value as FEATURE_GUID
SW_TYPE	Char	8	Entry type - VERSION or FEATURE
VENDOR_NAME	Char	50	Vendor name
PRODUCT_NAME	Char	5080	Product name, which is a normalized form of Version Name in order to group different versions of products under the same product name
VERSION	Integer		Version
VERSION_NAME	Char	5080	Product Version Title
FEATURE_NAME	Char	5080	Product Feature Title
PID	Char	16	Product Identifier
EID	Char	8	Entitlement Identifier for the Product Feature

**Table 27. PRODUCT****(continued)**

<b>Column name</b>	<b>Column type</b>	<b>Column length</b>	<b>Description</b>
SSPID	Char	8	Subscription & Support Product Identifier
SSEID	Char	8	Subscription & Support Entitlement Identifier for the Product Feature
PRICETYPE	Char	10	Price Type (not used in 7.2)
SUBCAPACITY	Char	20	IPLA Subcapacity type: Execution-based, Reference-based, z/OS-based, Not eligible, NULL
ICA	Char	1	Y or N: IBM Company Agreement license
IPLA	Char	1	Y or N: International Program License Agreement
VUE	Char	8	IPLA Value Unit Exhibit
VENDOR_GUID	Char	32	Globally Unique ID for VENDOR_NAME
PRODUCT_GUID	Char	32	Globally Unique ID for VENDOR_NAME + PRODUCT_NAME
VERSION_GUID	Char	32	Globally Unique ID for VENDOR_NAME + VERSION_NAME + VERSION
FEATURE_GUID	Char	32	Globally Unique ID for VENDOR_NAME + VERSION_NAME + VERSION + FEATURE_NAME
LAST_UPDATE_TIME	Timestamp		Time stamp entry was last updated
ALT_PRODUCT_NAME	Char	5080	Alternate product name
FOBSERVEDELETED	Timestamp		Date and time that the library was deleted from Inquisitor data.
BUNDLE_NAME	Char	50	Product suite
FSTYPE	Char	1	P=Product, S=Suite, X=Exclude, Null
FSUITE_ID	Smallint		ID of the Suite

**Table 28. PRODUCT\_INSTALL**

Column name	Column type	Column length	Description
SW_KEY	Char	32	Product GUID
SYSTEM_KEY	Char	32	System GUID
INSTALL_DATE	Date		Date the product was first observed to be installed on this System
UNINSTALL_DATE	Date		Date the product was first observed to be missing from this System
LAST_USED_DATE	Date		Date the product was last used on this System
LAST_UPDATE_TIME	Timestamp		Time stamp entry was last updated

**Table 29. PRODUCT\_NODE\_CAPACITY**

Column name	Column type	Column length	Description
SW_KEY	Char	32	Product GUID
NODE_KEY	Date		Node GUID
PERIOD	Timestamp		Month for this entry
START_TIME	Timestamp		First date that this entry is applicable for this Month
END_TIME	Timestamp		Last date that this entry is applicable for this Month
METRIC_TYPE	Integer		Metric Type: INSTALLED, JOB NAMES, MODULES, USERS, SUBCAPMSU
LAST_UPDATE_TIME	Timestamp		Time stamp entry was last updated
QUANTITY	Float		Metric Value

**Table 30. PRODUCT\_USE**

Column name	Column type	Column length	Description
PERIOD	Date		Month for this entry
SYSTEM_KEY	Char	32	System GUID
SW_KEY	Char	32	Product GUID
FLPARID	Integer		TLPAR.FLPARID for convenient linking with PRODUCT_USE_DETAIL
HW_NODE_KEY	Char	32	NODE GUID for Hardware NODE that this System was last running on in this month
USER_CNT	Integer		MAX distinct Userid count
JOBNAME_CNT	Integer		MAX distinct Job Name count
ACCOUNT_CNT	Integer		MAX distinct Account Code count
SCRT_MSU			Sub-capacity Reporting Tool MSU (millions of service units per hour)
EVENT_CNT	Double		SUM of Module usage
START_DATE	Date		Date within this Period that usage was for first recorded
END_DATE	Date		Date within this Period that usage was for last recorded
LAST_UPDATE_TIME	Timestamp		Time stamp entry was last updated
PRODUCTUSE	Double		Counter field for Product usage

**Table 31. PRODUCT\_USE\_DETAIL**

Column name	Column type	Column length	Description
PERIOD	Date		Month for this entry
FLPARID	Integer		System TLPAR.FLPARID for convenient linking with PRODUCT_USE
VERSION_GUID	Char	32	Product Version GUID

**Table 31. PRODUCT\_USE\_DETAIL**

(continued)

Column name	Column type	Column length	Description
FEATURE_GUID	Char	32	Product Feature GUID
USERNAME	Char	8	User ID
JOBNAME	Char	8	Job Name
ACCOUNTCODE	Char	20	First 20 chars of the Job Account Code
EVENT_CNT	Double		SUM of Module usage
START_DATE	Date		Date within this Period that usage was for first recorded
END_DATE	Date		Date within this Period that usage was for last recorded
PRODUCTUSE	Double		Counter field for Product usage

**Table 32. SYSTEM**

Column name	Column type	Column length	Description
SYSTEM_KEY	Char	32	Global Unique ID (GUID) for this entry
LAST_UPDATE_TIME	Timestamp		Time stamp entry was last updated
SID	Char	4	Product system ID. By default this is the SMFID. In cases where the same SMFID is used on different systems, the SID must be defined to a unique value for the customer enterprise in the Usage Monitor
SMFID	Char	4	z/OS® SMF ID
SYSPLEX	Char	8	z/OS® Sysplex name
IPADDR	Varchar	45	Host TCP/IP address
HOSTNAME	Varchar	256	Host TCP/IP name
FOBSERVEDELETED	Timestamp		Date and time that system was deleted from Inquisitor data
FOSVERSION	Char	8	Version of the z/OS

**Table 33. SYSTEM\_NODE**

Column name	Column type	Column length	Description
SYSTEM_KEY	Char	32	System GUID
NODE_KEY	Char	32	Node GUID
PERIOD	Date		Month this entry is for
START_TIME	Timestamp		Time it was first observed that this system is using this Node in this month period
END_TIME	Timestamp		Time it was last observed that this system is using this Node in this month period
LAST_UPDATE_TIME	Timestamp		Time stamp entry was last updated

**Table 34. TACCOUNT**

Column name	Column type	Column length	Description
FACCOUNTID	Integer		Account ID
FACCOUNTCODE	Char	20	Job Account Code, truncated to 20 characters

**Table 35. TALTERNATE**

Column name	Column type	Column length	Description
PRODUCT_NAME	Char	5080	Product name, which is a normalized form of Version Name in order to group different versions of products under the same product name
ALT_PRODUCT_NAME	Char	5080	Alternate product name
BUNDLE_NAME	Char	50	Product suite

**Table 36. TANNOTATE**

Column name	Column type	Column length	Description
FTYPE	Char	1	Annotation type: <ul style="list-style-type: none"> <li>• A – Asset</li> <li>• D- Discovery</li> <li>• B - Both</li> </ul>
PRODUCT_GUID	Char	32	Globally Unique ID for VENDOR_NAME + PRODUCT_NAME
FANNOTATION	Varchar	255	Text that is annotation

**Table 37. TCHANNEL\_PATH**

Column name	Column type	Column length	Description
SID	Char	4	Product system ID. By default this is the SMFID
CP_CHPID	Char	4	Channel path identifier
CP_TYPE	Char	5	Channel path type acronym
PERIOD	Date		Month for this entry
CP_DESC	Char	32	Channel path description

**Table 38. TCONTROL\_UNIT**

Column name	Column type	Column length	Description
SID	Char	4	Product system ID. By default this is the SMFID
PERIOD	Date		Month for this entry
CU_DEV1	Char	4	First device number
CU_DEV2	Char	4	Last device number
CU_DEVCT	Integer		Device count for CU record

**Table 38. TCONTROL\_UNIT**

(continued)

Column name	Column type	Column length	Description
CU_UNTNM	Char	8	Generic device unit name
CU_CHN1	Char	4	Channel path 1
CU_CHN2	Char	4	Channel path 2
CU_CHN3	Char	4	Channel path 3
CU_CHN4	Char	4	Channel path 4
CU_CHN5	Char	4	Channel path 5
CU_CHN6	Char	4	Channel path 6
CU_CHN7	Char	4	Channel path 7
CU_CHN8	Char	4	Channel path 8
CU_TYPE	Char	6	Control unit type
CU_MODEL	Char	3	Control unit model
CU_MFR	Char	3	Control unit manufacturer
CU_PLANT	Char	2	Control unit plant of manufacture
CU_SEQNUM	Char	12	Control unit sequence number

**Table 39. TCSECT**

Column name	Column type	Column length	Description
FMODID	Integer		Module ID
FCSECTNAME	Char	40	Name of CSECT
FCSECTSIZE	Char	8	CSECT size
FCOMPDATE	Char	8	Compile date of CSECT
FCOMPTIME	Char	6	Compile time of CSECT
FCOMPNAME	Char	50	Compiler name

**Table 39. TCSECT**

(continued)

Column name	Column type	Column length	Description
FCOMPVERSION	Char	8	Compiler version
FLANGENV	Char	2	LE language type
FARCHLEVEL	Char	3	Architecture level
FOPTIMIZE	Char	1	Optimize level
FDSTATEMENTS	Char	6	Number of statements the DATA DIVISION of a COBOL program
FPSTATEMENTS	Char	6	Number of statements the PROCEDURE DIVISION of a COBOL program

**Table 40. TISVEOS**

Column name	Column type	Column length	Description
FPOVID	Integer		Product ID
FEOSDATE	Timestamp		End of Service Date

**Table 41. TJOBDATA**

Column name	Column type	Column length	Description
FJOBNAME	Char	8	Job Name
FJOBID	Integer		Job ID
FJOBTYPE	Char	6	Job Type

**Table 42. TLIBRARY**

Column name	Column type	Column length	Description
FLIBID	Integer		Library ID
FLIBNAME	Char	128	Library name
FINVID	Integer		Inventory ID
FCREATIONDATE	Timestamp		Library creation date on Mainframe
FLIBDEVNUM	Char	4	DASD device number
FREFERENCEDATE	Timestamp		Date library last referenced
FLIBVOLSER	Char	8	Volser library resides on
FTRACKSALLOC	Char	10	Number of allocated tracks
FTRACKSUSED	Char	10	Number of used tracks
FORIGIN	Char	1	Blank - PDS, E - PDSE, V - VTOC, Q - PDS (subtask QSAM scan)
FCATALOG	Char	1	S - SMS managed, C - Cataloged, U - uncataloged, W - cataloged on wrong volume
FLINKLIST	Char	1	Is this a link listed library?
FLINKPACK	Char	1	Is this library in the Linkpack
FAPFAUTH	Char	1	Is this library APF authorized
FLASTUSAGE	Date		1st month of the most recent usage applied to any module in this library
FUSEFLAG	Smallint		Flag for library usage
FMODCNT	Integer		Number of modules in library
FOBSERVEFIRST	Timestamp		Date and time that library was first observed
FOBSERVELAST	Timestamp		Date and time that library was last observed
FOBSERVEDELETED	Timestamp		Date and time that library was deleted from Inquisitor data.
FCHECKSUM	Char	40	A checksum of module names and sizes in a given library used to determine whether a library has changed.

**Table 42. TLIBRARY**

(continued)

Column name	Column type	Column length	Description
FSTORAGEGROUP	Char	8	The storage group the library belongs to
FLIBRARYCLASS	Char	30	Name of the Library Class

**Table 43. TLIBSYS**

Column name	Column type	Column length	Description
FLIBID	Integer		Library ID
FLPARID	Integer		LPAR ID
FOBSERVEFIRST	Timestamp		Date and time that library was first observed
FOBSERVELAST	Timestamp		Date and time that library was last observed
FOBSERVEDELETED	Timestamp		Date and time that library was deleted from Inquisitor data
FAPFAUTH	Char	1	APFAUTH flag Y or N
FAPFLASTUPDATE	Timestamp		Date and time field was last updated
FLINKLIST	Char	1	LINLIST indicator. If Y, then it is the linklist. If N, then not in the linklist

**Table 44. TLOGIQ**

Column name	Column type	Column length	Description
FIQDATE	Timestamp		Inquisitor date
FIMPORTDATE	Timestamp		Inquisitor Import date
FSID	Char	4	Product system ID. By default this is the SMFID
FSYSPLEXID	Char	8	z/OS Sysplex name
FFULLREMATCH	Char	1	Y or N. Described in job HSISIQIM
FPRODUCTONLY	Char	1	Y or N. Described in job HSISIQIM

**Table 44. TLOGIQ**

(continued)

Column name	Column type	Column length	Description
FOSTYPE	Char	4	z/OS or z/OS UNIX System Services
FPLX	Char	1	PLX option (Y or N) as defined in Inquisitor scan
FVERSIONGKB	Char	15	The version of the GKB that the IQ is matched with
FSPNUM	Char	8	System Product number of the z/OS
FFMID	Char	8	FMID of the z/OS
FOSNUM	Char	8	Product ID of the z/OS
FOSVERSION	Char	8	Version of the z/OS
HW_TYPE	Char	4	System z hardware type
HW_MODEL	Char	4	System z hardware model
HW_SERIAL	Char	12	System z hardware serial
FFILTER	Varchar	256	List of filters in the Inquisitor file
FAPARLVL	Char	7	APAR number

**Table 45. TLOGUI**

Column name	Column type	Column length	Description
FUMONDATE	Timestamp		Usage Monitor date
FIMPORTDATE	Timestamp		Usage Import date
FSID	Char	4	Product system ID. By default this is the SMFID
FSYSPLEXID	Char	8	z/OS Sysplex name
HW_TYPE	Char	4	System z Hardware Type
HW_MODEL	Char	4	System z Hardware Model
HW_SERIAL	Char	12	System z Hardware Serial
FFILTER	Varchar	256	List of filters in the UMON file
FAPARLVL	Char	7	APAR number

**Table 46. TLPAR**

Column name	Column type	Column length	Description
FLPARID	Integer		LPAR ID
FLPARNAME	Char	20	Name of the LPAR
FUSEFLAG	Smallint		Indicates if usage has been attributed to this LPAR
FEDITFLAG	Smallint		Has this LPAR record been updated manually
FMANF	Char	10	Machine manufacturer
FMACHINE	Char	12	CPU Model
FSERIALNO	Char	12	CPU Serial number
FSYSPLEXID	Char	8	Sysplex name if in a Sysplex
FMIPS	Integer		Number of MIPS for LPAR
FHW_NAME	Char	10	Configured hardware name
FIPADDR	Varchar	45	Host TCP/IP address
FHOSTNAME	Varchar	256	Host TCP/IP name
FOBSERVEDELETED	Timestamp		Date and time that LPAR was deleted from Inquisitor data
FMSU	Integer		MSU value for the LPAR
FHWMODEL	Char	12	Hardware Model
FSWCAP	Char	12	Software capacity model

**Table 47. TMACHINE\_RESOURCE**

Column name	Column type	Column length	Description
HW_NODE_KEY	Char	32	NODE GUID for Hardware NODE that this System was last running on in this month
LPAR_NAME	Char	10	Logical partition name
PERIOD	Date		Month for this entry
LPAR_NUMBER	Integer		Logical partition number

**Table 47. TMACHINE\_RESOURCE**

(continued)

Column name	Column type	Column length	Description
LPC_NAME	Char	10	LPC name
OSTYPE	Char	8	OS name
ENGINE_CNT1	Char	4	CPU available count
ENGINE_CNT2	Char	4	CPU online count
ENGINE_CNT3	Char	4	CPU dedicated count
ENGINE_CNT4	Char	4	zAAP available count
ENGINE_CNT5	Char	4	zAAP online count
ENGINE_CNT6	Char	4	zAAP dedicated count
ENGINE_CNT7	Char	4	IFL available count
ENGINE_CNT8	Char	4	IFL online count
ENGINE_CNT9	Char	4	IFL dedicated count
ENGINE_CNT10	Char	4	ICF available count
ENGINE_CNT11	Char	4	ICF online count
ENGINE_CNT12	Char	4	ICF dedicated count
ENGINE_CNT13	Char	4	zIIP available count
ENGINE_CNT14	Char	4	zIIP online count
ENGINE_CNT15	Char	4	zIIP dedicated count
ENGINE_CNT16	Char	4	Other available count
ENGINE_CNT17	Char	4	Other online count
ENGINE_CNT18	Char	4	Other dedicated count

**Table 48. TMODULE**

Column name	Column type	Column length	Description
FMODID	Integer		Module ID
FMODNAME	Char	40	Module name

Table 48. TMODULE

(continued)

Column name	Column type	Column length	Description
FLIBID	Integer		Library ID
FPOVLIBID	Integer		Product Library ID
FMODFLAG	Smallint		Module indication flag as to which product version it belongs to and whether it has been superseded.
FFMID	Char	12	FMID
FMODSIZE	Char	8	Module size
FUSEFLAG	Smallint		Flag for module usage
FMODTYPE	Smallint		Type of module
FOBSERVEFIRST	Timestamp		Date and time that module was first observed
FOBSERVELAST	Timestamp		Date and time that module was last observed
FOBSERVEDELETED	Timestamp		Date and time that module was deleted from Inquisitor data
LINKEDITDATE	Date		Link edit date of module
FCOMPNAME	Char	50	Name of the Compiler, for example, Enterprise COBOL
FCOMPVERSION	Char	50	Version of the Compiler
FCOMPDATE	Date		Compiled date of module
FAMODE	Char	3	Specifies the addressing mode in which the program is designed to receive control.
FRMODE	Char	3	Indicates where the program can reside in virtual storage.
FREUSE	Char	4	The REUS option allows you to specify how a program can be reused.
FFMIDIQ	Char	12	FMID found by Inquisitor for module
FPTF	Char	8	Last PTF number for module
FPUTLEVEL	Char	8	PUTLEVEL that module was in
FRSU	Char	8	Last RSU level that module was in

**Table 48. TMODULE**

(continued)

Column name	Column type	Column length	Description
FALIASNAME	Char	40	Alias name of module

**Table 49. TPARAM**

Column name	Column type	Column length	Description
FKEY	Char	64	Parameter Key
FVALUE	Char	254	Parameter Value

**Table 50. TPERIODS**

Column name	Column type	Column length	Description
FPERIOD	Date		Calendar month for usage
FINVID	Integer		Inventory ID
FSUMMARISED	Smallint		Summary status

**Table 51. TPOVINV**

Column name	Column type	Column length	Description
FPOVINVID	Integer		Unique ID
FPOVID	Integer		Product ID
FINVID	Integer		Inventory ID
FPOVGID	Integer		Global Knowledge Base Version ID
FOBSERVEFIRST	Timestamp		First time observation was made
FOBSERVELAST	Timestamp		Last time observation was made
FOBSERVEDELETED	Timestamp		First time observation was not found in this library

**Table 51. TPOVINV**

(continued)

Column name	Column type	Column length	Description
FPRODUCTID	Integer		Product ID
FVENDORID	Integer		Vendor ID
FPRODINVID	Integer		Product and Inventory ID
FPATCHLIST	Varchar	254	List of current patches applied to z/OS® UNIX™ product.

**Table 52. TPOVLIB**

Column name	Column type	Column length	Description
FPOVLIBID	Integer		Unique ID
FPOVINVID	Integer		Product inventory ID
FLIBID	Integer		Library ID
FPOVLIBPID	Integer		Previous Product Version ID
FMATCHCODE	Char	3	Matching code
FMATCHID	Integer		Link to Inquisitor Decision table
FPRODUCTPCT	Integer		Product percentage used during match
FVERSIONPCT	Integer		Version percentage used during match
FOBSERVEFIRST	Timestamp		First time observation was made
FOBSERVELAST	Timestamp		Last time observation was made
FOBSERVEDELETED	Timestamp		First time observation was not found in this library
FMODCNT	Integer		Number of load modules in library for product

**Table 53. TPRODUCT**

Column name	Column type	Column length	Description
FPRODUCTID	Integer		Product ID

**Table 53. TPRODUCT**

(continued)

Column name	Column type	Column length	Description
FPRODUCTNAME	Char	5080	Product Name (could be alias name)
FGLOBALNAME	Char	5080	Product Name (always Global Name if Alias is used)
FOPTIONNAME	Char	3080	Option Name
FVENDORID	Integer		Vendor ID
FPRODSTATUS	Smallint		Billable Status
FCATEGORY	Char	30	Product Category
FDESCRIPTION	Varchar	254	Product Description
FOBSERVEDELETED	Timestamp		Date and time that the library was deleted from Inquisitor data.
FTYPE	Char	1	P=Product, M=Maybe, N=None, U=Unknown

**Table 54. TPRODUCT\_REGISTRATION**

Column name	Column type	Column length	Description
SID	Char	4	Product system ID. By default this is the SMFID
PID	Char	16	Product Identifier
PRODUCT_OWNER	Char	16	Product owner or vendor
PRODUCT_NAME	Char	50	Product name
PRODUCT_FEATURE	Char	16	Product feature or option name
PRODUCT_VERSION	Char	6	Product version
PRODUCT_FLAGS	Char	8	Register state entry flags
PERIOD	Date		Month for this entry

**Table 55. TREGISTERED\_PRODUCT\_USAGE**

Column name	Column type	Column length	Description
SID	Char	4	Product system ID. By default this is the SMFID
PRODUCT_OWNER	Char	16	Product owner or vendor
PRODUCT_NAME	Char	50	Product name
PRODUCT_VERSION	Char	8	Product version
PRODUCT_QUALIFIER	Char	8	Product qualifier
PERIOD	Date		Month for this entry
PID	Char	16	Product Identifier
PRODUCT_FLAGS	Char	8	Register usage entry flags
SMFRECORDS	Integer		SMF record count
TCBTIME	Integer		Product TCB time
SRBTIME	Integer		Product SRB time

**Table 56. TUSEMTD**

Column name	Column type	Column length	Description
FMTDID	Float		Unique ID
FLPARID	Integer		LPAR ID
FMODID	Integer		Module ID
FJOBID	Integer		Job ID
FUSERID	Integer		User ID
FPOVLIBID	Integer		Product Library ID
FEVENTCNT	Float		Total calls to module for this month
FPERIOD	Date		Calendar month that usage occurred
FFIRSTDATE	Date		First day of usage in the month
FLASTDATE	Date		Last day of usage in the month
FPROVIDER	Char	4	Provider Service

**Table 56. TUSEMTD**

(continued)

Column name	Column type	Column length	Description
FPOVINVID	Integer		Unique ID
FPRODINVID	Integer		Product and Inventory ID
FACCOUNTID	Integer		Account ID
FJESID	Char	8	Last JES job ID updated for the month
FTCBCNT	Float		TCB count
FTCBTIME	Float		TCB time
FHWID	Smallint		NODE_KEY identifier

**Table 57. TUSEPOV**

Column name	Column type	Column length	Description
FUSEPOVINVID	Float		Unique ID
FLARPID	Integer		LPAR ID
FPOVINVID	Integer		POVINVID
FJOBcnt	Integer		Number of distinct Jobs for a product
FUSERCNT	Integer		Number of distinct Users for a product
FEVENTCNT1	Float		Sum of calls to this product current month
FEVENTCNT3	Float		Sum of calls to this product previous 3 month
FEVENTCNT6	Float		Sum of calls to this product previous 4-6 month
FEVENTCNT9	Float		Sum of calls to this product previous 7-9 month
FEVENTCNT12	Float		Sum of calls to this product previous 10-12 month
FPERIOD	Date		Calendar month in which usage occurred
FFIRSTUSED	Date		The earliest usage date in month
FLASTUSED	Date		The most recent usage date in month
FPRODINVID	Integer		Product Inventory ID
FSEQNO	Smallint		Internal use only

**Table 57. TUSEPOV**

(continued)

Column name	Column type	Column length	Description
FACCCNT	Integer		Number of distinct account codes
FTCBCNT	Float		TCB count
FTCBTIME	Float		TCB time
FHWID	Smallint		NODE_KEY identifier

**Table 58. TUSEPOVLIB**

Column name	Column type	Column length	Description
FUSEPOVLIBID	Float		Unique ID
FLARPID	Integer		LPAR ID
FPOVLIBID	Integer		POVLIB ID
FJOBCNT	Integer		Number of distinct Jobs for a product
FUSERCNT	Integer		Number of distinct Users for a product
FEVENTCNT1	Float		Sum of calls to this product current month
FEVENTCNT3	Float		Sum of calls to this product previous 3 month
FEVENTCNT6	Float		Sum of calls to this product previous 4-6 month
FEVENTCNT9	Float		Sum of calls to this product previous 7-9 month
FEVENTCNT12	Float		Sum of calls to this product previous 10-12 month
FPERIOD	Date		Calendar month in which usage occurred
FFIRSTUSED	Date		The earliest usage date in month
FLASTUSED	Date		The most recent usage date in month
FSEQNO	Smallint		Internal use only
FACCCNT	Integer		Number of distinct account codes
FTCBCNT	Float		TCB count
FTCBTIME	Float		TCB time
FHWID	Smallint		NODE_KEY identifier

**Table 59. TUSEPRS**

Column name	Column type	Column length	Description
FUSEPRSID	Integer		Unique ID for TUSEPRS table
FREGVEND	Char	16	Product Registration Vendor name
FREGPROD	Char	16	Product Registration Product name
FREGFEAT	Char	16	Product Registration Feature name
FREGVRN	Char	6	Product Registration Version
FREGPID	Char	8	Product Registration Product identifier
FREGFLAGS	Char	8	Product Registration flags
FLPARID	Integer		LPAR ID
FPERIOD	Date		Calendar month when usage occurred
FFIRSTDATE	Date		The earliest usage date in month
FLASTDATE	Date		The most recent usage date in month

**Table 60. TUSERDATA**

Column name	Column type	Column length	Description
FUSERID	Integer		User ID
FUSERNAME	Char	10	User Name
FORGNAME	Char	8	Owning Organization
FREALNAME	Char	20	Real person's name

**Table 61. TVENDOR**

Column name	Column type	Column length	Description
FVENDORID	Integer		Vendor ID
FVENDORNAME	Char	50	Vendor Name (could be alias name)

**Table 61. TVENDOR**

(continued)

Column name	Column type	Column length	Description
FGLOBALNAME	Char	3080	Reserved
FVENDORGUID	Char	32	Vendor globally unique ID
FOBSERVEDELETED	Timestamp		Date and time that the library was deleted from Inquisitor data.

**Table 62. TVERSION**

Column name	Column type	Column length	Description
FPOVID	Integer		Version ID
FVERSIONNAME	Char	44	Version name
FPPNUMNAME	Char	16	PPNUM
FPRODUCTID	Integer		Product Option ID
FMINUSAGE	Float		Minimum usage threshold
FVERSIONGUID	Char	32	Product version globally unique identifier. PRODUCT.SW_KEY for SW_TYPE = VERSION
FFEATUREGUID	Char	32	Product feature globally unique identifier. PRODUCT.SW_KEY for SW_TYPE = FEATURE
FOBSERVEDELETED	Timestamp		Date and time that the library was deleted from Inquisitor data.
FFMID	Char	8	FMID of the z/OS
FSUITE_ID	Smallint		ID of the Suite
FPTF	Char	8	The PTF level of the product
FPUTLEVEL	Char	8	The PUTLEVEL of the product
FRSU	Char	8	The maintenance level of the product

**Table 63. ACTIVCON (V8.2)**

Column name	Column type	Column length	Description
ACTIVCON_ID	Integer		Active Container ID
CONTAINER_ID	Char	6	ID of the Container
CONTAINER_NAME	Char	50	Name of the Container
SOLUTION_ID	Char	64	The solution ID supplied by IBM
MACHINE_ID	Char	6	Name of the Machine
SERIAL	Char	12	System z Hardware Serial
PERIOD	Date		Reporting Period
PEAK_4HOUR	Integer		Peak 4 Hour Consumption
TOTAL_MSU	Integer		Total MSU Consumption

**Table 64. ACTIVPRD (V8.2)**

Column name	Column type	Column length	Description
CONTAINER_ID	Char	6	ID of the Container
PID	Char	16	Product Identifier
SOLUTION_ID	Char	64	The solution ID supplied by IBM
PERIOD	Date		Reporting Period
PRODUCT	Char	80	Name of the Product
PRDTYPE	Char	8	MLC or IPLA
MACHINE_ID	Char	6	Name of the Machine
SERIAL	Char	12	System z Hardware Serial

**Table 65. CONTCPU (V8.2)**

Column name	Column type	Column length	Description
MACHINE_ID	Char	6	Name of the Machine
SERIAL	Char	12	System z Hardware Serial
MODEL	Char	10	Model of the Harware - eg 2965-605
PERIOD	Date		Reporting Period
MSU	Integer		Total MSU for the machine

**Table 66. CONTLPAR (V8.2)**

Column name	Column type	Column length	Description
LPAR_ID	Char	20	Name of the LPAR
TOTAL_MINUTES	Integer		Total minutes LPAR could have been online
TOTAL_MINUTES_COLLECTED	Integer		Total minutes for LPAR collected
MISSING_MINUTES	Integer		Missing minutes between possible online and actual collected.
TOTAL_MSU_CONSUM	Integer		Total MSU Consumed
CONTAINER_ID	Char	6	ID of the Container
PERIOD	Date		Reporting Period
PEAK_HOUR_CONSUM	Integer		Peak Hour MSU consumption
MACHINE_ID	Char	6	Name of the Machine
SERIAL	Char	12	System z Hardware Serial

**Table 67. CONTNER (V8.2)**

Column name	Column type	Column length	Description
CONTAINER_ID	Char	6	ID of the Container
CONTAINER_NAME	Char	50	Name of the Container

**Table 67. CONTNER (V8.2)**

(continued)

Column name	Column type	Column length	Description
SOLUTION_ID	Char	64	The solution ID supplied by IBM
PERIOD	Date		Reporting Period
TOTAL_MSU	Integer		Total MSU consumed by the Container
MACHINE_ID	Char	6	Name of the Machine
SERIAL	Char	12	System z Hardware Serial

**Table 68. EXCLUDE\_SUITES (V8.2)**

Column name	Column type	Column length	Description
FLPARID	Integer		LPAR ID
FSYSPLEXID	Char	8	z/OS Sysplex name
PRODUCT_NAME	Char	80	Name of the Product
VERSION	Char	16	Version of the Product
PID	Char	16	PID of the Suite
SUITE_ID	Smallint		ID of the Suite

**Table 69. PRODUCT\_SUITES (V8.2)**

Column name	Column type	Column length	Description
FLPARID	Integer		LPAR ID
FSYSPLEXID	Char	8	z/OS Sysplex name
SUITE_ID	Smallint		ID of the Suite
SUITE_NAME	Char	80	Name of the Suite
SUITE_VERSION	Char	16	Version of the Suite
PID	Char	16	PID of the Suite

**Table 69. PRODUCT\_SUITES (V8.2)**

(continued)

Column name	Column type	Column length	Description
SW_KEY	Char	32	Global Unique ID (GUID) for this entry. For SW_TYPE=VERSION this will be the same value as VERSION_GUID. For SW_TYPE=FEATURE this will be the same value as FEATURE_GUID.
VENDOR_NAME	Char	50	Vendor name of the Suite
FOBSERVEDELETED	Timestamp		Date and time that suite was deleted from system

**Table 70. PRODUCT\_VUE (V8.2)**

Column name	Column type	Column length	Description
PRODUCT_NAME	Char	80	Product Name
FEATURE_NAME	Char	80	Feature Name
PID	Char	16	Product PID
VUPID	Char	16	VUE PID
VUEID	Char	8	VUE EID
VUSSPID	Char	8	VUE S&S PID
VUSSEID	Char	8	VUE S&S EID
VUICA	Char	1	VUE ICA
VUIPLA	Char	1	VUE IPLA

**Table 71. TLOGAGGR(V8.3)**

Column name	Column type	Column length	Description
FRUNDATE	Timestamp		Date and time Aggregator was run
FCOUNTUSAGEFULL	Char	1	Input value of parameter COUNTUSAGEFULL. Default value is N
FAPARLVEL	Char	7	APAR number
GKBVERSION	Char	6	Version of the GKB

**Table 72. TLOGLDEL(V8.3)**

Column name	Column type	Column length	Description
FRUNDATE	Timestamp		Date and time LPAR deletion was run
FSID_PARM	Char	8	Input value of parameter SID
FAPARLVEL	Char	7	APAR number

**Table 73. TLOGPDEL(V8.3)**

Column name	Column type	Column length	Description
FRUNDATE	Timestamp		Date and time Physical deletion was run
FFIRSTDATE	Char	6	Input value of parameter FIRSTDATE
FLASTDATE	Char	6	Input value of parameter LASTDATE
FAPARLVEL	Char	7	APAR number
FTLIBRARY_DEL	Integer		Number of records deleted from TLIBRARY table
FTLIBSYS_DEL	Integer		Number of records deleted from TLIBSYS table
FTMODULE_DEL	Integer		Number of records deleted from TMODULE table
FTPOVLIB_DEL	Integer		Number of records deleted from TPOVLIB table
FTCSECT_DEL	Integer		Number of records deleted from TCSECT table
FTVENDOR_DEL	Integer		Number of records deleted from TVENDOR table
FTVERSION_DEL	Integer		Number of records deleted from TVERSION table
FTPRODUCT_DEL	Integer		Number of records deleted from TPRODUCT table

**Table 74. TLOGUDEL(V8.3)**

Column name	Column type	Column length	Description
FRUNDATE	Timestamp		Date and time Usage deletion was run
FSID_PARM	Char	8	Input value of parameter SID (LPAR name or 'ALLSIDS')
FKEEPDETAIL	Smallint		Input value of parameter KEEPDETAIL. Default value is 2
FKEEPAGGR	Smallint		Input value of parameter KEEPAGGR. Default value is 12
FFIRSTDATE	Char	6	Input value of parameter FIRSTDATE
FLASTDATE	Char	6	Input value of parameter LASTDATE

**Table 74. TLOGUDEL(V8.3) (continued)**

Column name	Column type	Column length	Description
FAPARLVEL	Char	7	APAR number
FTUSEMTD_DEL	Integer		Number of records deleted from TUSEMTD table

## Post-installation jobs

After installation, you can create a custom version of any job in the JCLLIB library or any parameter in the PARMLIB library, by copying and editing the relevant job in the HSISCUST member in the hsi.SHSISAMP data set.

### Jobs generated in JCLLIB for a Db2® environment

The custom JCLLIB members that you create with post-installation customization in a Db2® environment are used to submit jobs to implement the product.

#### Post installation jobs

The following table lists the post-installation jobs generated in the JCLLIB library when the DBTYPE=DB.

**Table 75. Post-installation jobs generated for a Db2® database**

Job	Description
HSISDB01	Job to define Db2® storage groups.
HSISDB02	Job to define the GKB database.
HSISDB03	Job to define the repository database.
HSISGKBL	Job to populate the GKB, GKB for z/OS® UNIX®, and Inquisitor filters.
HSISGRNT	Job to grant administrator access to the repository and GKB databases.
HSISGRTB	Job to grant SELECT access to the repository and GKB tables.
HSISANS1	Job to set up RACF® security profiles in the Analyzer utility.
HSISANS2	Job to set up new SSL certificates in the Analyzer utility.
HSISANS3	Job to use existing SSL certificates in the Analyzer utility.

## Operations jobs

The following table lists the operations jobs generated in the JCLLIB library when the DBTYPE is set to DB2®.

**Table 76. Operations jobs generated for a Db2® database**

Job	Description
HSISGKBL	Job to populate the GKB, GKB for z/OS® UNIX®, and Inquisitor filters. To be run when monthly updates are provided.
HSISINQZ	Job to run the Inquisitor.
HSISINQU	Job to run the Inquisitor for z/OS® UNIX®.
HSISIQIM	Job to run the Inquisitor Import for z/OS® and z/OS® UNIX®.
HSIJMON	Started task - Usage Monitor.
HSISUMON	Job to run the Usage Monitor.
HSISUIMP	Job to run the Usage Import.
HSIJAUTO	Started task - Automation Server.
HSIASALC	Job to allocate the Automation Server control file.
HSIASSCT	Job to run the Automation Server Scout utility.

## Reporting jobs

The following table lists the reporting jobs generated in the JCLLIB library when the DBTYPE is set to DB2®.

**Table 77. Reporting jobs generated for a Db2® database**

Job	Description
HSIJANLO	Started task - Analyzer online mode.
HSISANLO	Job to run Analyzer reporting in online mode.

**Table 77. Reporting jobs generated for a Db2® database (continued)**

Job	Description
HSISANLB	Job to run Analyzer reporting in batch mode.

**Utility jobs**

The following table lists the Utility jobs generated in the JCLLIB library when the DBTYPE is set to DB2®.

**Table 78. Utility jobs generated for a Db2® database**

Job	Description
HSISZCAT	Job to concatenate and aggregate Usage Monitor data sets.
HSISPTAG	Job to run the Product Tagging utility.
HSISUDEL	Job to run the usage deletion.
HSISLDEL	Job to run the system deletion.
HSISPDEL	Job to run the physical deletion.
HSISLLST	Job to create an HLQ listing for the Usage Monitor.
HSISSCRT	Job to read SCRT CSV files and populate the repository.
HSISKBT	Job to run the XML utility. The XML output is for IBM Control Desk (ICD).
HSISIBM	Job to filter out non-IBM® programs from the Inquisitor utility and usage data.
HSISPLTX	Job to create a PLT entry for CICS®.
HSISENAX	Job to enable CICS® GLUE program.
HSISUT01	Sample job to backup the repository database.

**Table 78. Utility jobs generated for a Db2® database (continued)**

Job	Description
HSISUT02	Sample job to restore the repository database.
HSISUT03	Sample job to reorganize the repository database.
HSISUT04	Sample job to run the RUNSTATS utility on the repository database.
HSISIPVD	Diagnostic. Job to verify database changes since the product was released.
HSISTPRM	Diagnostic. Job to update the repository TPARAM table.
HSISCSI	Diagnostic. Job to gather SMP/E diagnostics data.
HSISSTAG	Job to get UMON/ZCAT data into a staging table.

### Jobs for porting data between repositories

The following table lists the jobs generated in the JCLLIB library for porting data between repositories when the DBTYPE=DB2®.

**Table 79. Jobs generated for porting data between repositories for a Db2® database**

Job	Description
HSISUN83	Job to unload the repository database.
HSISLO83	Job to load the repository database.

### Migration jobs

The following table lists the migration jobs generated in the JCLLIB library when the DBTYPE is set to Db2®.

**Table 80. Migration jobs generated for a Db2® database**

Job	Description
HSISVS21	Job to verify database objects/counts.
HSISVS22	Job to update Repository TPARAM table, create new V8.3 database objects.

**Table 80. Migration jobs generated for a Db2® database (continued)**

Job	Description
HSISVS25	Job to verify newly created V8.3 database objects.

### Globalization jobs

The following table lists the globalization jobs generated in the JCLLIB library when the DBTYPE is set to Db2®.

**Table 81. Globalization jobs generated for a Db2® database**

Job	Description
HSISMCOMP	Job to compile Japanese messages for MMS.

### Jobs generated in JCLLIB for a remote environment

The custom JCLLIB members that you create with post-installation customization in a remote environment are used to submit jobs to implement the product.

### Operations jobs

The following table lists the operations jobs generated in the JCLLIB library when the DBTYPE=REMOTE.

**Table 82. Operations jobs generated for a remote environment**

Job	Description
HSISINQZ	Job to run the Inquisitor
HSISINQU	Job to run the Inquisitor for z/OS UNIX
HSIJMON	Started task - Usage Monitor
HSISUMON	Job to run the Usage Monitor
HSIJAUTO	Started task - Automation Server
HSIASALC	Job to allocate the Automation Server control file
HSIASSCT	Job to run the Automation Server Scout utility

## Utility jobs

The following table lists the Utility jobs generated in the JCLLIB library when the DBTYPE=REMOTE.

**Table 83. Utility jobs generated for a remote environment**

Job	Description
HSISZCAT	Job to concatenate and aggregate Usage Monitor data sets
HSISPTAG	Job to run the Product Tagging utility
HSISIBM	Optional. Job to filter out non-IBM programs from the Inquisitor and usage data
HSISPLTX	Optional. Job to create a PLT entry for CICS
HSISENAX	Optional. Job to enable CICS GLUE program
HSISCSI	Diagnostic. Job to gather SMP/E diagnostics data

## Jobs generated in JCLLIB for an SQLite environment

The custom JCLLIB members that you create with post-installation customization in an SQLite environment are used to submit jobs to implement the product.

### Post installation jobs

The following table lists the post-installation jobs generated in the JCLLIB library when the DBTYPE=SQLITE.

**Table 84. Post-installation jobs generated for a SQLite database**

Job	Description
HSISDB01	Job to create SQLite zFS file system
HSISDB02	Job to define the GKB database
HSISDB03	Job to define the repository database
HSISGKBL	Job to populate the GKB, GKB for z/OS® UNIX®, and Inquisitor filters
HSISGRNT	Job to grant access to z/OS® OMVS groups

**Table 84. Post-installation jobs generated for a SQLite database (continued)**

Job	Description
HSISANS1	Job to set up RACF® security profiles in Analyzer
HSISANS2	Job to set up new SSL certificates in Analyzer
HSISANS3	Job to to use existing SSL certificates in Analyzer

### Operations jobs

The following table lists the operations jobs generated in the JCLLIB library when the DBTYPE is set to SQLITE.

**Table 85. Operations jobs generated for a SQLite database**

Job	Description
HSISGKBL	Job to populate the Global Knowledge Base, Global Knowledge Base for z/OS® UNIX®, and Inquisitor filters. To be run when monthly updates are provided.
HSISINQZ	Job to run the Inquisitor
HSISINQU	Job to run the Inquisitor for z/OS® UNIX®
HSISIQIM	Job to run the Inquisitor Import for z/OS® and z/OS® UNIX®
HSIJMON	Started task - Usage Monitor
HSISUMON	Job to run the Usage Monitor
HSISUIMP	Job to run the Usage Import
HSIJAUTO	Started task - Automation Server
HSIASALC	Job to allocate the Automation Server control file
HSIASSCT	Job to run the Automation Server Scout utility

## Reporting jobs

The following table lists the reporting jobs generated in the JCLLIB library when the DBTYPE is set to SQLITE.

**Table 86. Reporting jobs generated for a SQLite database**

Job	Description
HSIJANLO	Started task - Analyzer online mode
HSISANLO	Job to run Analyzer reporting in online mode
HSISANLB	Job to run Analyzer reporting in batch mode

## Utility jobs

The following table lists the Utility jobs generated in the JCLLIB library when the DBTYPE is set to SQLITE.

**Table 87. Utility jobs generated for a SQLite database**

Job	Description
HSISZCAT	Job to concatenate and aggregate Usage Monitor data sets
HSISPTAG	Job to run the Product Tagging utility
HSISUDEL	Job to run the Usage Deletion
HSISLDEL	Job to run the System Deletion
HSISPDEL	Job to run the physical deletion
HSISSCRT	Job to read SCRT CSV files and populate the Repository
HSISIBM	Job to filter out non-IBM® programs from the Inquisitor and usage data
HSISPLTX	Job to create a PLT entry for CICS®
HSISENAX	Job to enable CICS® GLUE program

**Table 87. Utility jobs generated for a SQLite database (continued)**

Job	Description
HSISUT01	Sample job to backup SQLite zFS file system
HSISUT02	Sample job to restore SQLite zFS file system
HSISIVPD	Diagnostic. Job to verify database changes since the product was released
HSISTPRM	Diagnostic. Job to update the Repository TPARAM table
HSISSQLT	Diagnostic. Job to display SQLite database files
HSISMNT	Diagnostic. Job to mount SQLite zFS file system and optionally delete the zFS file system
HSISMNTU	Diagnostic. Job to unmount SQLite zFS file system after an IPL

### Jobs for porting data between repositories

The following table lists the jobs generated in the JCLLIB library for porting data between repositories when the DBTYPE=SQLITE.

**Table 88. Jobs generated for porting data between repositories for a SQLite database**

Job	Description
HSISUN83	Job to unload the repository database
HSISLO83	Job to load the repository database

### Migration jobs

The following table lists the migration jobs generated in the JCLLIB library when the DBTYPE is set to SQLITE.

**Table 89. Migration jobs generated for a SQLite database**

Job	Description
HSISVS21	Job to verify database objects/counts.
HSISVS22	Job to update Repository TPARAM table, create new V8.3 db objects.

**Table 89. Migration jobs generated for a SQLite database (continued)**

Job	Description
HSISVS23	Job to migrate tables for altered columns.
HSISVS24	Job to drop obsolete tables in Repository/LKB/LKU.
HSISVS25	Job to verify newly created V8.3 database objects.

### Globalization jobs

The following table lists the globalization jobs generated in the JCLLIB library when the DBTYPE is set to SQLITE.

**Table 90. Globalization jobs generated for a SQLite database**

Job	Description
HSISMCMP	Job to compile Japanese messages for MMS

## Database performance and tuning

You can perform various configurations to tune your database to provide the best performance for your IBM Z Software Asset Management environment.

### Db2® performance and tuning

Various configuration options are available to assist you in optimizing performance for your environment.

#### Initial space allocation

This section is useful for the database administrator who must determine space requirements for IBM Z Software Asset Management . Listed in [Table 91: Initial space allocation for the product on page 230](#) are guidelines for the initial spaces allocation based on the number of LPARs. The value for the SIZE parameter is specified in HSISCUST.

**Table 91. Initial space allocation for the product**

SIZE=	Initial space allocation	Number of LPARs
1	1600 cylinders	1-10
2	3750 cylinders	11-20
3	12600 cylinders	>20

In version 8.2, all table spaces and indexes are defined with 'COMPRESS Y'. For estimated space requirements of the 3 largest table spaces, refer to PARMLIB member HSISQ17.

### **Choosing a Db2® subsystem for this product**

The Db2® resources required for this product do not need to be defined in a production Db2® subsystem in order to minimize competition for mainframe resources in the Db2® production environments. To avoid competing for mainframe resources, run the jobs for the Inquisitor Import and Usage Import during off-peak periods. In addition, run the utility Usage Deletion during off-peak periods.

### **Buffer pools**

By allocating the appropriate buffer pool to the respective table spaces and indexes, as defined in HSISCUST, you can manage your system resources accordingly. For Db2® performance, first investigate the buffer pools. Check with your site specialist on the types and size of buffer pools that are defined for this product.

For sites using Db2 data sharing, group Bufferpools must be defined with the same names.

### **Space allocation and utilization**

In terms of space utilization, -1 has been set for all SECQTY to enforce Sliding Secondary Extents. This enables Db2® to manage secondary extents efficiently, and minimizes extension failures. You need to extrapolate the PRIQTY for the table spaces and indexes for the large tables according to your requirements. Definitions for these Db2® objects are listed in the respective jobs in JCLLIB.

Repository tables with the biggest impact on performance due to size are TMODULE, TUSEMTD, and PRODUCT\_USE\_DETAIL. Data for the TMODULE table is populated during Inquisitor Import process. TUSEMTD, and PRODUCT\_USE\_DETAIL tables are populated during Usage Import. For example, you might have more than 300 million usage records in the TUSEMTD table, and more than 20 million modules identified in the TMODULE table. To minimize space utilization and improve SQL query performance, you must prune your usage and obsolete records by running the Usage Deletion job HSISUDEL and Physical Deletion job HSISPDEL.

### **Declared Global Temporary tables**

Declared Global Temporary tables are used during the Asset Aggregator process. The Work file table spaces must be large enough to handle this process. When the Aggregator job step is run, indexes on declared global temporary tables are created. By default, the bufferpool used by the index is dependent on the bufferpool defined for the Work file database. Parameter IXBUFFERPOOL in PARMLIB member HSISAGP1 can be used to substitute the default value.

### **Work file database**

When you run some of the SQL queries, they can produce a large amount of output. In order to avoid any excessive output, increase the number and size of the table spaces in the work file database.

### **Reorganization and RUNSTATS**

It is important to run reorganization of the Repository table spaces periodically, especially after Inquisitor Imports, Usage Imports, and Usage Deletion. After reorganization of the Repository table spaces, it is also a good idea to run RUNSTATS for these table spaces.

## SQLite performance and tuning

### General zFS performance queries

zFS performance is dependent on many factors. To help you to optimize performance, zFS provides performance information to help determine bottlenecks. You can enter the following system commands to get information about the current operation of zFS:

- F ZFS, QUERY, SETTINGS
- F ZFS, QUERY, ALL

To query and reset performance counters, enter the following z/OS® UNIX® System Services command:

```
zfsadm
```

### Resource Management Facility (RMF™) support for zFS

RMF™ support is available for zFS. When you are considering zFS performance, investigate the zFS components that are involved in I/O processing to or from a zFS file system. In a shared file system environment it is better for performance if you can mount a file system as read-only rather than as read-write. If a file system is mounted as read-write, but is accessed primarily from a single system, such as SYS1, it can improve performance if that file system is z/OS® UNIX® owned on system SYS1.

You can also optimize zFS performance by tailoring the size of its caches to reduce I/O rates and path length. It is also important to monitor DASD performance to ensure that no disc volumes or channels are required to perform beyond the intended capacity.

### Monitoring and tuning cache size to improve zFS performance

You can improve the performance of zFS by controlling the size of the caches that hold file system and log data. Monitor the following caches so that you can control them effectively to reduce I/O rates:

- The user file cache is used for all user files and performs I/O for all user files greater than 7 KB.
- The metadata cache performs I/O for all user files that are smaller than 7 KB.
- The log file cache stores file record transactions that describe changes to the file system.

## Database resources used by IBM Z Software Asset Management

The following tables list the database resources. The PARMLIB members provide definitions for these database resources.

### &GKBZSCHM\_GKB7 database resources

**Table 92. &GKBZSCHM\_GKB7 database resources**

Version 8.3 Version 8.2 Version 1.1 qualifier	Table name	Version 8.3 Version 8.2 Version 1.1 tablespace (UTS)
&GKBZSCHM_GKB7	PRODUCT	WPROGKB

**Table 92. &GKBZSCHM\_GKB7 database resources (continued)**

<b>Version 8.3 Version 8.2 Version 1.1 qualifier</b>	<b>Table name</b>	<b>Version 8.3 Version 8.2 Version 1.1 tablespace (UTS)</b>
&GKBZSCHM_GKB7	TCOMPILER	WCPRGKB
&GKBZSCHM_GKB7	TPARAM	WPRMGKB
&GKBZSCHM_GKB7	TRODLINK	WPDKGKB
&GKBZSCHM_GKB7	TPRODUCT	WPDTGKB
&GKBZSCHM_GKB7	TPRSMAP	WPSMGKB
&GKBZSCHM_GKB7	TSCORPAT	WSCPGKB
&GKBZSCHM_GKB7	TVENDOR	WVDRGKB
&GKBZSCHM_GKB7	TVERSION	WVERGKB
&GKBZSCHM_GKB7	PRODUCT_SUITES	WPSUGKB
&GKBZSCHM_GKB7	TMODELS	WMODGKB

**&GKBZSCHM\_GKU7 database resources****Table 93. &GKBZSCHM\_GKU7 database resources**

<b>Version 8.3 Version 8.2 Version 1.1 qualifier</b>	<b>Table name</b>	<b>Version 8.3 Version 8.2 Version 1.1 table space (UTS)</b>
&GKBZSCHM_GKU7	TPARAM	WPSMGKU
&GKBZSCHM_GKU7	TPRODUCT	WPDTGKU
&GKBZSCHM_GKU7	TSCORPAT	WSCPGKU
&GKBZSCHM_GKU7	TVENDOR	WVDRGKU
&GKBZSCHM_GKU7	TVERSION	WVERGKU

**&GKBZSCHM\_IQF7 database resources****Table 94. &GKBZSCHM\_IQF7 database resources**

<b>Version 8.3 Version 8.2 Version 1.1 qualifier</b>	<b>Table name</b>	<b>Version 8.3 Version 8.2 Version 1.1 table space (UTS)</b>
&GKBZSCHM_IQF7	TCOMPILERS	WIQPCS
&GKBZSCHM_IQF7	TIQFILTERS	WIQFLS

**Table 94. &GKBZSCHM\_IQF7 database resources (continued)**

<b>Version 8.3 Version 8.2 Version 1.1 qualifier</b>	<b>Table name</b>	<b>Version 8.3 Version 8.2 Version 1.1 table space (UTS)</b>
&GKBZSCHM_IQF7	TPARAM	WIQPRM
&GKBZSCHM_IQF7	TXPCMODULES	WIQXMS
&GKBZSCHM_IQF7	TXPCSPEC	WIQXSC
&GKBZSCHM_IQF7	TXVENDORS	WIQXDR

**&REPZSCHM\_LKB7 database resources****Table 95. &REPZSCHM\_LKB7 database resources**

<b>Version 8.3 Version 8.2 Version 1.1 qualifier</b>	<b>Table name</b>	<b>Version 8.3 Version 8.2 Version 1.1 tables space (UTS)</b>
&REPZSCHM_LKB7	TPARAM	WPRMLKB
&REPZSCHM_LKB7	TPRODUCT	WPDTLKB
&REPZSCHM_LKB7	TSCORPAT	WSCPLKB
&REPZSCHM_LKB7	TVENDOR	WVDRLKB
&REPZSCHM_LKB7	TVERSION	WVERLKB

**&REPZSCHM\_LKU7 database resources****Table 96. &REPZSCHM\_LKU7 database resources**

<b>Version 8.3 Version 8.2 Version 1.1 qualifier</b>	<b>Table name</b>	<b>Version 8.3 Version 8.2 Version 1.1 table space (UTS)</b>
&REPZSCHM_LKU7	TPARAM	WPRMLKU
&REPZSCHM_LKU7	TPRODUCT	WPDTLKU
&REPZSCHM_LKU7	TSCORPAT	WSCPLKU
&REPZSCHM_LKU7	TVENDOR	WVDRLKU
&REPZSCHM_LKU7	TVERSION	WVERLKU

**&REPZSCHM database resources****Table 97. &REPZSCHM database resources**

<b>Version 8.3 Version 8.2 Version 1.1 qualifier</b>	<b>Table name</b>	<b>Version 8.3 Version 8.2 Version 1.1 table space (UTS)</b>
&REPZSCHM	NODE	VNODE
&REPZSCHM	NODE_CAPACITY	VNODECAP
&REPZSCHM	PRODUCT	VPRODUCT
&REPZSCHM	PRODUCT_INSTALL	VPRODINS
&REPZSCHM	PRODUCT_NODE_CAPACITY	VPRNOCAP
&REPZSCHM	PRODUCT_USE	VPRODUSE
&REPZSCHM	PRODUCT_USE_DETAIL	VPRODDET
&REPZSCHM	SYSTEM	VSYSTEM
&REPZSCHM	SYSTEM_NODE	VSYSNODE
&REPZSCHM	TACCOUNT	VACCOUNT
&REPZSCHM	TALTERNATE	VALTERNA
&REPZSCHM	TANNOTATE	VANNOTAT
&REPZSCHM	TCHANNEL_PATH	VCHANNEL
&REPZSCHM	TCONTROL_UNIT	VCONTROL
&REPZSCHM	TCSECT	VCSECT
&REPZSCHM	TISVEOS	VISVEOS
&REPZSCHM	TJOBDATA	VJOBDATA
&REPZSCHM	TLIBRARY	VLIBRARY
&REPZSCHM	TLIBSYS	VLIBSYS
&REPZSCHM	TLOGIQ	VLOGIQ
&REPZSCHM	TLOGUI	VLOGUI
&REPZSCHM	TLPAR	VLPAR
&REPZSCHM	TMACHINE_RESOURCE	VMACHINE
&REPZSCHM	TMODULE	VMODULE
&REPZSCHM	TPARAM	VPARAM
&REPZSCHM	TPERIODS	VPERIODS

**Table 97. &REPZSCHM database resources (continued)**

<b>Version 8.3 Version 8.2 Version 1.1 qualifier</b>	<b>Table name</b>	<b>Version 8.3 Version 8.2 Version 1.1 table space (UTS)</b>
&REPZSCHM	TPOVINV	VPOVINV
&REPZSCHM	TPOVLIB	VPOVLIB
&REPZSCHM	TPRODUCT	VTPRODUT
&REPZSCHM	TPRODUCT_REGISTRATION	VPRODREG
&REPZSCHM	TREGISTERED_PRODUCT_USAGE	VREGUSAG
&REPZSCHM	TUSEMTD	VUSEMTD
&REPZSCHM	TUSEPOV	VUSEPOV
&REPZSCHM	TUSEPOVLIB	VUPOVLIB
&REPZSCHM	TUSEPRS	VUSEPRS
&REPZSCHM	TUSERDATA	VUSRDATA
&REPZSCHM	TVENDOR	VVENDOR
&REPZSCHM	TVERSION	VVERSION
&REPZSCHM	PRODUCT_SUITES	VPRDSUIT
&REPZSCHM	ACTIVCON	VACTIVCN
&REPZSCHM	ACTIVPRD	VACTIVPR
&REPZSCHM	CONTCPU	VCONTCPU
&REPZSCHM	CONTLPAR	VCONTLPA
&REPZSCHM	CONTNER	VCONTNER
&REPZSCHM	TLICENSE	VLICENSE
&REPZSCHM	LICENSE_VERIFY	VLICENTL
&REPZSCHM	TLOGAGGR	VLOGAGGR
&REPZSCHM	TLOGLDEL	VLOGLDEL
&REPZSCHM	TLOGPDEL	VLOGPDEL

**Table 97. &REPZSCHM database resources (continued)**

<b>Version 8.3 Version 8.2 Version 1.1 qualifier</b>	<b>Table name</b>	<b>Version 8.3 Version 8.2 Version 1.1 table space (UTS)</b>
&REPZSCHM	TLOGUDEL	VLOGUDEL

# Chapter 11. Troubleshooting and support

To isolate and resolve problems with your IBM software, you can use the troubleshooting, messages, and support information. This information contains instructions for using the problem determination resources that are provided with your IBM products.

## Troubleshooting a problem

*Troubleshooting* is a systematic approach to solving a problem. The goal of troubleshooting is to determine why something does not work as expected and how to resolve the problem.

The first step in the troubleshooting process is to describe the problem completely. Problem descriptions help you and the IBM technical-support representative know where to start to find the cause of the problem. This step includes asking yourself basic questions:

- What are the symptoms of the problem?
- Where does the problem occur?
- When does the problem occur?
- Under which conditions does the problem occur?
- Can the problem be reproduced?

### What are the symptoms of the problem?

When starting to describe a problem, the most obvious question is "*What is the problem?*" This question might seem straightforward; however, you can break it down into several more-focused questions that create a more descriptive picture of the problem. These questions can include:

- Who, or what, is reporting the problem?
- What are the error codes and messages?
- How does the system fail? For example, is it a loop, hang, crash, performance degradation, or incorrect result?

The answers to these questions typically lead to a good description of the problem, which can then lead you a problem resolution.

Two main ways to approach any problem you encounter are understanding messages and using log files.

### Messages

Messages are issued when unexpected events occur. Messages can have any of these severities:

#### Informational

The message confirms an event that was requested or describes another normal occurrence. Informational messages generally do not require any action. The identifier of an informational message ends with the letter I.

**Warning**

The message describes an event that might indicate a problem. Read the message text and determine whether the event is normal or a problem. The identifier of a warning message ends with the letter W.

**Error**

The message describes an event that requires a response. Read the message description and the suggested response. The identifier of an error message ends with the letter E.

**Severe Error**

The message describes an event that requires a response. Read the message description and the suggested response. The identifier of an error message ends with the letter S.

**Unrecoverable Error**

The message indicates that an unrecoverable error was encountered and no requests were processed. Read the message description. The identifier of an error message ends with the letter U.

You can find a message description easily by entering its identifier into the Search box in the information center.

## Problems and solutions

Solution information helps you to understand the causes of an issue with your product and learn what to do to diagnose or resolve the problem.

### Resolving Db2 SQLCODE -805 error for DSNACLI plan

If you receive a SQLCODE -805 error, operational jobs fail.

**Symptoms**

IBM Z Software Asset Management operational jobs are failing.

**Causes**

The DSNACLI plan is not bound with the latest Db2® maintenance package, or the plan references a missing package.

**Diagnosing the problem**

Check the log files for error messages in the IBM Z Software Asset Management operational jobs. The following log entry provides an example of the failure of the DSNCLIQR package:

```
Native Error Code-805
{Db2 FOR OS/390}{ODBC DRIVER}{DSN10015}
DSNT408I SQLCODE = -805,
ERROR: DBRM OR PACKAGE NAME DBA2..DSNCLIQR.18F920E31-
3F8F1D9
NOT FOUND IN PLAN DSNACLI. REASON 03
```

## Resolving the problem

Rerun db2.SDSNSAMP(DSNTIJCL) for all packages that the DSNA CLI plan requires to be bound at the same time. The list of packages is slightly different for each release of Db2® for z/OS.

Ensure that the DSNAOCLI package has the following parameters:

```
BIND PACKAGE (DSNAOCLI) MEMBER(DSNCLIMS) -
  CURRENTDATA(YES) ENCODING(EBCDIC)
  SQLERROR(CONTINUE)
```

## Insufficient space in the Db2® work file database

When processing large amounts of data, you can encounter insufficient space in the Db2® work file database.

### Symptoms

IBM Z Software Asset Management operational jobs are failing.

### Causes

When you run SQL queries that process large amounts of data, including sorts and joins, there is insufficient space in the work file database that is used for temporary storage.

### Diagnosing the problem

Check for examples of following messages in the Db2® MSTR address space:

```
DSNT501I -DE91 DSNIWKFL RESOURCE UNAVAILABLE 553
CORRELATION-ID=XXXXXX
CONNECTION-ID=DB2CALL
LUW-ID=AUIBMQXP.OMU1DEC1.C4729058740C=0
REASON 00C900A5
TYPE 00000230
NAME 4K
DSNT501I -DE91 DSNIWKFL RESOURCE UNAVAILABLE 554
CORRELATION-ID=XXXXXX
CONNECTION-ID=DB2CALL
LUW-ID=AUIBMQXP.OMU1DEC1.C4729058740C=0
REASON 00C90084
TYPE 00000230
NAME 4K
```

View and check the sizes and extents of the physical data sets allocated to the table spaces in the work file database.

## Resolving the problem

Increase the sizes of the table spaces associated with the work file database. The sample db2.SDSNSAMP(DSNTIJTM) job provides examples of how to increase the sizes of the table spaces.

## Preventing Db2 timeouts/deadlocks during Inquisitor or Usage imports

Batch import jobs from the Inquisitor or the Usage Monitor require exclusive access to tables in the Repository database to prevent timeouts or deadlocks.

### Symptoms

IBM Z Software Asset Management operational jobs for Inquisitor or Usage import are failing.

When running Inquisitor Import or Usage import batch jobs, multiple users using the Analyzer to access the Repository database can lead to timeouts or deadlocks. These batch jobs require exclusive accesses to the data in the tables. SQLCODE -904 error occurs with reason code 00C90083 or reason code 00C9008E.

### Causes

When running Inquisitor Import or Usage import batch jobs, multiple users using the Analyzer to access the Repository database can lead to timeouts or deadlocks. These batch jobs require exclusive accesses to the data in the tables. SQLCODE -904 error occurs with reason code 00C90083 or reason code 00C9008E

### Diganosing the problem

Check for examples of following messages in the Db2@ MSTR address space:

```
DSNT501I - DSNIDBET RESOURCE UNAVAILABLE 656
CORRELATION-ID=AAAAAA
CONNECTION-ID=DB2CALL
LUW-ID=NETA.GGGGGG.UUUUD99=81188
REASON 00C90083
TYPE 00000200
NAME XXXXXX.YYYYY

DSNT501I - DSNIDBET RESOURCE UNAVAILABLE 656
CORRELATION-ID=BBBBB
CONNECTION-ID=DB2CALL
LUW-ID=NETA.GGGGGG.IIIII222=81188
REASON 00C9008E
TYPE 00000200
NAME XXXXXX.YYYYY
```

### Resolving the problem

You can perform one or more of the following changes to resolve the issue:

- Run these jobs during off-peak periods.
- Reduce the number of users that need to use the Analyzer during peak periods.
- Reduce the value of the COMMIT=1000 attribute to COMMIT=500 in PARMLIB members HSIQIP1 and HSISUIP1.
- Define the DSNACLI plan and the dependent packages to use uncommitted reads.

- Modify all packages and plan in db2.SDSNSAMP(DSNTIJCL) to have ISOLATION(UR) and then run the job.
- When you change the settings for DSNACLI, ensure that this plan is not used by other applications or create the plan with a different name.
- By setting ISOLATION(UR), when you run Analyzer reports, it is likely that the correct or latest information is not be displayed due to concurrency issues in Db2®.

## Improving Db2 performance

For DB2 sites, IBM Z Software Asset Management operational jobs are usually run during off-peak so it is important that all IQ Import and Usage Import jobs must complete during the batch window.

### Symptom

- Operational jobs such as IQ Import and Usage Import seem to be taking longer to run.
- Reports retrieved via the Analyzer also seem to take longer to finish.

### Causes

This issue can occur for the following reasons:

- Retaining too much usage data for long periods and not performing regular housekeeping tasks.
- Importing all usage data into a single repository instead of spreading the usage data across multiple repositories.

### Diagnosing the problem

- Identify operational jobs that are now taking longer to run.
- Identify Analyzer reports that are now taking longer to finish.
- In the Db2 MSTR address space/system console, check for any DSNJ031I or DSNR035I messages, indicating that jobs may not be committing at regular intervals as expected.
- In the Db2 MSTR address space/system console, check for problems related to the Db2 work file database (this has been covered in a previous problem/solution).
- Run SQL command to determine size and periods of the largest table – TUSEMTD
- Run SQL command to list libraries that are marked deleted (obsolete).
- IBM Support may request you to run special diagnostics/traces.
- Run SQL command to determine size and periods of the largest table – TUSEMTD

```
SELECT FPERIOD, COUNT(*) FROM &RESPZSCHM.TUSEMTD
GROUP BY FPERIOD ;
```

Next review comments in job HSISLDEL and decide on range of periods to select for deletion of usage records.

- Run SQL command to list libraries that are marked deleted (obsolete).

```
SELECT DISTINCT CAST(YEAR(FOBSERVEDELETED)AS CHAR(4))||
'-'||CASE WHEN MONTH(FOBSERVEDELETED)< 10
THEN '0'
ELSE " END || CAST(MONTH(FOBSERVEDELETED)
```

```
AS CHAR(2))
FROM &REPZSCHM.TLIBRARY
WHERE FOBSERVEDELETED IS NOT NULL;
```

The above SQL command is found in job, HSISPDEL. Review comments in the job and decide on range of periods to select for deletion of obsolete records from the TLIBRARY, TLIBSYS, TMODULE, TUSEPOV, and TCSECT tables.

- Run job HSISLDEL to delete obsolete LPARs (LPARs that have been decommissioned at your site).
- For sites that have an extremely large TUSEMTD table (50m to 100m rows per period), consider defining the table space as a partition-by-range (PBR) UTS. Use column FPERIOD in TUSEMTD table as the key for the range. As this is not a trivial task, the DBA needs to prepare an implementation plan for this exercise to convert from a PBG to a PBR.
- On a regular basis, run REORG for all repositories. RUNSTATS is automatically run as part of IQ Import and Usage Import jobs.

## Resolving the problem

For Analyzer reports, especially from the Discovery Tab, do not use an '\*' as the first character as a wild card. For example, in report 'Search by Modules, restrict your search to a more definitive range.

As part of improving the run times, you may be advised by IBM Support to change the value for the COMMIT parameter required in the IQ Import and Usage Import jobs.

## Updating your Global Knowledge Base (GKB) database

IBM support provides monthly update to the Global Knowledge Base (GKB). so that you can keep your product inventory definitions up-to-date. You can also submit items to IBM support for inclusion in GKB updates.

### Symptoms

Products displayed in the Analyzer reports are not correct.

### Causes

The GKB database does not contain the latest updates.

### Diagnosing the problem

To verify the latest version of the GKB database, check the log in HSISIQIM job for GKB Version = *yyymmdd*. The *yyymmdd* variable represents the version of GKB monthly update that is applied at your site.

## Resolving the problem

Refer to the section [Updating the Global Knowledge Base on page 61](#) on how to download and update the latest copy of the GKB database.

# Chapter 12. IBM Z Software Asset Management messages

You can identify the type of message by the message prefix.

## HSIA - Automation Server messages

### Return codes

**Table 98. Return codes and their meaning**

Return code	Description
0	No errors encountered. All requests processed successfully.
16	Unrecoverable error. No requests processed. SYSIN or HZAPZIP or INQSOUT File cannot be used, or unsupported operating system.

### Message suffix codes

**Table 99. Message suffix codes and associated condition codes**

Suffix	Meaning	Raises minimum condition code to:
I	Information message	0
W	Warning message	4
E	Error message	8
S	Severe error message	12
U	Unrecoverable error message	16, 20

### Message texts and explanations

All numeric completion codes of system services reported in these messages are in hexadecimal unless otherwise stated.

---

**HSIA001E** EXPECTED CLOSE PARENTHESIS WAS NOT FOUND IN INPUT RECORD

**Explanation:** Parsing did not detect the expected close parenthesis.

**System action:** Terminates the processing of the HSIAPARM member contents.

**Operator response:** Correct the HSIAPARM member contents.

**System programmer response:** None.

**Module:** HSIAUTO HSIADSN

---

**HSIA002E** EXPECTED VALUE FOR *parm* NOT FOUND BEFORE THE CLOSE PARENTHESIS

**Explanation:** No subparameter value was specified within the parentheses. In the message text:

*parm*

name of parameter being processed.

**System action:** Terminates the processing of the HSIAPARM member contents.

**Operator response:** Correct the HSIAPARM member contents.

**System programmer response:** None.

**Module:** HSIAUTO HSIADSN

---

**HSIA003E** THE *parm* PARAMETER IS NOT RECOGNIZED

**Explanation:** A parameter was detected which is not valid for the type of statement being processed. In the message text:

*parm*

name of parameter being processed.

**System action:** Terminates the processing of the HSIAPARM member contents.

**Operator response:** Correct the HSIAPARM member contents.

**System programmer response:** None.

**Module:** HSIAUTO

---

**HSIA004E** THE VALUE SPECIFIED FOR *parm* IS INVALID

**Explanation:** The named parameter had a value which did not conform to syntax requirements. In the message text:

*parm*

name of parameter being processed.

**System action:** Terminates the processing of the HSIAPARM member contents.

**Operator response:** Correct the HSIAPARM member contents.

**System programmer response:** None.

**Module:** HSIAUTO

---

**HSIA005E** NO "FTP" OR "JOB" STATEMENT BEFORE "DSN" STATEMENT

**Explanation:** There is no preceding action to relate the dsname mask to.

**System action:** Terminates the processing of the HSIAPARM member contents.

**Operator response:** Correct the HSIAPARM member contents.

**System programmer response:** None.

**Module:** HSIAUTO HSIADSN

---

**HSIA006E** *parm* IS AN UNRECOGNIZED STATEMENT TYPE

**Explanation:** A statement type other than FTP, JOB, or DSN was specified. In the message text:

*parm*

name of parameter.

**System action:** Terminates the processing of the HSIAPARM member contents.

**Operator response:** Correct the HSIAPARM member contents.

**System programmer response:** None.

**Module:** HSIAUTO HSIADSN

---

**HSIA007E** TERMINATING - AUTOMATION SERVER IS ALREADY ACTIVE

**Explanation:** The Automation Server is already running. Only one concurrent copy can run in an operating system image.

**System action:** Program terminates with condition code 16. The established Automation Server continues.

**Operator response:** None.

**System programmer response:** None.

**Module:** HSIAUTO

---

**HSIA008E** TERMINATING - COULD NOT INITIALISE WITH BAD PARAMETERS

**Explanation:** The HSIAPARM contents contained an error so the Automation Server could not initialize.

**System action:** The program terminates with condition code 16.

**Operator response:** Correct the HSIAPARM member contents.

**System programmer response:** None.

**Module:** HSIAUTO HSIADSN

---

**HSIA009E** REFRESH IGNORED - COULD NOT PROCESS BAD PARAMETERS

**Explanation:** The HSIAPARM contents contained an error so the Automation Server could not update its operational parameters.

**System action:** Terminates the processing of HSIAPARM contents.

**Operator response:** Correct the HSIAPARM member contents.

**System programmer response:** None.

**Module:** HSIAUTO HSIADSN

---

**HSIA010E** NO FUNCTIONS WERE REQUESTED

**Explanation:** No actions were specified. The Automation Server has no work to do.

**System action:** Terminates the processing of HSIAPARM contents.

**Operator response:** Correct the HSIAPARM member contents.

**System programmer response:** None.

**Module:** HSIAUTO HSIADSN

---

**HSIA011E** NO DATA SET NAME MASKS WERE SPECIFIED

**Explanation:** No work was requested. The Automation Server has no work to do.

**System action:** Terminates the processing of HSIAPARM contents.

**Operator response:** Correct the HSIAPARM member contents.

**System programmer response:** None.

**Module:** HSIAUTO HSIADSN

---

**HSIA012E** NUMBER OF ACTIONS EXCEEDS MAXIMUM OF 1000

**Explanation:** Too many actions were requested.

**System action:** Terminates the processing of HSIAPARM contents.

**Operator response:** Reduce the number of actions specified.

**System programmer response:** None.

**Module:** HSIAUTO HSIADSN

---

**HSIA013E**           NUMBER OF DATA SET NAME MASKS EXCEEDS THE MAXIMUM OF 2000

**Explanation:** Too many dataset name masks were specified.

**System action:** Terminates the processing of HSIAPARM contents.

**Operator response:** Reduce the number of dataset name masks.

**System programmer response:** None.

**Module:** HSIAUTO HSIADSN

---

**HSIA014E**           MEMBER *mbr* WAS NOT FOUND IN THE HSIACNTL FILE

**Explanation:** Member HSIAPARM was found to be missing from the HSIACNTL file. In the message text:

*mbr*

name of missing member.

**System action:** Terminates the processing of the member. If the member is HSIAPARM the Automation Server terminates. For template members the Automation Server continues processing.

**Operator response:** Create the required member in the HSIACNTL library.

**System programmer response:** None.

**Module:** HSIAUTO HSIADSN

---

**HSIA015E**           INPUT LOGICAL RECORD LENGTH WAS NOT 80

**Explanation:** A record was read from the HSIACNTL library which was not 80 bytes long.

**System action:** The program terminates and takes no actions.

**Operator response:** Ensure the HSIACNTL library only contains fixed length 80 byte records.

**System programmer response:** None.

**Module:** HSIAUTO HSIADSN

---

**HSIA016E**           EXPECTED OPEN PARENTHESIS WAS NOT FOUND IN INPUT RECORD

**Explanation:** Parsing did not detect the expected open parenthesis.

**System action:** Terminates the processing of the HSIAPARM member contents.

**Operator response:** Correct the HSIAPARM member contents.

**System programmer response:** None.

**Module:** HSIAUTO

---

**HSIA017E** VALUE SPECIFIED FOR *parm* IS TOO LONG

**Explanation:** A parameter value was specified which has a length greater than the maximum allowed for the named parameter. In the message text:

*parm*

name of parameter.

**System action:** Terminates the processing of the HSIAPARM member contents.

**Operator response:** Correct the HSIAPARM member contents.

**System programmer response:** None.

**Module:** HSIAUTO HSIADSN

---

**HSIA018E** THE "NOTA" VALUE IS LESS THAN THE "NOTB" VALUE

**Explanation:** The action can never be performed because all days of the month have been excluded by the combination of the NOTA (not after) and NOTB (not before) specifications.

**System action:** Terminates the processing of the HSIAPARM member contents.

**Operator response:** Correct the HSIAPARM member contents.

**System programmer response:** None.

**Module:** HSIAUTO

---

**HSIA019I** AUTOMATION SERVER INITIALIZATION COMPLETE

**Explanation:** The Automation Server is commencing normal operations.

**System action:** Processing continues.

**Operator response:** None.

**System programmer response:** None.

**Module:** HSIAUTO

---

**HSIA020I** AUTOMATION SERVER HAS NOW TERMINATED

**Explanation:** The Automation Server is ceasing normal operations.

**System action:** Processing concludes.

**Operator response:** None.

**System programmer response:** None.

**Module:** HSIAUTO

**HSIA999U** HSIMSG/HSIAMSG FAILURE - MSGID=*msgid* RC=*rc* RS=*rs*

**Explanation:** HSIMSG was called to produce a message text, but the call failed. In the message text:

***msgid***

identifier of the failing message.

***rc***

HSIMSG return code.

tm 1302745957 0

## HSIC - Operation messages

These messages are issued by the HSIC - Computation phase.

### Return codes

**Table 100. Return codes and their meaning**

Return code	Description
0	No errors encountered. All requests processed successfully.
16	Unrecoverable error. No requests processed. SYSIN or HSIPZIP or INQSOUT File cannot be used, or unsupported operating system.

### Message suffix codes

**Table 101. Message suffix codes and associated condition codes**

Suffix	Meaning	Raises minimum condition code to:
I	Information message	0
W	Warning message	4
E	Error message	8
S	Severe error message	12
U	Unrecoverable error message	16

### Message texts and explanations

All numeric completion codes of system services reported in these messages are in hexadecimal unless otherwise stated.

---

**HSIC002E**            A message is missing from the internal repository

**Explanation:** A message is missing from the internal message repository. When the default language is not English, the translation of the given message might not exist. If the default language is English, the message indicates an error in the given application.

**System action:** The application would normally continue ignoring the given message number, but the specific action depends on the code attempting to issue the message, which could also terminate the application.

**User response:** Contact IBM support.

---

**HSIC003U**            The internal message repository is corrupted

**Explanation:** When attempting to issue a message, the internal message repository layout did not follow the expected format.

**System action:** The application terminates.

**User response:** Contact IBM support.

---

**HSIC020E**            *application-name* encountered errors. Error code = *errorcode*

**Explanation:** The Application has encountered errors during processing. This is a general message on completion indicating that an error has occurred.

**System action:** Completes with given error code.

**User response:** Refer to additional message, or to the section 6016, and to the log for more details on the specific error. Contact IBM support.

---

**HSIC021S**            *application-name* encountered fatal errors. Error code = *error-code*

**Explanation:** The application has encountered fatal errors during processing.

**System action:** Terminates with given error code.

**User response:** Refer to additional message, or to the section 6016, and to the log for more details on the specific error. Contact IBM support.

---

**HSIC023E**            Inquisitor Import error occurred in opening: *filename*

**Explanation:** The Inquisitor Import could not open the given file.

**System action:** Terminates without processing any records.

**User response:** Check that the file exists, and if it does, check for any additional log message identifying the error. Contact IBM support.

---

**HSIC024E** Inquisitor Import input file is in error. It looks like a usage data file

**Explanation:** The Inquisitor Import has encountered an invalid input file.

**System action:** Terminates without processing any records.

**User response:** Check that the input file is a valid file. Contact IBM support.

---

**HSIC025E** Inquisitor Import input file is in error. It looks like a hardware data file

**Explanation:** The Inquisitor Import has encountered an invalid input file.

**System action:** Terminates without processing any records.

**User response:** Check that the input file is a valid file. Contact IBM support.

---

**HSIC026E** Inquisitor Import detected that table *tablename* is missing or invalid

**Explanation:** The expected table is missing from the database or has invalid format. This suggests a mismatch between the database and this version of the product.

**System action:** Terminates without processing any records.

**User response:** Check for a version mismatch between the database and the version of the product. Contact IBM support.

---

**HSIC027S** Inquisitor Import table *tablename* is missing a column

**Explanation:** The given table is missing an expected column. This suggests a mismatch between the database and this version of the product.

**System action:** The application terminates without processing any records.

**User response:** Check for a version mismatch between the database and the version of the product. Contact IBM support.

---

**HSIC028S** Inquisitor Import table *tablename* appears to be an old version

**Explanation:** The given table in the database does not have the expected format.

**System action:** The application terminates without processing any records.

**User response:** Check for a version mismatch between the database and the version of the product. Contact IBM support.

---

**HSIC029S** Inquisitor Import error when writing to table *tablename*

**Explanation:** An SQL error occurred when attempting to write to the given table.

**System action:** The application terminates.

**User response:** Check the log for additional details about the given error. Contact IBM support.

---

**HSIC030S** The Inquisitor Import did not find a valid system header record in the input file

**Explanation:** The input file does not follow the expected format.

**System action:** The application terminates.

**User response:** Check that the correct input file is supplied and that there is no version mismatch. Contact IBM support.

---

**HSIC034S** Error reading Repository TPARAM table

**Explanation:** An error occurred while reading the TPARAM Repository table.

**System action:** The application terminates.

**User response:** Check the log for any additional messages indicating the cause of the error. Contact IBM support.

---

**HSIC035E** The Repository is in use by the *application-name*

**Explanation:** The application cannot run because the Repository is already in use by another application. Wait until *application-name* completes before running the current application. If the Repository is not in use by *application-name*, then the cause could be that it was previously run, but did not run to completion. To correct the problem, either rerun the *application-name* identified in this message, or alternatively, run the supplied HSISTPRM job to reset FVALUE to 0 where FKEY = PROCRUN in the TPARAM table.

**System action:** The application terminates.

**User response:** Check that the application is not already in use before running this application.

---

**HSIC036E** Syntax error scanning TPARAMS file on line *linenumber*

**Explanation:** The TPARAM file does not conform to the required syntax on the given line.

**System action:** The specified option or value is ignored, and its default value is used where applicable.

**User response:** Check that valid options/values are supplied as specified in the documentation of the application that you are running.

---

**HSIC037E** Schema *schemavalue* is too long in param *param*

**Explanation:** A schema ID that is too long has been specified.

**System action:** The application terminates.

**User response:** Check that the schema ID does not exceed 8 characters in length.

---

**HSIC038E** Unbalanced quote for value: *value* in param:*param*

**Explanation:** A starting quote that has no matching end quote was found for the given parameter.

**System action:** The application terminates.

**User response:** Check that the given parameter has matching quotes.

---

**HSIC039E** Illegal character in value:*value* of param:*param*

**Explanation:** An invalid character was found in the given value.

**System action:** The application terminates.

**User response:** Check that the given parameter value is valid for its type.

---

**HSIC040E** Reserved word: *reservedword* in param: *param*

**Explanation:** A reserved word or system value schema ID was chosen as a parameter value.

**System action:** The application terminates.

**User response:** Specify a different parameter value.

---

**HSIC041W** value:*value* in param:*param* is not a recommended schema ID

**Explanation:** The value is not recommended because of possible conflicts with existing values.

**System action:** The application continues.

**User response:** Choose a different value to avoid conflicts.

---

**HSIC042E** TPARAM file: param:*param* has an invalid proposed value: *value*

**Explanation:** The parameter cannot be set to the given value because the value is not valid.

**System action:** The value is ignored, and the application continues.

**User response:** Choose a valid value as per the documentation of the given application.

---

**HSIC043E**           The application has failed to open the TPARAM file. Error: *errordescription*

**Explanation:** The application could not open the TPARAM file. The error description contains more details regarding the reason for the error.

**System action:** The application terminates.

**User response:** Check that the TPARAM file exists and is valid.

---

**HSIC045E**           String *string* cannot exceed *numberchars* in length

**Explanation:** A parameter length limit has been exceeded.

**System action:** The application terminates.

**User response:** Ensure that the specified parameter length is not exceeded.

---

**HSIC050E**           The *program-name* program has detected an invalid date parameter

**Explanation:** A date parameter was found to be invalid.

**System action:** The application terminates.

**User response:** Ensure that the date format is valid, and start dates do not overlap end dates.

---

**HSIC051S**           Error adding record

**Explanation:** An SQL error occurred when adding a record to a table.

**System action:** The application terminates.

**User response:** Check the log for additional information about the error. Contact IBM support.

---

**HSIC052S**           Error updating record

**Explanation:** An SQL error occurred when updating a record in a table.

**System action:** The application terminates.

**User response:** Check the log for additional information about the error. Contact IBM support.

---

**HSIC053S**           Error deleting record

**Explanation:** An SQL error occurred when deleting a record from a table.

**System action:** The application terminates.

**User response:** Check the log for additional information about the error. Contact IBM support.

---

**HSIC055S**            Table initialization failure during Repository Merge

**Explanation:** At least one table initialization failed when merging repositories.

**System action:** The application terminates.

**User response:** Check the log for any additional details about this error. Contact IBM support.

---

**HSIC056S**            Some table destination fields are smaller than source

**Explanation:** Some fields in the target repository are not large enough to fit the contents of fields in the source repository.

**System action:** The application terminates, and the repositories are not merged.

**User response:** Check that the destination repository is not an older version than the source repository. You can recreate the destination repository using the latest version of the product. If the problem persists, contact IBM support.

---

**HSIC057E**            A value for parameter: *parameter-name* must be specified

**Explanation:** A mandatory parameter for this application has not been specified.

**System action:** The application terminates during the syntax checking of input parameters.

**User response:** Ensure that a value for the given parameter is specified. Refer to the documentation of the failing application for an explanation of the given parameter and/or valid parameter values.

---

**HSIC058E**            Could not open *filename*

**Explanation:** File could not be opened.

**System action:** The application terminates.

**User response:** Check the log for additional information about the error. Contact IBM support.

---

**HSIC059E**            Could not read *filename*

**Explanation:** File could not be read.

**System action:** The application terminates.

**User response:** Check the log for additional information about the error. Contact IBM support.

---

**HSIC060E** IQDATA DD does not contain unzipped IQ data

**Explanation:** The input IQDATA dataset does not contain unzipped IQ data.

**System action:** The application terminates.

**User response:** Check the log for additional information about the error. Contact IBM support.

---

**HSIC061E** Internal error hcreate(*number*) phase1a failed

**Explanation:** An internal error has occurred.

**System action:** The application terminates.

**User response:** Check the log for additional information about the error. Contact IBM support.

---

**HSIC062E** No SMF 30-2 or 30-4 data matched IQ data

**Explanation:** No match was found for the SMF data and IQ data.

**System action:** The application terminates.

**User response:** Check that the correct data sets have been used. Contact IBM support.

---

**HSIC063E** Internal error hsearch(*key*) table add failed

**Explanation:** An error occurred when inserting data into a table.

**System action:** The application terminates.

**User response:** Check the log for additional information about the error. Contact IBM support.

---

**HSIC064E** Could not write *type* to FMOUT

**Explanation:** Could not write to file FMOUT.

**System action:** The application terminates.

**User response:** Check the log for additional information about the error. Contact IBM support.

---

**HSIC065E** SYSUT1 data is not IQ text or UM text

**Explanation:** The SYSUT1 dataset does not contain the expected data.

**System action:** The application terminates.

**User response:** Check that the SYSUT1 dataset is correct. Contact IBM support.

---

**HSIC066E** Internal error hsearch(*key*) table failed

**Explanation:** An error occurred when retrieving data from a table.

**System action:** The application terminates.

**User response:** Check the log for additional information about the error. Contact IBM support.

---

**HSIC067E** Unable to acquire storage

**Explanation:** An error has occurred when attempting to acquire storage.

**System action:** The application terminates.

**User response:** Try increasing the region size specified in the region parameter on the JOB or EXEC statement in the JCL for the job. Contact IBM support.

---

**HSIC068E** IBMMOD Internal error

**Explanation:** An internal error has occurred.

**System action:** The application terminates.

**User response:** Check the log for additional information about the error. Contact IBM support.

---

**HSIC069E** IBMMOD\_INIT internal error

**Explanation:** An error occurred when retrieving data from a table.

**System action:** The application terminates.

**User response:** Check the log for additional information about the error. Contact IBM support.

---

**HSIC070I** A full rematch will be performed

**Explanation:** A full import and rematch will be performed, which will not try to exclude modules of unchanged libraries. The default behavior is to exclude such libraries from matching, which would normally lead to faster processing.

The program performs a full rematch, if any of the following is true :

- If requested by the FULLREMATCH option.
- When the specified inventory is not found, for example on the first run when the inventory has not yet been created, and no previous match was done.
- If it is safer to perform a full rematch, as when a GKB change is detected or the REPLACEFULL option is in effect.

More specific details on why a full rematch is being performed, can be found in the log.

**System action:** A full rematch of the data is performed. All libraries are processed.

**User response:** Ensure that a FULLREMATCH and the REPLACEFULL options are not in effect for better performance, unless a full rematch is desired. If this is the first run of the Inquisitor Import, or there has been recent a change to the GKB, then no action is necessary; the program will try on subsequent runs (subsequent to loading the current data into the repository) to exclude unchanged libraries.

---

**HSIC0711**            *&number\_modules* modules in *&number\_libraries* unchanged libraries were ignored

**Explanation:** This is a report of the number of the modules and libraries that are ignored when the FULLREMATCH option is not in effect. Details of these ignored libraries are in the log.

**System action:** None.

**User response:** None.

---

**HSIC073E**            Usage Import for system *SID* on *time* is a duplicate and will be ignored.

**Explanation:** This input file has already been processed.

**System action:** The file is not processed. Processing is terminated.

**User response:** Provide an input file that is the output of a more recent Usage Monitor output.

---

**HSIC074E**            IQ input file dated *time1* is earlier than the latest *os\_type* scan for SID *sid* dated *time2*.

**Explanation:** The input file is earlier than an an input file that was already processed for this system.

**System action:** The file is not processed. Processing is terminated.

**User response:** Provide an input file that is the output of a more recent Inquisitor scan.

---

**HSIC075I**            *num\_libs* libraries containing *num\_modules* modules are mirrors.

**Explanation:** The program encountered mirror libraries, which are libraries that are identical in name and volume to libraries that the program previously processed on different SIDs.

**System action:** The program records the names and locations of such libraries but does not process their contents of modules. The program displays the names of such libraries in the log, as well as their current and base SIDs.

**User response:** This operation is normal as long as the repository is set up correctly to receive SIDs containing libraries that are unique in library and volume name except when they are copies or shared, and no other SIDs that do not conform to these rules were mistakenly placed into the repository. Refer to the Inquisitor Import description for more information. Refer to the log for a list of mirror libraries and their base SIDs. You can run the System Deletion Job to remove any SIDs that have been placed recently but incorrectly into this repository.

---

**HSIC076I**            IQ input file dated *time* is a duplicate of the last *OS\_TYPE* scan for SID *SID\_NAME*.

**Explanation:** This input file has already been processed.

**System action:** The program continues and the file is processed.

**User response:** None.

---

**HSIC077I**            Analyzer initialization complete.

**Explanation:** The Analyzer has started.

**System action:** Processing continues.

**User response:** None.

---

**HSIC078I**            Analyzer has now terminated.

**Explanation:** The Analyzer has stopped.

**System action:** Processing continues.

**User response:** None.

---

**HSIC079I**            Analyzer is unable to display URL because gethostname returned a null string for the host  
name.

**Explanation:** The analyzer attempted to get the host name of the system it is running on using the z/OS C/C++ gethostname library function and a null string was returned. This may happen if the TCP/IP TCPIP.DATA configuration file does not have a HOSTNAME statement.

**System action:** The analyzer is unable to display the url that clients can use to access it in its log. The analyzer continues processing and listening for connections from clients.

**User response:** Add a HOSTNAME statement to the TCP/IP TCPIP.DATA configuration file. In order for this change to have an effect, the TCP/IP address space must be stopped and restarted. Refer to the *z/OS Communications Server: IP Configuration Reference* for more information on the HOSTNAME statement, on the TCPIP.DATA configuration file, and how to modify them.

---

**HSIC080I**            Analyzer is unable to display URL because getaddrinfo for host *hostName* failed with errno

**Explanation:** The analyzer attempted to get the fully qualified domain name and IP address for the host it is running on, which is named *hostName*. The z/OS C/C++ getaddrinfo library function was used, and it returned the error number shown.

**System action:** The analyzer is unable to display the URL that clients can use to access it in its log. The analyzer continues processing and listening for connections from clients.

**User response:** Refer to the *z/OS Communications Manager: IP and SNA Codes* manual for a description of Resolver return codes. It is possible that the host name could not be resolved due to a Resolver configuration problem or a Domain Name System (DNS) configuration problem. Refer to *z/OS Communications Server: IP Configuration Guide* and the *z/OS Communications Server: IP Configuration Reference* for information about how to configure Resolver and the BIND 9-based Domain Name System.

---

**HSIC081E** Incompatible GKB level for gkb schema: *schema*. Expected level: *expected\_level\_number*,  
received: *received\_level\_number*.

**Explanation:** A mismatch between the GKB level and the level expected by the program was found. This indicates that the GKB and the code are at different maintenance levels. If the *received\_level\_number* is greater than the *expected\_level\_number*, it indicates that a later level of the GKB is used than can be handled by the current maintenance level of the code. If the *received\_level\_number* is less than the *expected\_level\_number*, it indicates that an old level of the GKB, that can no longer be handled by the current maintenance level of the code, is used.

**System action:** The application terminates.

**User response:** Apply GKB and code maintenance to the indicated GKB schema as required to ensure code and GKB are compatible. Contact IBM support for further assistance.

---

**HSIC082E** Incompatible repository level for repository schema: *schema*. Expected  
level: *expected\_level\_number*, received: *received\_level\_number*.

**Explanation:** A mismatch between the Database repository level and the level expected by the program was found. This indicates that the repository and the code are at different maintenance levels. If the *received\_level\_number* is greater than the *expected\_level\_number*, it indicates that a later level of the repository is used than can be handled by the current maintenance level of the code. If the *received\_level\_number* is less than the *expected\_level\_number*, it indicates that an old level of the repository, that can no longer be handled by the current maintenance level of the code, is used.

**System action:** The application terminates.

**User response:** Apply Database repository and code maintenance to the indicated repository schema as required to ensure code and repository are compatible. Contact IBM support for further assistance.

---

**HSIC083I** GKB schema: *schema* of version date: *gkb\_date* is out of date. It is more than *number of  
months old*.

**Explanation:** The used GKB of the given schema name is likely to be superseded and can be replaced by a more recent GKB containing more product updates. The GKB that is used is older than the default value of the *number\_of\_months* from the current date which means the latest identification changes may be missed.

**System action:** The application continues.

**User response:** Apply GKB maintenance as soon as possible.

---

**HSIC084E** GKB schema: *schema* is missing configuration parameters.

**Explanation:** The used GKB of the given schema name is missing configuration parameters that the program needs. This is most likely to occur if the GKB has not been loaded successfully.

**System action:** The application terminates.

**User response:** Ensure GKB is loaded successfully. Contact IBM support if the problem persists.

---

**HSIC085E** GKB schema: *schema* does not have any scorecards.

**Explanation:** The used GKB of the given schema name does not have any scorecards that can be used to match discovered modules. This is most likely to occur if the GKB has not been loaded successfully.

**System action:** The application terminates.

**User response:** Ensure GKB is loaded successfully. Contact IBM support if the problem persists.

---

**HSIC086S** SCRT Import detected a configuration error.

**Explanation:** An error occurred while reading the TPARAM dataset.

**System action:** The application terminates.

**User response:** Check the log for any additional messages indicating the cause of the error. Contact IBM support.

---

**HSIC087E** SCRT Import detected an input data error.

**Explanation:** The SCRT CSV file is invalid or does not follow the expected format.

**System action:** The application terminates.

**User response:** Check the log for additional information about the error. Contact IBM support.

---

**HSIC088E** SCRT Import detected a database error.

**Explanation:** An SQL error occurred.

**System action:** The application terminates.

**User response:** Check the log for additional information about the error. Contact IBM support.

---

**HSIC089W** Hardware serial *serial* does not exist in the Z SW Asset Mgmt database.

**Explanation:** The hardware serial has not been discovered by Inquisitor Import or Usage Monitor.

**System action:** The application continues; SCRT data will not be imported for this hardware serial.

**User response:** Ensure Inquisitor Import and Usage Monitor are run for the desired hardware serial prior to running SCRT Import.

---

**HSIC090W**      The following Systems do not exist in the Z SW Asset Mgmt database: *systems*

**Explanation:** The systems have not been discovered by Inquisitor Import or Usage Monitor.

**System action:** The application continues; SCRT data will not be imported for the systems.

**User response:** Ensure Inquisitor Import and Usage Monitor are run for the desired systems prior to running SCRT Import.

---

**HSIC091W**      The following Products do not exist in the current GKB: *products*

**Explanation:** The products could not be located in the current GKB.

**System action:** The application continues; SCRT data will not be imported for the products.

**User response:** Contact IBM support, supply the missing products information from the log, and request a GKB refresh.

---

## Error codes

---

**6016**            Input text file open error

---

**6060**            Input Parameter error

---

**6061**            Database open error

---

**6062**            Database commit error

---

**6063**            Error reading repository TPARAM table

---

**6065**            Repository is in use

---

**6066**            Unknown SID parameter value

---

**6067**            SQL error

---

**6068**            Expected parameter missing from the TPARAM table

---

**6069**            Specified SID is not found

---

---

<b>6070</b>	Invalid data was encountered
<b>6071</b>	Usage Import file is duplicate
<b>6072</b>	IQ Import file is duplicate or of earlier date
<b>6073</b>	File read error
<b>6074</b>	GKB level is unsupported
<b>6075</b>	Repository level is unsupported
<b>6076</b>	GKB is missing configuration parameters
<b>6077</b>	GKB is missing scorecards
<b>6203</b>	Inquisitor Import table open fail
<b>6204</b>	MVS™ system header record not found in input file
<b>6205</b>	Unix System Services header record not found in input file
<b>6206</b>	No system header record found in input file
<b>6208</b>	Error writing to TPARAM table
<b>6209</b>	Error opening input file
<b>6211</b>	Fatal error writing system record
<b>6212</b>	Fatal error writing library record
<b>6213</b>	Fatal error writing module record

---

---

<b>6218</b>	Input file looks like a usage data file
<b>6219</b>	Input file looks like a hardware data file
<b>6220</b>	Index missing error
<b>6221</b>	Vendor product version table processing error
<b>6223</b>	Error encountered when retrieving the inventory ID
<b>6224</b>	Error encountered when retrieving the current GKB version
<b>6225</b>	Error encountered when retrieving the inventory GKB version
<b>6237</b>	Inquisitor Import table does not exist or is missing a column
<b>6238</b>	Inquisitor Import table does not exist
<b>6239</b>	Inquisitor Import table appears to be an old version
<b>6240</b>	Error updating fGPassLibID record
<b>6241</b>	Error deleting empty libraries
<b>6244</b>	Error assigning package information to TMODULE records
<b>6260</b>	Nothing to import, as no module records were found in IQ file
<b>6400</b>	Knowledge Base type is incorrect
<b>6402</b>	Failure in initializing IQ tables
<b>6403</b>	IQ TMODULE open error

---

---

<b>6404</b>	IQ TMODULE index error
<b>6405</b>	IQ database is empty
<b>6409</b>	TDECISION table open error
<b>6413</b>	Error creating scorecard tables for Match Engine
<b>6417</b>	GKB table is empty
<b>6428</b>	Local KB TRULES table open error
<b>6434</b>	Failure to open archive file
<b>6435</b>	Error creating index
<b>6436</b>	Error setting current index
<b>6437</b>	Search KB phase error
<b>6438</b>	Volume serial library phase error
<b>6439</b>	Inter Library phase error
<b>6440</b>	Rules processing phase error
<b>6444</b>	LPA phase error
<b>6448</b>	Error while clearing LMOD count
<b>6449</b>	TDECISION Table is missing FDECRPTION and/or FCATEGORY fields
<b>6450</b>	GKB TPRODUCT record seek error

---

---

<b>6451</b>	LKB TPRODUCT record seek error
<b>6452</b>	TDECISION record edit error
<b>6453</b>	KB TVERSION record access error
<b>6454</b>	KB TPRODUCT record access error
<b>6455</b>	KB TVENDOR record access error
<b>6600</b>	Match Engine tables TDECISION and/or TMIGREPORT are missing
<b>6619</b>	Error opening TPACKAGE table
<b>6620</b>	Repository table initialization failed
<b>6621</b>	Failure opening IQ table
<b>6622</b>	Unable to access GKB TVERSION table
<b>6623</b>	IQ TMODULE table is empty
<b>6624</b>	Predecessor inventory ID key does not exist
<b>6625</b>	Repository is not enabled for Unix System Services
<b>6626</b>	Repository must be enabled for Unix System Services, when the REPLACE option is in effect
<b>6627</b>	SYSPLEX ID mismatch in inventory record
<b>6628</b>	SMFID mismatch in inventory record
<b>6629</b>	Inventory ID key of zero is not valid

---

<b>6630</b>	Error in deleting library record
<b>6632</b>	Error transferring TLIBRARY information from IQ to Repository
<b>6633</b>	Error accessing TINVCTL table
<b>6634</b>	Mismatch found between the TINVCTL record flag and the REPLACE option
<b>6635</b>	Error updating FMODCNT field in TLIBRARY and TPOVLIB tables
<b>6636</b>	Product version key error
<b>6637</b>	Module key error
<b>6640</b>	Error updating FINVID field in TINVREG table
<b>6641</b>	Error updating FINVID field in TINVREG table
<b>6642</b>	Error updating summary tables
<b>6643</b>	Error querying table in FMODID order
<b>6645</b>	Error marking TLIBRARY, TMODULETPOVLIB and TPOVINV records as deleted
<b>6647</b>	Repository type does not match IQ type
<b>6648</b>	When using a Continuous Inventory, an Inventory Name must be specified
<b>6666</b>	Error when accessing the TLIBSYS table
<b>6800</b>	At least one repository failed during initialization
<b>6802</b>	No matching LPAR found in table

---

---

<b>6803</b>	Primary Inventory ID set to 0 for LPAR
<b>6804</b>	Error trying to find FMODID or FLIBID
<b>6805</b>	Inventory ID does not exist
<b>6806</b>	Unable to find or create TLPAR record for LPAR
<b>6807</b>	Error trying to find or create Job or User entry
<b>6808</b>	Error writing MTD record
<b>6809</b>	Error updating summary tables
<b>6810</b>	Error adding TUSELIBRARY record
<b>6811</b>	TLIBRARY update error
<b>6812</b>	Summary table error
<b>6813</b>	Error reading import control record
<b>6814</b>	User initiated stop
<b>7000</b>	At least one table failed initialization
<b>7004</b>	Date order error
<b>7005</b>	TMODULE record seek error
<b>7011</b>	Error inserting record into TMODULE table
<b>7013</b>	TJOBDATA record seek error

---

---

**7014** TJOBDATA record add error

---

**7015** TUSERDATA record seek error

---

**7016** TUSERDATA record add error

---

**7017** TUSEMTD record seek error

---

**7018** TUSEMTD record add error

---

**7019** TUSEMTD record edit error

---

**7020** TUSEMTD record delete error

---

**7021** TPOVINV record seek error

---

**7022** TPERIODS record seek error

---

**7023** TPERIODS record add error

---

**7024** TPERIODS record edit error

---

**7025** TUSEPOVLIB record seek error

---

**7026** TUSEPOVLIB record add error

---

**7027** TUSEPOVLIB record edit error

---

**7028** TUSEPOV record seek error

---

**7029** TUSEPOV record add error

---

**7030** TUSEPOV record edit error

---

---

<b>7034</b>	TUSEMTD critical failure
<b>7035</b>	TUSEMTD error updating record with zero FMTDID
<b>7036</b>	TVERSION record seek error
<b>7037</b>	TUSEPO record seek error
<b>7038</b>	TUSEPO record seek error
<b>7039</b>	TUSEPO record edit error
<b>7040</b>	TUSEPO record delete error
<b>7043</b>	TMODULE record edit error
<b>7044</b>	TUSEPOVLIB record delete error
<b>7045</b>	TUSEPOV record delete error
<b>7046</b>	TPERIODS record delete error
<b>7055</b>	TLPAR record edit error
<b>7058</b>	TPOVLIB record seek error
<b>7060</b>	TLPAR record seek error
<b>7061</b>	Join record seek error
<b>7062</b>	TLIBRARY record edit error
<b>7063</b>	TLIBRARY record seek error

---

<b>7065</b>	Invalid SUMBY value
<b>7066</b>	Date formatting error
<b>7068</b>	PRODUCT_USE delete error
<b>7069</b>	PRODUCT_USE_DETAIL delete error
<b>7201</b>	Inventory to be deleted does not exist in repository
<b>7203</b>	TLIBRARY record delete failure
<b>7204</b>	TPOVINV record delete failure
<b>7205</b>	TPERIODS record delete failure
<b>7206</b>	TLPAR record delete failure
<b>7208</b>	Failure updating Delete Inventory ID record
<b>7209</b>	Failure deleting TINVCTL records of deleted inventory
<b>7210</b>	Error scanning product version
<b>7211</b>	Error reassigning predecessor links in successor InvCTL records
<b>7600</b>	Table initialization failure
<b>7601</b>	Destination repository column size failure
<b>7602</b>	TINVCTL record seek error
<b>7603</b>	TINVCTL record edit error

---

---

<b>7604</b>	TINVCTL record add error
<b>7605</b>	TINVCTL record delete error
<b>7606</b>	TLIBRARY record seek error
<b>7607</b>	TLIBRARY record edit error
<b>7608</b>	TLIBRARY record add error
<b>7609</b>	TLIBRARY record delete error
<b>7610</b>	Transfer product version join seek error
<b>7611</b>	TPOVLIB record seek error
<b>7612</b>	TPOVLIB record edit error
<b>7613</b>	TPOVLIB record add error
<b>7614</b>	TPOVLIB record delete error
<b>7615</b>	TPOVINV record seek error
<b>7616</b>	TPOVINV record edit error
<b>7617</b>	TPOVINV record add error
<b>7618</b>	TPOVINV record delete error
<b>7619</b>	Table TINVPOV failed in initialization
<b>7620</b>	TVERSION record seek error

---

---

**7621** TVERSION record edit error

---

**7622** TVERSION record add error

---

**7623** TVERSION record delete error

---

**7624** Table TVERSION open failed

---

**7625** TPRODUCT record seek error

---

**7626** TPRODUCT record edit error

---

**7627** TPRODUCT record add error

---

**7628** TPRODUCT record delete error

---

**7629** TPRODUCT open error

---

**7630** TVENDOR record seek error

---

**7631** TVENDOR record edit error

---

**7632** TVENDOR record add error

---

**7633** TVENDOR record delete error

---

**7634** TVENDOR open error

---

**7635** TMODULE record seek error

---

**7636** TMODULE record edit error

---

**7637** TMODULE record add error

---

---

**7638** TMODULE record delete error

---

**7639** TREGCLASS record seek error

---

**7640** TREGCLASS record edit error

---

**7641** TREGCLASS record add error

---

**7642** TREGCLASS record delete error

---

**7643** TREGION record seek error

---

**7644** TREGION record edit error

---

**7645** TREGION record add error

---

**7646** TREGION record delete error

---

**7647** TREGLEAF record seek error

---

**7648** TREGLEAF record edit error

---

**7649** TREGLEAF record add error

---

**7650** TREGLEAF record delete error

---

**7651** TINVREG record seek error

---

**7652** TINVREG record edit error

---

**7653** TINVREG record add error

---

**7654** TINVREG record delete error

---

---

**7655** TJOBDATA record seek error

---

**7656** TJOBDATA record edit error

---

**7657** TJOBDATA record add error

---

**7658** TJOBDATA record delete error

---

**7659** TUSERDATA record seek error

---

**7660** TUSERDATA record edit error

---

**7661** TUSERDATA record add error

---

**7662** TUSERDATA record delete error

---

**7663** TLPAR record seek error

---

**7664** TLPAR record edit error

---

**7665** TLPAR record add error

---

**7666** TLPAR record delete error

---

**7667** TUSEMTD record seek error

---

**7668** TUSEMTD record edit error

---

**7669** TUSEMTD record add error

---

**7670** TUSEMTD record delete error

---

**7675** TPERIODS record seek error

---

<b>7676</b>	TPERIODS record edit error
<b>7677</b>	TPERIODS record add error
<b>7678</b>	TPERIODS record delete error
<b>7679</b>	TUSEPOVLIB record seek error
<b>7680</b>	TUSEPOVLIB record edit error
<b>7681</b>	TUSEPOVLIB record add error
<b>7682</b>	TUSEPOVLIB record delete error
<b>7683</b>	TUSEPOVLIB open error
<b>7684</b>	TUSEPOV record seek error
<b>7685</b>	TUSEPOV record edit error
<b>7686</b>	TUSEPOV record add error
<b>7687</b>	TUSEPOV record delete error
<b>7688</b>	TUSEPOV open error
<b>7689</b>	TUSEPO record seek error
<b>7690</b>	IDS_MRGE_TUSEPO_EDIT_ERROR
<b>7691</b>	TUSEPO record add error
<b>7692</b>	TUSEPO record delete error

<b>7693</b>	TUSEPO open error
<b>7698</b>	Source and destination repositories are not the same type
<b>7699</b>	Source and/or Destination Repositories are not the correct category database
<b>7827</b>	Memory error encountered
<b>8100</b>	SMF Scanner error
<b>8200</b>	SCRT unspecified fatal error
<b>8280</b>	Uneven Max Contributor record elements

## HSII - REXX utility messages

These messages are issued by the REXX utility.

### Return codes

**Table 102. Return codes and their meaning**

Return code	Description
0	No errors encountered. All requests processed successfully.
4	Input/Output error in one or more program libraries.
8	Error - Incomplete data. Processing continues. OPEN or other system service error.
12	Syntax error.
16	Unrecoverable error.
20	Disastrous error. No requests processed. SYSPRINT file cannot be used.

### Message suffix codes

**Table 103. Message suffix codes and associated condition codes**

Suffix	Meaning	Raises minimum condition code to:
I	Information message	0

**Table 103. Message suffix codes and associated condition codes (continued)**

Suffix	Meaning	Raises minimum condition code to:
W	Warning message	4
E	Error message	8
S	Severe error message	12
U	Unrecoverable error message	16

**Message texts and explanations**

All numeric completion codes of system services reported in these messages are in hexadecimal unless otherwise stated.

**HSII001I** READ FAILED FOR SYSIN, RC=*rc*

**Explanation:** The HSII001I program could not read commands from the SYSIN DDname. In the message text:

*rc*

return code from EXECIO

**System action:** The program terminates and takes no actions.

**Operator response:** Correct the JCL and provide a SYSIN DD with valid control statements.

**System programmer response:** None.

**Module:** HSII001I

**HSII002I** REQUIRED PARAMETER *prm* IS MISSING FROM SYSIN

**Explanation:** The HSII002I program did not find the required parm in the SYSIN supplied by the user. In the message text:

*prm*

name of the parm that is missing.

**System action:** The program terminates and takes no actions.

**Operator response:** Correct the SYSIN and supply the required parm.

**System programmer response:** None.

**Module:** HSII002I

**HSII003I** THE DEFAULT VALUE "*prm=dft*" IS BEING USED.

**Explanation:** The submitted HSISCUST Job SYSIN did not contain this parameter and the default value will now be used. In the message text:

***prm***

name of the parameter.

***dft***

supplied default.

**System action:** The program continues and uses the default as documented in the message.

**Operator response:** If the default value is to be overridden supply the parameter value in the HSISCUST Job SYSIN stream then resubmit.

**System programmer response:** None.

**Module:** HSIIICUST

---

### **HSII004I** ALLOCATION OF DATASET *dsn* TO *dd* FAILED, RC=*rc*

**Explanation:** The HSIIICUST program could not allocate the dataset to the ddname. In the message text:

***dsn***

name of the dataset that failed allocation.

***dd***

DD name to be allocated.

***rc***

return code from the allocate command.

**System action:** The program terminates and takes no actions.

**Operator response:** Check the return code from the allocate command in the TSO commands manual. Correct the options and try running the program again. The probable option in error is HSIINST.

**System programmer response:** None.

**Module:** HSIIICUST

---

### **HSII005I** *func* FAILED FOR *rsc*, RC=*rc*

**Explanation:** The HSIIICUST program could not perform a required ISPF function because an error occurred during the function execution. In the message text:

***func***

name of ISPF function that failed.

***rsc***

resource that caused the failure.

**rc**

return code from the ISPF function.

**System action:** The program terminates and takes no actions. The program may have written out JCL and parameter members. These members should be treated as suspect as they might contain errors in them due to the nature of this error.

**Operator response:** Check that the options specified do not exceed the field length requirements of the various options. If you cannot resolve this issue, gather appropriate diagnostic materials and contact IBM support.

**System programmer response:** None.

**Module:** HSIICUST

---

**HSII006I** MODEL DATASET SHSISAMP HAS NOT BEEN FOUND.

**Explanation:** The HSIICUST program could not find the SHSISAMP dataset created during installation.

**System action:** The program terminates and takes no actions.

**Operator response:** Check that the HSI option is correctly specified and that the installation target libraries are available to the customization program.

**System programmer response:** None.

**Module:** HSIICUST

---

**HSII007I** CUSTOMIZATION TERMINATES ...

**Explanation:** The HSIICUST program encountered an error during execution.

**System action:** The program terminates and takes no further action.

**Operator response:** Check the previous message which will identify the component causing the problem.

**System programmer response:** None.

**Module:** HSIICUST

---

**HSII008I** *prm* PARAMETER VALUE *pval* IS > *plen* CHARACTERS.

**Explanation:** The HSIICUST program found a parameter value with a length greater than the allowed value for that parm. In the message text:

***prm***

name of HSISCUST parameter that failed.

***pval***

contents of the PARM.

***plen***

length of Parameter value.

**System action:** The program terminates and takes no actions.

**Operator response:** Check the parameter in question and re-submit the HSISCUST JCL after correcting the length error.

**System programmer response:** None.

**Module:** HSIIICUST

---

**HSII009I**

*prm* DATASET *dsn* WAS NOT FOUND ON SYSTEM *system*

**Explanation:** The HSIIICUST program found a parameter value, which requires a Dataset name. This Dataset name could not be found on the system. In the message text:

***prm***

name of HSIIICUST parameter that failed.

***dsn***

dataset name associated with the PARM.

***system***

Operating System name.

**System action:** The program terminates and takes no actions.

**Operator response:** Check the parameter in question and re-submit the HSIIICUST JCL after correcting the DSN error.

**System programmer response:** None.

**Module:** HSIIICUST

---

**HSII010I**

*verb* STATEMENT VERB NOT ONE OF *list*

**Explanation:** During syntax parsing for a statement the verb found does not match any of the valid verbs for the program. In the message text:

***verb***

word that is not a valid verb.

***list***

list of valid verbs.

**System action:** The program terminates and takes no actions.

**Operator response:** Update the statements to the program to correct the verb in error and supply a correct verb.

**System programmer response:** None.

**Module:** HSIKBT

---

**HSII011I**            *word* NOT VALID FOR VERB *verb*

**Explanation:** During syntax parsing for a statement, a word was found that does not match the syntax of the statement for the verb that is being processed. In the message text:

***word***

word that is not valid for the statement syntax for a verb.

***verb***

the verb of the statement that encountered the error.

**System action:** The program terminates and takes no actions.

**Operator response:** Update the statements to the program to correct the statement in error.

**System programmer response:** None.

**Module:** HSIKBT

---

**HSII012I**            PARAMETER *prm* IS NOT A VALID HSISCUST PARAMETER

**Explanation:** An invalid HSISCUST SYSIN parameter has been found. In the message text:

***prm***

parameter that is invalid.

**System action:** The program terminates.

**Operator response:** Remove the invalid parameter from the HSISCUST Job SYSIN then resubmit.

**System programmer response:** None.

**Module:** HSICUST

---

**HSII013I**            PARAMETER *prm* HAS A NULL VALUE

**Explanation:** The submitted HSISCUST Job SYSIN has encountered a parameter with a NULL value. In the message text:

***prm***

name of the parameter that is null.

**System action:** The program terminates.

**Operator response:** Ensure that the HSISCUST parameter has a valid parameter value in the HSISCUST Job SYSIN then resubmit.

**System programmer response:** None.

**Module:** HSIIICUST

---

**HSII014I**           PARAMETER VALUE FOR *prm* HAS UNBALANCED QUOTES, PARAMETER VALUE IS *pval*

**Explanation:** An HSISCUST parameter contains unbalanced quotes. In the message text:

***prm***

name of the parameter with unbalanced quotes.

***pval***

parameter value.

**System action:** The program terminates

**Operator response:** Ensure that the Parameter value is enclosed within single quotation marks then resubmit the HSISCUST Job.

**System programmer response:** None.

**Module:** HSIIICUST

---

**HSII015I**           DATASET *dsn stat*

**Explanation:** The HSIIICUST program identifies the status of the output datasets that it is going to use. In the message text:

***dsn***

name of output dataset.

***stat***

status of the output dataset.

**System action:** The HSIIICUST program continues processing.

**Operator response:** Informational message, no action required.

**System programmer response:** None.

**Module:** HSIIICUST

---

**HSII016I**           UNMATCHED COMMENT DELIMITER IN HSISCUST STATEMENT: *stmt*

**Explanation:** The HSIIICUST program found an error in the comment delimiters passed from the HSISCUST SYSIN stream. In the message text:

***stmt***

statement where the error occurred.

**System action:** The program terminates and takes no actions.

**Operator response:** Correct the HSISCUST SYSIN statements and provide valid comment delimiters, /\* \*/.

**System programmer response:** None.

**Module:** HSIIICUST

---

**HSII017I**            PARAMETER *prm* MUST HAVE THE 1ST CHARACTER AS A VALUE BETWEEN A AND Z

**Explanation:** The HSISCUST Job has encountered a parameter in the SYSIN DD stream where the first character is not alphabetic. This parameter value must start with a value between A and Z. In the message text:

***prm***

name of the parameter that has a non alphabetic first character.

**System action:** The program terminates.

**Operator response:** Ensure that the HSISCUST parameter has a value between A and Z, then resubmit the Job.

**System programmer response:** None.

**Module:** HSIIICUST

---

**HSII018I**            *prm* VALUE *pval* MUST BE WITHIN THE VALID RANGE OF *val1* TO *val2*

**Explanation:** The HSIIICUST program encountered a parameter that was outside the valid range of values allowed. In the message text:

***prm***

name of the parameter in error.

***pval***

value of parameter in error.

***val1***

minimum value of valid range.

***val2***

maximum value of valid range.

**System action:** The program terminates and takes no actions.

**Operator response:** Correct the parameter in error and rerun the HSISCUST Job.

**System programmer response:** None.

**Module:** HSIIICUST

---

**HSII019I**            DBTYPE MUST BE THE FIRST PARM IN THE SYSIN STREAM. CURRENT VALUE IS *prm*

**Explanation:** The HSIIICUST program found an error in the first parameter passed from the HSISCUST SYSIN stream. In the message text:

*prm*

statement where the error occurred.

**System action:** The program terminates and takes no actions.

**Operator response:** Correct the HSISCUST SYSIN statements and ensure that DBTYPE= is the first entry. Comment statements and blank lines may precede the DBTYPE= entry.

**System programmer response:** None.

**Module:** HSIIICUST

---

**HSII020I** TAILORING PARAMETERS:

**Explanation:** HSIIICUST progress message.

**System action:** The program continues.

**Operator response:** This is an informational progress message and no further action is required.

**System programmer response:** None.

**Module:** HSIIICUST

---

**HSII021I** CREATING POST-INSTALLATION DATASETS:

**Explanation:** HSIIICUST progress message.

**System action:** The program continues.

**Operator response:** This is an informational progress message and no further action is required.

**System programmer response:** None.

**Module:** HSIIICUST

---

**HSII022I** APPLYING TAILORING INFORMATION TO POST-INSTALLATION MEMBERS:

**Explanation:** HSIIICUST progress message.

**System action:** The program continues.

**Operator response:** This is an informational progress message and no further action is required.

**System programmer response:** None.

**Module:** HSIIICUST

---

**HSII023I** POST-INSTALLATION CUSTOMIZATION COMPLETE.

**Explanation:** HSIIICUST completion message.

**System action:** The program ends successfully.

**Operator response:** This is an informational progress message and no further action is required.

**System programmer response:** None.

**Module:** HSIIICUST

---

**HSII024I**            PARAMETER *prm* CONTAINS AN EXTRANEOUS VALUE: *xval*

**Explanation:** An HSIIICUST parameter contains an extraneous value. In the message text:

***prm***

name of the parameter with an extraneous value.

***xval***

the extraneous value(s).

**System action:** The program terminates

**Operator response:** Ensure that the Parameter value is correctly defined and that any comments are enclosed within comment delimiters.

**System programmer response:** None.

**Module:** HSIIICUST

---

**HSII025I**            PARAMETER VALUE FOR *prm* MUST BE IN QUOTES, PARAMETER VALUE IS *pval*

**Explanation:** An HSIIICUST parameter value contains no quotes. In the message text:

***prm***

name of the parameter.

***pval***

parameter value.

**System action:** The program terminates

**Operator response:** Ensure that the parameter value is enclosed within single quotation marks then resubmit the HSIIICUST Job.

**System programmer response:** None.

**Module:** HSIIICUST

---

**HSII026I**            PARAMETER *prm* MUST BE A VALUE BETWEEN A-Z OR 0-9

**Explanation:** The HSISCUST Job has encountered a parameter in the SYSIN DD stream where the 1st character is not alphanumeric. This parameter value must be a value between A-Z or 0-9 In the message text:

*prm*

name of the parameter that has a non alphanumeric first character.

**System action:** The program terminates.

**Operator response:** Ensure that the HSISCUST parameter has a value between A-Z or 0-9, then resubmit the Job.

**System programmer response:** None.

**Module:** HSIIICUST

---

**HSII027I** *prm* VALUE *pval* FAILED. VALUE MUST BE Db2, SQLITE OR REMOTE.

**Explanation:** The HSIIICUST program encountered an invalid DBTYPE value. In the message text:

*prm*

name of the parameter in error.

*pval*

value of parameter in error.

**System action:** The program terminates and takes no actions.

**Operator response:** Correct the DBTYPE value and rerun the HSIIICUST Job.

**System programmer response:** None.

**Module:** HSIIICUST

---

**HSII028I** PARAMETERS DB AND DBGKB CANNOT HAVE THE SAME DATABASE NAME: *db*

**Explanation:** The HSIIICUST program found that the values of DB and DBGKB are the same. In the message text:

*db*

duplicate Database name.

**System action:** The program terminates and takes no actions.

**Operator response:** Correct the HSIIICUST SYSIN statements and provide unique values for both DB and DBGKB.

**System programmer response:** None.

**Module:** HSIIICUST

---

**HSII100I** *prm* MISSING FROM CONFIGURATION.

**Explanation:** The utility requires the parameter in the TPARAM/SYSIN stream. In the message text:

***prm***

parameter that is missing.

**System action:** The program terminates and takes no actions.

**Operator response:** Update the parameters in the TPARAM/SYSIN DD to add the missing parameter.

**System programmer response:** None.

**Module:** HSIKBT

---

**HSII107I**

*svc* FROM *rsc* FAILED, RC=*rc*

**Explanation:** An error has occurred executing the service for the resource specified. The service issued the return code mentioned. In the message text:

***svc***

service that failed.

***rsc***

resource that failed.

***rc***

return code from service.

**System action:** The program stops processing statements. No changes have been made.

**Operator response:** Report this error to the System Programmer.

**System programmer response:** For "EXECIO READ" service, this means that the resource specified (ddname) is missing or empty. If you cannot resolve this issue, gather appropriate diagnostic materials and contact IBM support.

**Module:** HSIKBT

---

**HSII108I**

SQL *verb* FAILED, SQLCODE=*sqlcode*

**Explanation:** An error has occurred executing the SQL verb for the table specified. In the message text:

***verb***

SQL verb and table name.

***sqlcode***

SQLCODE from failing statement.

**System action:** The program stops processing statements. The current statement changes to Db2 tables are backed out.

**Operator response:** Report this error to the system programmer.

**System programmer response:** If you cannot resolve this issue, gather appropriate diagnostic materials and contact IBM support.

**Module:** HSIKBT

---

**HSII300I** ERROR WRITING TO *ddn*.

**Explanation:** The XML Export utility has a problem writing the XML file. In the message text:

*ddn*

DDNAME of the file

**System action:** The program terminates.

**Operator response:** Check the return code and any preceding messages.

**System programmer response:** None.

**Module:** HSIKBT

---

**HSII301I** NUMBER OF LINES WRITTEN TO SWKBTXML DD IS *ocnt*.

**Explanation:** Number of lines written to SWKBTXML DD by the XML Export utility. In the message text:

*ocnt*

lines written to SWKBTXML DD.

**System action:** The program continues and takes no actions.

**Operator response:** Informational message, no action required.

**System programmer response:** None.

**Module:** HSIKBT

---

**HSII302I** SQL WARNING FOR *warn*.

**Explanation:** SQL warning was issued from a command. In the message text:

*warn*

SQL warning.

**System action:** The program continues.

**Operator response:** None.

**System programmer response:** None.

**Module:** HSIKBT

---

**HSII303I** SQL ERROR FOR *err*.

**Explanation:** The XML Export Utility has encountered an error. In the message text:

**err**

SQL Error.

**System action:** The program terminates and takes no actions.

**Operator response:** Examine the SQL return code to determine the cause of the error. Inform the system programmer.

**System programmer response:** If you cannot resolve this issue, then gather appropriate diagnostic materials and contact IBM support.

**Module:** HSIKBT

---

### **HSII304I**

*err.*

**Explanation:** The XML Export Utility has encountered a DSNREXX error. In the message text:

**err**

DSNREXX error.

**System action:** The program terminates and takes no actions.

**Operator response:** Examine the preceding error messages to determine the error. Inform the system programmer.

**System programmer response:** If you cannot resolve this issue, gather appropriate diagnostic materials and contact IBM support.

**Module:** HSIKBT

---

### **HSII305I**

INVALID SCHEMA *sch*.

**Explanation:** The XML Export Utility has encountered a problem with an invalid schema. In the message text:

**sch**

schema name

**System action:** The program terminates and takes no actions.

**Operator response:** Ensure that the correct Schema is being used.

**System programmer response:** None.

**Module:** HSIKBT

---

### **HSII999U**

MODULE **HSII**MSG FAILED - MSGID=*msgid* RC=*rc* RS=*rs*

**Explanation:** HSII MSG was called to produce a message text, but the call failed. In the message text:

**msgid**

identifier of the failing message.

**rc**

HSIMSG return code.

**rs**

HSIMSG reason code.

**System action:** Terminates with a condition code of 20.**Operator response:** Inform the system programmer.**System programmer response:** Contact IBM support.**Module:** HSIINQ

## HSIP - Inquisitor for z/OS® messages and codes

These messages are issued by the Inquisitor.

**Return codes****Table 104. Return codes and their meaning**

Return code	Description
0	No errors encountered. All requests processed successfully.
4	Input/Output error in one or more program libraries.
8	Error - Data collection is incomplete. Processing continues. The error is in a system service such as OPEN or DYNALLOC. Data that is collected can be processed normally.
12	Syntax error.
16	Unrecoverable error. No requests processed. SYSIN or HSIPZIP or HSIPOUT File cannot be used, or unsupported Operating System.
20	Disastrous error. No requests processed. SYSPRINT file cannot be used.

**Message suffix codes****Table 105. Message suffix codes and associated condition codes**

Suffix	Meaning	Raises minimum condition code to:
I	Information message	0
W	Warning message	4
E	Error message	8
S	Severe error message	12

**Table 105. Message suffix codes and associated condition codes (continued)**

Suffix	Meaning	Raises minimum condition code to:
U	Unrecoverable error message	16

**Message texts and explanations**

All numeric completion codes of system services reported in these messages are in hexadecimal unless otherwise stated.

**HSIP000U** NO USABLE SYSPRINT FILE

**Explanation:** The OPEN of the SYSPRINT file failed. Note: This message is issued by WTO with ROUTCDE=(2,11). All other messages are written to the SYSPRINT file.

**System action:** Terminates with a condition code of 20.

**Operator response:** Ensure a usable SYSPRINT file is allocated. The program overrides any unacceptable DCB values.

**System programmer response:** None.

**Module:** HSIPINQ

**HSIP001U** CANNOT OPEN SYSIN FILE

**Explanation:** The OPEN of the SYSIN file failed.

**System action:** Terminates with a condition code of 16.

**Operator response:** Ensure a usable SYSIN file is allocated.

**System programmer response:** None.

**Module:** HSIPINQ

**HSIP004S** UNKNOWN VERB "*verb*"

**Explanation:** Parsing detected unrecognized data when looking for a verb. In the message text:  
*verb*

name of the encountered verb.

**System action:** Terminates with a condition code of 12.

**Operator response:** Correct the SYSIN file contents and rerun the program.

**System programmer response:** None.

**Module:** HSIPINQ

---

**HSIP005S** UNKNOWN OPERAND "op"

**Explanation:** Parsing detected unrecognized data when looking for an operand. In the message text:

*op*

name of the encountered operand.

**System action:** Terminates with a condition code of 12.

**Operator response:** Correct the SYSIN file contents and rerun the program.

**System programmer response:** None.

**Module:** HSIPINQ

---

**HSIP006S** UNEXPECTED OPEN PARENTHESIS ENCOUNTERED

**Explanation:** Parsing detected an open parenthesis at an unexpected location.

**System action:** Terminates with a condition code of 12.

**Operator response:** Correct the SYSIN file contents and rerun the program.

**System programmer response:** None.

**Module:** HSIPINQ

---

**HSIP007S** UNEXPECTED CLOSE PARENTHESIS ENCOUNTERED

**Explanation:** Parsing detected a close parenthesis at an unexpected location.

**System action:** Terminates with a condition code of 12.

**Operator response:** Correct the SYSIN file contents and rerun the program.

**System programmer response:** None.

**Module:** HSIPINQ

---

**HSIP008S** EXPECTED OPEN PARENTHESIS MISSING

**Explanation:** Parsing did not detect the expected open parenthesis.

**System action:** Terminates with a condition code of 12.

**Operator response:** Correct the SYSIN file contents and rerun the program.

**System programmer response:** None.

**Module:** HSIPINQ

---

**HSIP009S**            EXPECTED CLOSE PARENTHESIS MISSING

**Explanation:** Parsing did not detect the expected close parenthesis.

**System action:** Terminates with a condition code of 12.

**Operator response:** Correct the SYSIN file contents and rerun the program.

**System programmer response:** None.

**Module:** HSIPINQ

---

**HSIP010U**            OPERATING SYSTEM NOT SUPPORTED - CODE "*code*"

**Explanation:** The value of the byte at CVTDCB was not X'9B'. In the message text:

***code***

hexadecimal value of first byte of CVTDCB.

**System action:** Terminates with a condition code of 16.

**Operator response:** This version of the Inquisitor cannot be run on this Operating System. If necessary, gather appropriate diagnostic materials and contact IBM support.

**System programmer response:** None.

**Module:** HSIPINQ

---

**HSIP011I**            MISSING CLOSE PARENTHESIS ASSUMED

**Explanation:** End-of-file was detected for SYSIN before an expected close parenthesis was detected.

**System action:** The request is accepted and processing continues.

**Operator response:** Correct the SYSIN file contents to avoid this message.

**System programmer response:** None.

**Module:** HSIPINQ

---

**HSIP012S**            MISSING OPERAND SUBPARAMETER FOR *spm*

**Explanation:** A required subparameter of an operand was not specified. In the message text:

***spm***

name of the operand being processed.

**System action:** Terminates with a condition code of 12.

**Operator response:** Correct the SYSIN file contents and rerun the program.

**System programmer response:** None.

**Module:** HSIPINQ

---

### **HSIP013S** E-O-F INSTEAD OF EXPECTED CONTINUATION

**Explanation:** End-of-file was detected for SYSIN instead of an expected record required to continue the current statement being parsed.

**System action:** Terminates with a condition code of 12.

**Operator response:** Correct the SYSIN file contents and rerun the program.

**System programmer response:** None.

**Module:** HSIPINQ

---

### **HSIP014I** COMPLETED REQUEST NUMBER *rno* - PROCESSING STATISTICS ARE:

**Explanation:** Processing of a request has been completed. One or more messages follow containing the statistics for the request. In the message text:

***rno***

sequence number of the request.

**System action:** Processing continues.

**Operator response:** None.

**System programmer response:** None.

**Module:** HSIPINQ

---

### **HSIP015I** VOLUMES=*vol* DATASETS=*ds* BAD-D/S=*dsbad* PROGRAMS=*pgms*

**Explanation:** Processing of a request has been completed. Statistics related to the request are shown. In the message text:

***vol***

count of volumes scanned for this request.

***ds***

count of data sets successfully processed.

***dsbad***

count of data sets which could not be processed.

***pgms***

count of programs processed for this request.

**System action:** Processing continues.

**Operator response:** None.

**System programmer response:** None.

**Module:** HSIPINQ

---

### **HSIP016I** ACCEPTED REQUEST NUMBER *rno*

**Explanation:** Parsing of a request has been completed successfully. The request is stored for subsequent processing. In the message text:

***rno***

sequence number of the request.

**System action:** Processing continues.

**Operator response:** None required.

**System programmer response:** None.

**Module:** HSIPINQ

---

### **HSIP017E** DYNALLOC FAILURE: RC=*rc* ERROR=*err* INFO=*inf* VOLUME=*vol*

**Explanation:** A data set could not be dynamically allocated. See message [HSIP080I on page 318](#) for the name of the dataset that incurred the problem. In the message text:

***rc***

return code of the DYNALLOC macro.

***err***

dynamic allocation return code (DARC).

***inf***

dynamic allocation information code.

***vol***

volume serial number of the data set.

**System action:** Processing of this data set is terminated.

**Operator response:** If necessary, rerun when the file is available for use. Note: The meanings of many DARC values are usually available in Appendix A of the ISPF Tutorial.

**System programmer response:** None.

**Module:** HSIPINQ

---

**HSIP018W** VTOC DYNALLOC FAILURE: RC=*rc* ERROR=*err* INFO=*inf* VOLUME=*vol*

**Explanation:** A VTOC could not be dynamically allocated. In the message text:

*rc*

return code of the DYNALLOC

*err*

dynamic allocation return code (DARC).

*inf*

dynamic allocation information code.

*vol*

volume serial number of the data set.

**System action:** Processing of this volume is terminated.

**Operator response:** If necessary, rerun when the VTOC is available for use to process this volume. Note: The meanings of many DARC values are usually available in Appendix A of the ISPF Tutorial.

**System programmer response:** None.

**Module:** HSIPINQ

---

**HSIP020I** *ocnt* INQUISITOR OUTPUT RECORDS WRITTEN

**Explanation:** Processing has concluded and all data files have been closed. In the message text:

*ocnt*

number of records written.

**System action:** Termination continues.

**Operator response:** None required.

**System programmer response:** None.

**Module:** HSIPINQ

---

**HSIP021S** INVALID OPERAND SUBPARAMETER FOR *spm*

**Explanation:** The specified subparameter of an operand was not valid. In the message text:

*spm*

name of the operand being processed.

**System action:** Terminates with a condition code of 12.

**Operator response:** Correct the SYSIN file contents and rerun the program.

**System programmer response:** None.

**Module:** HSIPINQ

---

**HSIP022W** I/O ERR MEMBER *mbr* IN *dsn*

**Explanation:** An I/O error was encountered while reading the contents of a load module. In the message text:

*mbr*

name of the program being processed.

*dsn*

name of the data set being processed.

**System action:** Processing of this member continues.

**Operator response:** None required.

**System programmer response:** None.

**Module:** HSIPINQ

---

**HSIP023W** ABEND *abend* IN OPEN FOR *dsn*

**Explanation:** An abnormal end occurred while opening a data set. In the message text:

*abend*

hexadecimal system abend and reason

*dsn*

name of the data set being processed.

**System action:** Processing of this data set is terminated.

**Operator response:** None required, but you may wish to exclude the data set from processing, or correct the cause of the abend.

**System programmer response:** None.

**Module:** HSIPINQ

---

**HSIP024S** BAD UCBS CAN RETURN CODE OF HEX *rc*

**Explanation:** An unexpected return code was received from UCBS CAN. In the message text:

*rc*

hexadecimal return code from UCBS CAN

**System action:** Processing of volume scanning for this request is terminated.

**Operator response:** Rerun the program when no dynamic reconfiguration changes are being implemented.

**System programmer response:** None.

**Module:** HSIPINQ

---

**HSIP025U**            CANNOT OPEN HSIPOUT FILE

**Explanation:** The OPEN of the HSIPOUT file failed.

**System action:** Terminates with a condition code of 16.

**Operator response:** Ensure that the allocated HSIPOUT file is usable, or omit the HSIPOUT file in favour of using the HSIPZIP file.

**System programmer response:** None.

**Module:** HSIPINQ

---

**HSIP026E**            I/O ERROR ENCOUNTERED READING VTOC OF VOLUME *vol* ON DEVICE *dev*

**Explanation:** An I/O error was encountered while reading a VTOC. In the message text:

*vol*

volume serial number being processed.

*dev*

device number of the volume.

**System action:** Processing of this track of the VTOC is terminated.

**Operator response:** None required, but you may wish to exclude the volume from processing, or correct the cause of the I/O error.

**System programmer response:** None.

**Module:** HSIPINQ

---

**HSIP028U**            CANNOT OPEN HSIPDMP FILE

**Explanation:** The OPEN of the HSIPDMP file failed after DUMPTTEXT was specified.

**System action:** Terminates with a condition code of 16.

**Operator response:** Ensure a usable HSIPDMP file is allocated, or remove all DUMPTTEXT operand's from the contents of the SYSIN file. The DUMPTTEXT operand should only be specified at the request of IBM support.

**System programmer response:** None.

**Module:** HSIPINQ

---

**HSIP029I** TEXT-DUMPS=*cnt*

**Explanation:** Processing of a request with DUMPTTEXT specified has completed. This message follows [HSIP015I on page 297](#). In the message text:

***cnt***

count of load module text blocks written.

**System action:** Processing continues.

**Operator response:** None required. The DUMPTTEXT operand should only be specified at the request of IBM support.

**System programmer response:** None.

**Module:** HSIPINQ

---

**HSIP030I** "DUMPTTEXT" OPERAND IGNORED FOR "SCANDIR" VERB

**Explanation:** A DUMPTTEXT operand was encountered for a SCANDIR request. That is, the possible dumping of load module text blocks was specified in a request which does not have access to text blocks.

**System action:** The DUMPTTEXT operand is ignored and processing continues.

**Operator response:** Remove the DUMPTTEXT operand to avoid this message. The DUMPTTEXT operand should only be specified at the request of IBM support.

**System programmer response:** None.

**Module:** HSIPINQ

---

**HSIP031I** BAD SELECTION CRITERIA FOR *dsn*

**Explanation:** Processing of a data set was specified but attributes did not match other selection criteria also specified in the request. This message is followed by [HSIP015I on page 297](#) which details the cause. In the message text:

***dsn***

name of the data set being processed.

**System action:** Processing of this data set is terminated.

**Operator response:** If this data set is a program library which should be processed by the Inquisitor then modify or remove the conflicting selection criteria.

**System programmer response:** None.

**Module:** HSIPINQ

---

**HSIP032I**            OBTAIN FAILED RC=*rc* VOLUME *vol*

**Explanation:** The system could not read the VTOC entry for the data set named in the [HSIP033I on page 303](#) message which follows this message. This message is only issued when DSNMSG or ALLMSG is specified in the program parameter. In the message text:

***rc***

hexadecimal return code of the OBTAIN macro.

***vol***

volume serial number being processed.

**System action:** Processing of this data set is terminated.

**Operator response:** Ensure the relevant catalog entry is correct. Ensure the relevant volume is online and available to the system. Ensure there is no I/O error in the relevant volume's VTOC. If necessary, gather appropriate diagnostic materials and contact IBM support.

**System programmer response:** None.

**Module:** HSIPINQ

---

**HSIP033I**            OBTAIN FAILED FOR DATA SET *dsn*

**Explanation:** The system could not read the VTOC entry for the data set on the volume named in the previous [HSIP032I on page 303](#) message. This message is only issued when DSNMSG or ALLMSG is specified in the program parameter. In the message text:

***dsn***

name of the data set being processed.

**System action:** Processing of this data set is terminated.

**Operator response:** Ensure the relevant catalog entry is correct. Ensure the relevant volume is online and available to the system. Ensure there is no I/O error in the relevant volumes VTOC. If necessary, gather appropriate diagnostic materials and contact IBM support.

**System programmer response:** None.

**Module:** HSIPINQ

---

**HSIP034I**            REFER DATE WAS *date* FOR *dsn*

**Explanation:** A load library was opened. The reference date of the data set before the OPEN is reported in this message. This message is only issued when DSNMSG or ALLMSG is specified in the program parameter. In the message text:

***date***

the Julian reference date from the VTOC entry.

***dsn***

name of the data set being processed.

**System action:** Processing of this data set continues.

**Operator response:** None required.

**System programmer response:** None.

**Module:** HSIPINQ

---

**HSIP036E** OPEN ERROR ENCOUNTERED READING VTOC OF VOLUME *vol* ON DEVICE *dev*

**Explanation:** The VTOC of the volume shown could not be opened. In the message text:

***vol***

volume serial number being processed.

***dev***

device number of the volume.

**System action:** Processing of this track of the VTOC is terminated.

**Operator response:** None required, but you may wish to exclude the volume from processing, or correct the cause of the I/O error.

**System programmer response:** None.

**Module:** HSIPINQ

---

**HSIP037E** SECURITY ACCESS DENIED FOR *dsn*

**Explanation:** A RACROUTE macro determined the program had insufficient security access to read the data set. In the message text:

***dsn***

name of the data set being processed.

**System action:** Processing of this data set is terminated.

**Operator response:** Contact Security Administration to obtain sufficient security access to read the data set or exclude the data set from processing.

**System programmer response:** None.

**Module:** HSIPINQ

---

**HSIP038I** BAD SELECTION CRITERIA WAS *dsn*

**Explanation:** Processing of a data set was specified but attributes did not match other selection criteria also specified in the request. This message follows [HSIP0311 on page 302](#) which shows the data set name. In the message text:

*dsn*

cause of the data set processing failure.

**System action:** Processing of this data set is terminated.

**Operator response:** If this data set is a program library which should be processed by the Inquisitor then modify or remove the conflicting selection criteria.

**System programmer response:** None.

**Module:** HSIPINQ

---

### **HSIP039S** ALL POSSIBLE DATA SETS ARE EXCLUDED

**Explanation:** An exclusion mask has been specified which excludes all possible data sets included by a selection mask. Both masks are shown after this message.

**System action:** Terminates with a condition code of 12.

**Operator response:** Modify or remove the conflicting selection criteria.

**System programmer response:** None.

**Module:** HSIPINQ

---

### **HSIP040S** ALL POSSIBLE DASD VOLUMES ARE EXCLUDED

**Explanation:** An exclusion mask has been specified which excludes all possible DASD volumes included by a selection mask. Both masks are shown after this message.

**System action:** Terminates with a condition code of 12.

**Operator response:** Modify or remove the conflicting selection criteria.

**System programmer response:** None.

**Module:** HSIPINQ

---

### **HSIP041S** ALL POSSIBLE PROGRAMS ARE EXCLUDED

**Explanation:** An exclusion mask has been specified which excludes all possible programs included by a selection mask. Both masks are shown after this message.

**System action:** Terminates with a condition code of 12.

**Operator response:** Modify or remove the conflicting selection criteria.

**System programmer response:** None.

**Module:** HSIPINQ

---

**HSIP042S** ALL POSSIBLE MODULES ARE EXCLUDED

**Explanation:** An exclusion mask has been specified which excludes all possible modules included by a selection mask.

**System action:** Terminates with a condition code of 12.

**Operator response:** Modify or remove the conflicting selection criteria. If no CSECT-level records are required then omit both MODULE and XMODULE operands.

**System programmer response:** None.

**Module:** HSIPINQ

---

**HSIP043I** "MODULE"/"CSECT" OPERAND IGNORED FOR "SCANDIR" VERB

**Explanation:** A MODULE operand was encountered for a SCANDIR request. That is, the output of program structure data was requested in a request which does not have access to this data.

**System action:** The MODULE operand is ignored and processing continues.

**Operator response:** Remove the MODULE operand to avoid this message.

**System programmer response:** None.

**Module:** HSIPINQ

---

**HSIP044I** "XMODULE"/"XCSECT" OPERAND IGNORED FOR "SCANDIR" VERB

**Explanation:** An XMODULE operand was encountered for a SCANDIR request. That is, the output of program structure data was implied in a request which does not have access to this data.

**System action:** The XMODULE operand is ignored and processing continues.

**Operator response:** Remove the XMODULE operand to avoid this message.

**System programmer response:** None.

**Module:** HSIPINQ

---

**HSIP045I** THE "XDSNAME" MASK IS NOT A SUBSET OF ANY "DSNAME" MASK

**Explanation:** The mask specified in the XDSNAME operand excludes possible values not included in the DSNAME operand. This message is issued to highlight possible inconsistencies in a request.

**System action:** Processing continues.

**Operator response:** Specify the XDSNAME operand as a further qualification of the DSNAME operand to avoid this message.

**System programmer response:** None.

**Module:** HSIPINQ

---

**HSIP046I** THE "XVOLUME" MASK IS NOT A SUBSET OF ANY "VOLUME" MASK

**Explanation:** The mask specified in the XVOLUME operand excludes possible values not included in the VOLUME operand. This message is issued to highlight possible inconsistencies in a request.

**System action:** Processing continues.

**Operator response:** Specify the XVOLUME operand as a further qualification of the VOLUME operand to avoid this message.

**System programmer response:** None.

**Module:** HSIPINQ

---

**HSIP047I** THE "XPROGRAM" MASK IS NOT A SUBSET OF ANY "PROGRAM" MASK

**Explanation:** The mask specified in the XPROGRAM operand excludes possible values not included in the PROGRAM operand. This message is issued to highlight possible inconsistencies in a request.

**System action:** Processing continues.

**Operator response:** Specify the XPROGRAM operand as a further qualification of the PROGRAM operand to avoid this message.

**System programmer response:** None.

**Module:** HSIPINQ

---

**HSIP048I** THE "XMODULE" MASK IS NOT A SUBSET OF ANY "MODULE" MASK

**Explanation:** The mask specified in the XMODULE operand excludes possible values not included in the MODULE operand. This message is issued to highlight possible inconsistencies in a request.

**System action:** Processing continues.

**Operator response:** Specify the XMODULE operand as a further qualification of the MODULE operand to avoid this message.

**System programmer response:** None.

**Module:** HSIPINQ

**HSIP049I** THE "XSTOGRROUP" MASK IS NOT A SUBSET OF ANY "STOGRROUP" MASK

**Explanation:** The mask specified in the XSTOGRROUP operand excludes possible values not included in the STOGRROUP operand. This message is issued to highlight possible inconsistencies in a request.

**System action:** Processing continues.

**Operator response:** Specify the XSTOGRROUP operand as a further qualification of the STOGRROUP operand to avoid this message.

**System programmer response:** None.

**Module:** HSIPINQ

---

**HSIP050I** MODULES=*cnt*

**Explanation:** Processing of a request with MODULE specified has completed. This message follows [HSIP015I on page 297](#). In the message text:

*cnt*

count of CSECTs processed in this request.

**System action:** Processing continues.

**Operator response:** None required.

**System programmer response:** None.

**Module:** HSIPINQ

---

**HSIP051I** \*\*\*\*\* PARSE ONLY REQUEST PROCESSED - NO ACTION TAKEN \*\*\*\*\*

**Explanation:** Processing of a SCANCMD request has completed.

**System action:** Processing continues.

**Operator response:** None required.

**System programmer response:** None.

**Module:** HSIPINQ

---

**HSIP052U** MISSING HSIPOUT AND HSIPZIP FILES

**Explanation:** Neither an HSIPOUT nor an HSIPZIP file is allocated. At least one output file is required.

**System action:** Terminates with a condition code of 16.

**Operator response:** Specify an output file and rerun the job.

**System programmer response:** None.

**Module:** HSIPINQ

---

**HSIP053U**            COMPRESSION SUBROUTINE ERROR

**Explanation:** While processing the HSIPZIP file the compression subroutine encountered an error. The error message from the compression subroutine immediately follows this message.

**System action:** Terminates with a condition code of 16.

**Operator response:** Correct the error described in the message from the compression subroutine. If necessary, gather appropriate diagnostic materials and contact IBM support.

**System programmer response:** None.

**Module:** HSIPINQ

---

**HSIP054I**            "FULLIDR" OPERAND IGNORED FOR "SCANDIR" VERB

**Explanation:** A FULLIDR operand was encountered for a SCANDIR request. That is, the processing of load module member contents was specified in a request which does not have access to this data.

**System action:** The FULLIDR operand is ignored and processing continues.

**Operator response:** Remove the FULLIDR operand to avoid this message.

**System programmer response:** None.

**Module:** HSIPINQ

---

**HSIP056I**            *date time* COMMENCING SCAN OF VOLUME *vol* ON UNIT *unit*

**Explanation:** A request without the CATALOG keyword began processing a DASD volume. This message provides feedback on the progress of long-running Inquisitor requests. In the message text:

***date***

date of message.

***time***

time of message.

***vol***

serial number of volume.

***unit***

device number of volume.

**System action:** Processing continues.

**Operator response:** None required.

**System programmer response:** None.

**Module:** HSIPINQ

---

**HSIP057E** ABEND *abend* PROCESSING VTOC OF VOLUME *vol* ON UNIT *unit*

**Explanation:** A request without the CATALOG keyword attempted to process a DASD volume VTOC and the OPEN or CLOSE abended. The volume may not not usable. In the message text:

***abend***

hexadecimal system abend and reason codes.

***vol***

serial number of volume.

***unit***

device number of volume being processed.

**System action:** Processing of this volume is terminated.

**Operator response:** Vary the volume offline, and/or reformat the volume. Institute any appropriate volume recovery procedures.

**System programmer response:** None.

**Module:** HSIPINQ

---

**HSIP058S** DUPLICATE OPERAND ENCOUNTERED: *op*

**Explanation:** An input request was found to have the indicated operand specified more than once. In the message text:

***op***

name of the duplicate operand

**System action:** Terminates with a condition code of 12.

**Operator response:** Correct the SYSIN file contents and rerun the program.

**System programmer response:** None.

**Module:** HSIPINQ

---

**HSIP059W** BINDER FAILURE FOR MEMBER *mbr* RC=*rc* RS=*rs*

**Explanation:** The Binder could not successfully process a member of a PDSE. In the message text:

***mbr***

name of the member being processed.

**rc**

hexadecimal Binder FDA API return code.

**rs**

hexadecimal Binder FDA API reason code.

**System action:** Terminates data collection for this member, writes out data already collected and continues processing the next member.

**Operator response:** None required.

**System programmer response:** The Binder Fast Data Access API return and reason codes provide more detailed indication of the cause.

**Module:** HSIPINQ

---

### **HSIP060S**      SYMBOL SUBSTITUTION FAILURE - ASASYMBP RC=*rc*

**Explanation:** The system symbol substitution routine could not successfully perform symbol substitution. Data before and after substitution is shown in the SYSPRINT file. In the message text:

**rc**

hexadecimal return code.

**System action:** Terminates with a condition code of 12.

**Operator response:** Correct or remove the symbols in control statement input.

**System programmer response:** None.

**Module:** HSIPINQ

---

### **HSIP061I**      *pgm* NON-REEDITABLE IN *dsn*

**Explanation:** A program object in a PDSE was encountered which cannot be processed by the Program Binder. The program was bound with the NE or OVLY attribute. This message is only issued when PGMMMSG or ALLMSG is specified in the program parameter. This message is not issues for DLL-enable program objects. In the message text:

***pgm***

name of program which cannot be processed.

***dsn***

name of the data set being processed.

**System action:** Further data collection for this member is terminated.

**Operator response:** None required.

**System programmer response:** None.

**Module:** HSIPINQ

---

**HSIP062S** THE CATALOG REQUEST NEEDS EXACTLY ONE DSNAME MASK

**Explanation:** A request with the CATALOG operand either omitted the DSNAME operand or specified more than one DSNAME mask.

**System action:** Terminates with a condition code of 12.

**Operator response:** Correct the SYSIN file contents and rerun the program. To process multiple data set name masks via the CATALOG specify a separate Inquisitor request for each mask. There is no programmed limit to the number of requests which can be processed in a single Inquisitor run.

**System programmer response:** None.

**Module:** HSIPINQ

---

**HSIP063S** ALL POSSIBLE STORAGE GROUPS ARE EXCLUDED

**Explanation:** An exclusion mask has been specified which excludes all possible storage groups included by the selection mask. Both masks are shown after this message.

**System action:** Terminates with a condition code of 12.

**Operator response:** Modify or remove the conflicting selection criteria.

**System programmer response:** None.

**Module:** HSIPINQ

---

**HSIP064W** ABEND *abend* FOR *mbr* IN *dsn*

**Explanation:** A subtask processing a program object from a PDSE has abended. The abend probably occurred in the Program Binder API. In the message text:

***abend***

hexadecimal system abend code.

***mbr***

name of the member being processed.

***dsn***

name of the data set being processed.

**System action:** Data collected for this member so far is retained. Other Data Management abends may follow, especially in CLOSE processing, which are unrecoverable and may abend the main Inquisitor task.

**Operator response:** Exclude the programs causing the failure and rerun the Job.

**System programmer response:** None.

**Module:** HSIPINQ

---

**HSIP065S**      MCDS FILE FAILED VERIFICAION

**Explanation:** The MCDS data definition (DD) was found to be unusable by the Inquisitor. One or more of the following is true: 1) The MCDS file could not be opened. Message [HSIP066E on page 313](#) follows. 2) The MCDS file is not a VSAM key-sequenced data set (KSDS). 3) The KSDS relative key position (RKP) is not zero (0). 4) The KSDS key length is not forty-four (44).

**System action:** Terminates with a condition code of 12.

**Operator response:** Either ensure that the Inquisitor has read access to DFHSM's MCDS, or change the Inquisitor request(s) so that the MCDS is not required. MCDS access is required if either or both of the REMIGRATE and NOML2 keywords are specified.

**System programmer response:** None.

**Module:** HSIPINQ

---

**HSIP066E**      MCDS OPEN ERROR - RC=*rc* RS=*rs*

**Explanation:** The OPEN of the MCDS data definition (DD) was not successful. In the message text:

*rc*

VSAM OPEN hexadecimal return code.

*rs*

VSAM OPEN hexadecimal reason code.

**System action:** Issues message [HSIP065S on page 313](#) and terminates with a condition code of 12.

**Operator response:** Either ensure that the Inquisitor has read access to DFHSM's MCDS, or modify the Inquisitor request(s) so that the MCDS is not required. MCDS access is required if either or both of the REMIGRATE and NOML2 keywords are specified.

**System programmer response:** None.

**Module:** HSIPINQ

---

**HSIP067E**      MCDS READ RC=*rc* RS=*rs* FOR *dsn*

**Explanation:** The MCDS record of a data set cataloged on volume MIGRAT could not be read. Either the record is missing or there was an I/O error. In the message text:

*rc*

VSAM GET hexadecimal return code.

*rs*

VSAM GET hexadecimal reason code.

*dsn*

name of data set cataloged on volume MIGRAT.

**System action:** Processing of this data set is terminated.

**Operator response:** If the data set is not really migrated then correct the catalog entry. If the MCDS is corrupt then begin recovery procedures.

**System programmer response:** None.

**Module:** HSIPINQ

---

**HSIP068W** CATALOG RC=*rc* RS=*rs,modid cat*

**Explanation:** The Catalog Search Interface returned an entry which is flagged as being in error by Catalog Management. In the message text:

***rc***

Catalog Management decimal return code.

***rs***

Catalog Management decimal reason code.

***modid***

Catalog Management module identifier.

***cat***

name of catalog entry in error.

**System action:** Processing of this data set is terminated.

**Operator response:** Correct the catalog entry. Refer to the System Messages manual for message IDC3009I to find out the meaning of the Catalog Management error codes.

**System programmer response:** None.

**Module:** HSIPINQ

---

**HSIP069U** PROGRAM IS NOT APF AUTHORIZED

**Explanation:** The Inquisitor has determined that it is not running in an APF authorized environment, and PARM=NOAPF was not specified.

**System action:** Terminates with a condition code of 20.

**Operator response:** Ensure that the HSIPINQ program is run in an APF authorized environment, or specify PARM=NOAPF in the JCL.

**System programmer response:** None.

**Module:** HSIPINQ

---

**HSIP070E** BAD BLKSIZE AFTER OPEN FOR *dsn*

**Explanation:** A BPAM DCB was opened for the named PDS, but despite the VTOC entry indicating a suitable blocksize, the blocksize in the DCB after the OPEN was not positive. In the message text:

***dsn***

name of the data set being processed.

**System action:** Processing of member contents for this data set is terminated to avoid an S002-30 abend.

**Operator response:** The PDS is probably corrupt and should be deleted. Recreate it from a backup if appropriate.

**System programmer response:** None.

**Module:** HSIPINQ

---

### **HSIP071W**           IGNORING INVALID DSNAME IN *dsn*

**Explanation:** The Catalog Search Interface (CSI) returned a data set name with invalid characters. Although VTOC entries can contain keys that are not valid data set names, such entries cannot be cataloged. Therefore the entry returned from the CSI does not represent an actual data set. In the message text:

***dsn***

name of the catalog being processed.

**System action:** The returned catalog entry is discarded.

**Operator response:** Ensure that the named catalog is not corrupt and contains no invalid entries.

**System programmer response:** None.

**Module:** HSIPINQ

---

### **HSIP072I**           BYPASS PROCESSING DATA SET *dsn* DUE TO *patn* NAME PATTERN MATCH

**Explanation:** The name of the data set indicated that it does not contain programs which would normally be executed, and therefore the Inquisitor skipped processing it. The matching name pattern will be one of DLIB (distribution library), RELFILE (SMP/E relative file), SMPLTS (SMP/E Load Temporary Store library) or IMS LIBRARY. This message is only issued when DSNMSG or ALLMSG is specified in the program parameter. In the message text:

***dsn***

name of the data set being bypassed.

***patn***

matching data set type name pattern.

**System action:** The data set is not opened, and no data from it is collected.

**Operator response:** None required, but if the data set must be processed then specify its name in an inclusion mask without any generic masking characters, either by adding this mask to the existing request, or by adding an additional request to the same Inquisitor run.

**System programmer response:** None.

**Module:** HSIPINQ

---

**HSIP073I** NO DATA WAS EXTRACTED FROM *dsn*

**Explanation:** The data set contained no members eligible for selection. This message is only issued when DSNMSG or ALLMSG is specified in the program parameter. In the message text:

***dsn***

name of the processed data set.

**System action:** The data set was opened, but no data from it is collected.

**Operator response:** None required.

**System programmer response:** None.

**Module:** HSIPINQ

---

**HSIP074S** ABRIN OR ABRPRINT FILES NOT ALLOCATED

**Explanation:** A request had ABRMIG and/or ABRARC specified but at least one of the required ABRIN and ABRPRINT files was not defined in the JCL.

**System action:** Terminates with a condition code of 12.

**Operator response:** Ensure the required files are pre-allocated for the Inquisitor.

**System programmer response:** None.

**Module:** HSIPINQ

---

**HSIP075W** FDRABR ABEND *abend* CHECKING *dsn*

**Explanation:** An abend occurred during ABR processing while checking a data set which may have been archived. In the message text:

***abend***

hexadecimal system abend code.

***dsn***

name of the data set being processed.

**System action:** Processing of this data set is terminated.

**Operator response:** Ensure the catalog entry for the data set is correct.

**System programmer response:** None.

**Module:** HSIPINQ

---

**HSIP076E**      BAD LOAD *abend-rs: mbr dsn*

**Explanation:** The Inquisitor attempted to load a product tag data module from the named data set, but LOAD issued the displayed abend code. In the message text:

***abend***

abend code returned by LOAD.

***rs***

abend reason code returned by LOAD.

***mbr***

name of the member containing the tag data.

***dsn***

name of the data set containing the tag data module.

**System action:** Processing continues with the next member in the data set.

**Operator response:** Verify that the named data set contains no unusable modules. If necessary, delete any modules that are of no further use.

**System programmer response:** None.

**Module:** HSIPINQ

---

**HSIP077W**      ISITMGD RC=*rc* RS=*rs* FOR *dsn*

**Explanation:** The Inquisitor executed an ISITMGD macro for the named data set, but ISITMGD issued a non-zero return code. In the message text:

***rc***

decimal return code issued by ISITMGD.

***rs***

hexadecimal reason code issued by ISITMGD.

***dsn***

name of the data set being processed.

**System action:** Processing continues with the next data set.

**Operator response:** Consult the applicable DFSMS Macro Instructions for Data Sets manual to determine the meaning of the ISITMGD return and reason codes. Ensure that the named data set is a valid and accessible partitioned data set. If necessary, gather appropriate diagnostic materials and contact IBM support.

**System programmer response:** None.

**Module:** HSIPINQ

---

**HSIP078W** DESERV RC=*rc* RS=*rs* FOR *dsn*

**Explanation:** The Inquisitor executed a DESERV FUNC=GET\_ALL macro for the named data set, but DESERV issued a non-zero return code. In the message text:

***rc***

decimal return code issued by DESERV.

***rs***

decimal reason code issued by DESERV.

***dsn***

name of the data set being processed.

**System action:** Processing continues with the next data set.

**Operator response:** Consult the applicable DFSMS Macro Instructions for Data Sets manual to determine the meaning of the DESERV return and reason codes. Ensure that the named data set is a valid and accessible partitioned data set. If necessary, gather appropriate diagnostic materials and contact IBM support.

**System programmer response:** None.

**Module:** HSIPINQ

---

**HSIP080I** DYNALLOC FAILURE: DSN=*dsn*

**Explanation:** A data set could not be dynamically allocated. In the message text:

***dsn***

name of the data set being processed.

**System action:** Depends upon other messages associated with this message.

**Operator response:** None required.

**System programmer response:** None.

**Module:** HSIPINQ

---

**HSIP081S** ALL POSSIBLE DEVICE NUMBERS ARE EXCLUDED

**Explanation:** An exclusion mask has been specified which excludes all possible device numbers included by a selection mask. Both masks are shown after this message.

**System action:** Terminates with a condition code of 12.

**Operator response:** Modify or remove the conflicting selection criteria.

**System programmer response:** None.

**Module:** HSIPINQ

---

**HSIP082I** THE "XDEVICE" MASK IS NOT A SUBSET OF ANY "DEVICE" MASK

**Explanation:** The mask specified in the XDEVICE operand excludes possible values not included in the DEVICE operand. This message is issued to highlight possible inconsistencies in a request.

**System action:** Processing continues.

**Operator response:** Specify the XDEVICE operand as a further qualification of the DEVICE operand to avoid this message.

**System programmer response:** None.

**Module:** HSIPINQ

---

**HSIP083E** RENAME FAILED FOR DATA SET *dsn*

**Explanation:** The rename operation to add one or more extra low-level qualifiers to a data set name as specified by the LLQ program parameter setting did not succeed. The named data set is allocated to either the HSIPZIP or HSIPOUT file. This message is preceded by either an associated explanatory message, or by messages from IDCAMS detailing the results of the rename attempt. In the message text:

***dsn***

name of the HSIPZIP or HSIPOUT data set.

**System action:** The output data set retains its original name.

**Operator response:** Ensure that the specified LLQ string length does not exceed 44 bytes, that any symbols used are valid for this system, and that resultant data set names are not longer than 44 bytes. Examine associated messages to determine the reason for the rename failure.

**System programmer response:** None.

**Module:** HSIPINQ

---

**HSIP084I** ABEND *abend* OPENING DSN *dsn*

**Explanation:** An abnormal end occurred while opening a data set. In the message text:

***abend***

hexadecimal system abend and reason

***dsn***

name of the data set being processed.

**System action:** Processing of this data set is terminated.

**Operator response:** None required, but you may wish to correct the cause of the abend.

**System programmer response:** None.

**Module:** HSIPINQ

---

**HSIP085I** ABEND *abend* CLOSING DSN *dsn*

**Explanation:** An abnormal end occurred while closing a data set. In the message text:

***abend***

hexadecimal system abend and reason

***dsn***

name of the data set being processed.

**System action:** Processing of this data set is terminated.

**Operator response:** None required, but you may wish to correct the cause of the abend.

**System programmer response:** None.

**Module:** HSIPINQ

---

**HSIP086S** NO PROGRAMS OR TAG DATA FOUND - NO DATA FOR IMPORT WAS PRODUCED

**Explanation:** All scanning operations failed to find any executable programs or program tag data, so no data suitable for subsequent processing was created.

**System action:** Terminates with a condition code of 12.

**Operator response:** Correct any selection criteria errors and rerun the job.

**System programmer response:** None.

**Module:** HSIPINQ

---

**HSIP087I** SKIP INACCESSIBLE DATA SET *dsn*

**Explanation:** The named data set was encountered on an SMS-managed volume, but no matching catalog entry could be located, which means that the data set cannot be successfully allocated by any job. In the message text:

***dsn***

name of the data set being skipped.

**System action:** The data set is bypassed and processing continues.

**Operator response:** None required, but you may wish to either catalog the data set to make it accessible, or delete it to reclaim the disk space.

**System programmer response:** None.

**Module:** HSIPINQ

---

**HSIP088I**            DEVICES=*vol* CU-GROUPS=*ds* USED-CHPIDS=*dsbad*

**Explanation:** Processing of a SCANDEV request has been completed. Counts of online I/O devices, device groups and used channel paths are shown. A group of devices with the same device type, control unit, and CHPID connectivity generates one CU record. A CP record is generated for each online CHPID connected to at least one online I/O device. In the message text:

***vol***

count of online I/O devices discovered.

***ds***

count of CU records written.

***dsbad***

count of CP records written.

**System action:** Processing continues.

**Operator response:** None.

**System programmer response:** None.

**Module:** HSIPINQ

---

**HSIP089E**            INSUFFICIENT AUTHORIZATION TO PROCESS "SCANDEV" REQUEST

**Explanation:** To process a SCANDEV request either the Inquisitor must be APF authorized or the user must have UPDATE access to the IOSCDR entity in the FACILITY security class.

**System action:** Processing continues with the next request.

**Operator response:** Get the appropriate authorization, or omit the SCANDEV request.

**System programmer response:** None.

**Module:** HSIPINQ

---

**HSIP090I**            EXCESSIVE DESERV DELAY FOR *dsn*

**Explanation:** This message is issued when a DESERV macro has not returned control to the Inquisitor after 15 minutes. This might indicate that the data set being processed is corrupt and unusable. In the message text:

***dsn***

name of the data set being scanned.

**System action:** Processing continues, possibly without making any further progress.

**Operator response:** If the scan does not progress, and the delay is not caused by contention with other work, cancel the job. Either delete the data set, or add an exclusion to the Inquisitor control statement before rerunning the job.

**System programmer response:** None.

**Module:** HSIPINQ

---

**HSIP0911** IGNORING OLD TAG MEMBER *mem* IN DATA SET=*dsn*

**Explanation:** This message is issued when a tag member made by the defunct Tagger program HSITAGP is encountered. The Inquisitor will not collect any information from or about this member. In the message text:

***mem***

name of the found tag member.

**Explanation:** In the message text:

***dsn***

name of the data set being scanned.

**System action:** Processing continues.

**Operator response:** The tag member can be safely deleted. Local tagging functions are now available in the Analyzer which can directly update the data base.

---

**HSIP0921** ANOTHER JOB HOLDS *dsn =time / dsn*

**Explanation:** This message is issued when a library to be scanned is found to be exclusively allocated to another job, and therefore cannot be scanned. In the message text:

***time***

time of message.

***dsn***

name of the unavailable data set.

**System action:** Processing continues. If the data set does not become available before the processing of the request completes, an error or warning condition will be raised. The default error condition can be reduced to a warning condition by specifying the INUSEWARN keyword in the request statement.

**Operator response:** If necessary, and if message [HSIP0931 on page 322](#) is not issued for this data set, rerun the scan when the data set is available.

---

**HSIP0931** RETRY SUCCESS FOR *vol / dsn =vol / dsn*

**Explanation:** This message is issued when a library to be scanned was previously found to be exclusively allocated to another job, but has now become available and has been processed. In the message text:

***vol***

serial number of volume.

***dsn***

name of the unavailable data set.

**System action:** Processing continues.

**Operator response:** None.

---

**HSIP094W**      RETRY FAILURE FOR vol / dsn =vol / dsn

**Explanation:** This message is issued when a library to be scanned was previously found to be exclusively allocated to another job, and the data set retried. INUSEWARN was specified on the request. In the message text:

**vol**

serial number of volume.

**dns**

name of the unavailable data set.

**System action:** Processing continues.

**Operator response:** If necessary, rerun the scan when the data set is available.

---

**HSIP095E**      RETRY FAILURE FOR vol / dsn =vol / dsn

**Explanation:** This message is issued when a library to be scanned was previously found to be exclusively allocated to another job, and the data set remains unavailable when the allocation was retried. INUSEWARN was not specified on the request. In the message text:

**vol**

serial number of volume.

**dns**

name of the unavailable data set.

**System action:** Processing continues.

**Operator response:** If necessary, rerun the scan when the data set is available.

---

**HSIP097E**      CATALOG SEARCH INTERFACE ERROR RC=*csirc*

**Explanation:** A request with the CATALOG keyword was specified, and the Catalog Search Interface encountered an error. In the message text:

**csirc**

return code from the Catalog Search Interface.

**System action:** Processing catalog entries for the request is terminated.

**Operator response:** Correct any related catalog errors.

**System programmer response:** None.

**Module:** HSIPINQ

**HSIP098E** CATALOG SEARCH INTERFACE ERROR RC=*csirc* CATALOG RC=*rc* CATALOG RS=*rs*

**Explanation:** A request with the CATALOG keyword was specified, and the Catalog Search Interface encountered an error. In the message text:

***csirc***

return code from the Catalog Search Interface.

***rc***

return code from Catalog Management.

***rs***

reason code from Catalog Management.

**System action:** Processing catalog entries for the request is terminated.

**Operator response:** Correct any related catalog errors.

**System programmer response:** None.

**Module:** HSIPINQ

---

**HSIP099E** CATALOG SEARCH INTERFACE ERROR RC=*csirc* CATALOG RC=*rc* CATALOG RS=*rs*

**Explanation:** A request with the CATALOG keyword was specified, and the Catalog Search Interface encountered an error. In the message text:

***csirc***

return code from the Catalog Search Interface.

***rc***

return code from Catalog Management.

***rs***

reason code from Catalog Management.

***modid***

module identifier.

**System action:** Processing catalog entries for the request is terminated.

**Operator response:** Correct any related catalog errors.

**System programmer response:** None.

**Module:** HSIPINQ

---

**HSIP100I** PROGRAM HSIPVMAP COMPLETED WITH RC=*rc*

**Explanation:** The HSIPVMAP program was invoked to process the optional HSIDAMAP file, and HSIPVMAP issued the return code shown. A return code of zero indicates success. A return code of 8 indicates that the HSIDAMAP DD was allocated, but a problem was encountered trying to process it. In the message text:

**rc**

decimal return code from HSIPVMAP.

**System action:** Processing continues.

**Operator response:** If necessary, investigate any I/O errors associated with the data set allocated to HSIDAMAP. Reconcile the intended mapping(s) with any **HSIP101I** messages that immediately follow. If necessary, correct the assignments and rerun the job.

**System programmer response:** None.

**Module:** HSIPINQ

---

### **HSIP101I**            VOLUMES MATCHING "*v-mask*" WILL BE MAPPED TO "*v-name*"

**Explanation:** The HSIPVMAP program has extracted the displayed logical volume mapping from the HSIDAMAP file. In the message text:

***v-mask***

volume serial selection mask.

***v-name***

assigned logical volume name.

**System action:** Processing continues.

**Operator response:** Verify that the displayed logical volume mapping is as intended. Note that while the Usage Monitor also calls program HSIPVMAP, it does not externalize the results, so trial executions of the HSIPINQ program should be used to test new logical volume mapping assignments before the resulting data is imported into the data base.

**System programmer response:** None.

**Module:** HSIPINQ

---

### **HSIP102U**            DSPSERV CREATE RC=*rc* RS=*rs*

**Explanation:** The Inquisitor executed a DSPSERV CREATE macro to acquire storage to hold collected data, but DSPSERV issued a non-zero return code. In the message text:

**rc**

hexadecimal DSPSERV return code.

**rs**

hexadecimal DSPSERV reason code.

**System action:** Program HSIPINQ abends with user abend code 29 and with the reason code returned by DSPSERV.

**Operator response:** Consult the applicable MVS Programming: Assembler Services Reference manual to determine the meaning of the DSPSERV return and reason codes. Ensure that the job is permitted to acquire numerous data spaces and gigabytes of data space storage.

**System programmer response:** Inspect and, if necessary, alter the DSLIMITNUM and DSLIMITSIZE settings in the SMFLIMxx PARMLIB member that are applied to this job.

**Module:** HSIPINQ

---

### **HSIP103I**            *type* QUEUE MAXIMUM=*count*

**Explanation:** This message is issued when volume-scanning subtasks queue collected data about items such as data sets and programs for processing by the main task. The maximum queue length for each item type is reported. In the message text:

***type***

item type - refer to message **HSIP104I** for possible values.

***count***

maximum queue length.

**System action:** Processing continues.

**Operator response:** None.

**System programmer response:** None.

**Module:** HSIPINQ

---

### **HSIP104I**            *type* DATA SPACE FREE STORAGE ADDRESS IS *addr*

**Explanation:** This message is issued when volume-scanning subtasks use data space storage to queue collected data for processing by the main task. The start address of unused virtual storage in the relevant data space is reported. Pages above this address were not referenced. This message indicates how much data space storage was used by the request. The used storage is also reported as a percentage of the total data space size to provide capacity feedback. In the message text:

***type***

item type. The following data categories might be reported:

- DATASET - contains details of data sets selected for scanning.
- PROGRAM - contains details of programs scanned by subtasks.
- PGMTEXT - contains eyecatchers and character strings from programs scanned by subtasks.
- SECTION - contains details of control sections and LE compile units extracted from programs scanned by subtasks. The data space to hold this item type is only created for SCANPGM FULLIDR requests.

***addr***

8-digit hexadecimal virtual storage address followed by a percentage in parentheses.

**System action:** Processing continues.

**Operator response:** None.

**System programmer response:** None.

**Module:** HSIPINQ

---

### **HSIP105I**            USED DATA SPACE PAGES:*size*

**Explanation:** This message is issued when volume-scanning subtasks use data space storage to queue collected data for processing by the main task. It reports the maximum amount of virtual storage across all data spaces created by the main task for this request that needed to be backed in central and/or auxiliary storage by the system. This storage quantity is also expressed as a percentage to indicate how much of the data space storage that SMF may report as being allocated was actually used. The small data space that may be created by each volume-scanning subtask is not included in these numbers. In the message text:

***size***

virtual storage size, followed by a percentage in parentheses.

**System action:** Processing continues.

**Operator response:** None.

**System programmer response:** None.

**Module:** HSIPINQ

---

### **HSIP106I**            *bytes* COMPRESSED DATA BYTES WRITTEN TO *ddname*

**Explanation:** This message is issued after closing the named output DD which contains compressed (zipped) data. The reported compressed data byte count matches the count contained in the zip file headers, so the count does not include the size of the zip headers. The reported DD name will be HSIPZIP unless HSIPINQ was invoked by another program which supplied a DD override parameter. In the message text:

***bytes***

byte count.

***ddname***

output DD name.

**System action:** Processing continues.

**Operator response:** None.

**System programmer response:** None.

**Module:** HSIPINQ

---

### **HSIP107I**            NUMBER OF CONCURRENT DATA SPACES LIMIT IS *limit*

**Explanation:** This message is issued when a relatively low concurrent data space count limit is detected. Ensure that active SMFLIMxx PARMLIB settings do not unduly limit storage access for the job. The Inquisitor

uses data space storage to reduce the dependency on large region size availability, and depending on the actual request, may allocate up to MAXTASKS+4 data spaces. In the message text:

***limit***

maximum allowed data space count.

**System action:** Processing continues.

**Operator response:** None.

**System programmer response:** None.

**Module:** HSIPINQ

---

**HSIP108I** DATA SPACE STORAGE LIMIT IS *limit* MB

**Explanation:** This message is issued when a relatively low data space storage limit is detected. Ensure that active SMFLIMxx PARMLIB settings do not unduly limit storage access for the job. The Inquisitor uses data space storage to reduce the dependency on large region size availability, and depending on the actual request, may allocate up to four 2 GB and MAXTASKS 16648 KB data spaces. In the message text:

***limit***

maximum allowed data megabyte count.

**System action:** Processing continues.

**Operator response:** None.

**System programmer response:** None.

**Module:** HSIPINQ

---

**HSIP999U** MODULE HSIPMSG FAILED - MSGID=*msgid* RC=*rc* RS=*rs*

**Explanation:** HSIMSG was called to produce a message text, but the call failed. In the message text:

***msgid***

identifier of the failing message.

***rc***

HSIMSG return code.

***rs***

HSIMSG reason code.

**System action:** Terminates with a condition code of 20.

**Operator response:** Inform the system programmer.

**System programmer response:** Contact IBM Support.

**Module:** HSIPINQ

## HSIT - Product tagging messages

These messages are issued by the Product Tagger.

### Return codes

**Table 106. Return codes and their meaning**

Return code	Description
0	No errors encountered. All requests processed successfully.
4	Warning issued. Processing continues. Input/Output error in one or more program libraries.
8	Error - Incomplete data. Processing continues. OPEN or other system service error.
12	Syntax error. Processing terminates. Utility failure or syntax error.
16	Unrecoverable error. No requests processed. SYSIN file cannot be used.
20	Disastrous error. No requests processed. SYSPRINT file cannot be used.

### Message suffix codes

**Table 107. Message suffix codes and associated condition codes**

Suffix	Meaning	Raises minimum condition code to:
I	Information message	0
W	Warning message	4
E	Error message	8
S	Severe error message	12
U	Unrecoverable error message	16

### Message texts and explanations

All numeric completion codes of system services reported in these messages are in hexadecimal unless otherwise stated.

**HSIT001U** HSITAGP COULD NOT OPEN THE INPUT FILE *file*

**Explanation:** A required file could not be opened successfully. In the message text:

*file*

name of file.

**System action:** Processing terminates with condition code 16.

**Operator response:** Correct the file definition and rerun the job.

**System programmer response:** None.

**Module:** HSITAGP

---

**HSIT002S** UNRECOGNIZED STATEMENT TYPE: *stattyp*

**Explanation:** Input text was encountered which does not match any known statement type. In the message text:

***stattyp***

encountered input data.

**System action:** Processing terminates with condition code 12.

**Operator response:** Correct the input and rerun the job.

**System programmer response:** None.

**Module:** HSITAGP

---

**HSIT003S** DUPLICATE VALUE SUPPLIED FOR *stattyp*

**Explanation:** More than one occurrence of the named statement type was encountered, but only one value can be accepted. In the message text:

***stattyp***

name of the statement verb.

**System action:** Processing terminates with condition code 12.

**Operator response:** Remove the redundant statement and rerun the job.

**System programmer response:** None.

**Module:** HSITAGP

---

**HSIT004S** VALUE MISSING IN *stattyp* STATEMENT

**Explanation:** An input statement of the type indicated was encountered, but no non-blanks followed the statement type name. In the message text:

***stattyp***

name of the statement verb.

**System action:** Processing terminates with condition code 12.

**Operator response:** Supply an appropriate value after the statement type name.

**System programmer response:** None.

**Module:** HSITAGP

---

**HSIT005S** VALUE SPECIFIED FOR LICENSED WAS NEITHER "YES" NOR "NO"

**Explanation:** A LICENSED statement was processed which had a value specified other than one of the valid values.

**System action:** Processing terminates with condition code 12.

**Operator response:** Correct the value and rerun the job.

**System programmer response:** None.

**Module:** HSITAGP

---

**HSIT006S** THE *parm* PARAMETER HAD NO SUBPARAMETER VALUE SPECIFIED

**Explanation:** A statement parameter or operand was specified, but the required subparameter, or value of the parameter, was not specified. One cause for this condition is the omission of a parenthesis. In the message text:

***parm***

name of the parameter or operand being processed when the error is detected.

**System action:** Processing terminates with condition code 12.

**Operator response:** Correct the input and rerun the job.

**System programmer response:** None.

**Module:** HSITAGP

---

**HSIT007I** A CLOSING PARENTHESIS ASSUMED FOR *parm*

**Explanation:** End-of-file was raised when processing input statements before an expected close parenthesis was encountered. In the message text:

***parm***

name of the parameter or operand being processed when the error is detected.

**System action:** Processing continues as if the expected close parenthesis had been specified.

**Operator response:** Check that the resulting processing is as expected. Correct the input file for future use, and rerun the job if the desired processing was not performed.

**System programmer response:** None.

**Module:** HSITAGP

**HSIT008S** UNEXPECTED OPEN PARENTHESIS ENCOUNTERED AFTER *parm*

**Explanation:** An open parenthesis was encountered when one was not expected. If this occurred while a parameter or operand was being processed, then it is named in the message. In the message text:

*parm*

name of the parameter or operand being processed when the error is detected.

**System action:** Processing terminates with condition code 12.

**Operator response:** Correct the input file and rerun the job.

**System programmer response:** None.

**Module:** HSITAGP

---

**HSIT009S** UNEXPECTED CLOSE PARENTHESIS ENCOUNTERED AFTER *parm*

**Explanation:** A close parenthesis was encountered when one was not expected. If this occurred while a parameter or operand was being processed, then it is named in the message. In the message text:

*parm*

name of the parameter or operand being processed when the error is detected.

**System action:** Processing terminates with condition code 12.

**Operator response:** Correct the input file and rerun the job.

**System programmer response:** None.

**Module:** HSITAGP

---

**HSIT010S** *parm* IS AN UNKNOWN SELECT PARAMETER

**Explanation:** Input data was encountered which is not a recognized parameter, or operand, of the SELECT statement. In the message text:

*parm*

the encountered input data.

**System action:** Processing terminates with condition code 12.

**Operator response:** Correct the input file and rerun the job.

**System programmer response:** None.

**Module:** HSITAGP

---

**HSIT011S** MEMBER NAME *parm* HAS EMBEDDED BLANK(S)

**Explanation:** The value specified on the TAGMEM statement was not a valid partitioned data set member name, a blank was found within the eight character member name. In the message text:

***parm***

the input value specified on the TAGMEM statement.

**System action:** Processing terminates with condition code 12.

**Operator response:** Correct the input file and rerun the job.

**System programmer response:** None.

**Module:** HSITAGP

---

### **HSIT012S** MISSING OPEN PARENTHESIS AFTER *parm*

**Explanation:** Whilst parsing the SELECT statement looking for a subparameter, or value, in parentheses specified for the parameter or operand named in the message, text was encountered which was not enclosed in parentheses. In the message text:

***parm***

name of the parameter or operand being processed when the error is detected.

**System action:** Processing terminates with condition code 12.

**Operator response:** Correct the input and rerun the job.

**System programmer response:** None.

**Module:** HSITAGP

---

### **HSIT013S** VALUE *data* TOO LONG FOR PARAMETER *parm*

**Explanation:** The length of a subparameter or value was found to exceed the maximum length allowed. The maximum length allowed depends on the specific parameter or operand being processed. For example, a data set name mask exceeding 44 characters in length causes this condition, as will a volume mask exceeding six characters in length. In the message text:

***data***

encountered input data.

***parm***

name of the parameter or operand being processed when the error is detected.

**System action:** Processing terminates with condition code 12.

**Operator response:** Correct the input and rerun the job.

**System programmer response:** None.

**Module:** HSITAGP

---

**HSIT014S**      END OF INPUT REACHED, EXPECTED CONTINUATION IS MISSING

**Explanation:** End-of-file was raised on the input (SYSIN) file, but the SELECT statement currently being processed was expected to continue on the next record.

**System action:** Processing terminates with condition code 12.

**Operator response:** Either supply the missing input data, or remove the continuation character from the last input record. Rerun the job.

**System programmer response:** None.

**Module:** HSITAGP

---

**HSIT017S**      NO VALUE FOR *stattyp* WAS SPECIFIED

**Explanation:** A value for a statement of the type named in the message is required, but was not found in the input file. In the message text:

***stattyp***

the type of input statement required to specify the missing value.

**System action:** Processing terminates with condition code 12.

**Operator response:** Supply a statement of the named type which specifies a value.

**System programmer response:** None.

**Module:** HSITAGP

---

**HSIT019E**      DESERV FAILED - RC=*rc* RS=*rs* FOR DATA SET *dsn*

**Explanation:** A DESERV FUNC=GET\_ALL macro was issued to acquire the member list for a data set, but DESERV issued a non-zero return code. In the message text:

***rc***

the decimal return code issued by DESERV.

***rs***

the hexadecimal reason code issued by DESERV.

***dsn***

the name of the data set being processed by DESERV.

**System action:** The named data set is not processed, and processing continues with the next relevant data set.

**Operator response:** Consult the applicable DFSMS Macro Instructions for Data Sets manual to determine the meaning of the DESERV return and reason codes. Ensure that the named data set is a valid and accessible program library. If necessary, gather appropriate diagnostic materials and contact IBM support.

**System programmer response:** None.

**Module:** HSITAGP

---

**HSIT020S**            DYNAMIC ALLOCATION FAILURE - BPXWDYN RC=*rc*

**Explanation:** BPXWDYN was called to dynamically allocate a required work file, but BPXWDYN issued a non-zero return code. As a result, processing cannot proceed. In the message text:

*rc*

the hexadecimal return code issued by BPXWDYN.

**System action:** Processing terminates with condition code 12.

**Operator response:** Consult the applicable Using REXX and z/OS UNIX System Services manual to determine the meaning of the return code. Examine the job log and messages to see any associated dynamic allocation error message.

**System programmer response:** None.

**Module:** HSITAGP

---

**HSIT022S**            RC=*rc* WAS RETURNED BY PROGRAM *pgm*

**Explanation:** Either the High Level Assembler (program ASMA90) or the Program Binder (program IEWL) was dynamically started to assist with creating the output data, but the named program issued a non-zero return code. In the message text:

*rc*

the decimal return code issued by the named program.

*pgm*

the name of the program that was started.

**System action:** Processing terminates with condition code 12.

**Operator response:** Examine all associated job output to determine if the problem is caused by a correctable environmental error. If so, make the correction and rerun the job. If not, gather all relevant diagnostic materials and contact IBM support.

**System programmer response:** None.

**Module:** HSITAGP

---

**HSIT023I**            PROCESSING TERMINATED DUE TO ENCOUNTERED ERROR CONDITION

**Explanation:** Because of a previously reported error, the product tagging utility is terminating unilaterally, without processing all of the specified program library data sets, and without generating all of the requested program product tagging data.

**System action:** Processing terminates.

**Operator response:** Investigate any previously reported error conditions.

**System programmer response:** None.

**Module:** HSITAGP

---

**HSIT024E** ISITMGD FAILED - RC=*rc* RS=*rs* FOR FILE *file* AND DATA SET *dsn*

**Explanation:** An ISITMGD macro was issued against a program library, but ISITMGD issued a non-zero return code. In the message text:

***rc***

the decimal return code issued by ISITMGD.

***rs***

the decimal reason code issued by ISITMGD.

***file***

the name of the file being processed by ISITMGD.

***dsn***

the name of the data set being processed by ISITMGD.

**System action:** The named data set is not processed, and processing continues with the next relevant data set.

**Operator response:** Consult the applicable DFSMS Macro Instructions for Data Sets manual to determine the meaning of the ISITMGD return and reason codes. Ensure that the named data set is a valid and accessible partitioned data set. If necessary, gather the appropriate diagnostic materials and contact IBM support.

**System programmer response:** None.

**Module:** HSITAGP

---

**HSIT025I** *pgmcnt* PROGRAMS FOUND TO TAG FROM DATA SET *dsn*

**Explanation:** Input processing of the named data set has completed, resulting in data from the reported number of programs being accumulated for subsequent output. In the message text:

***pgmcnt***

the number of programs processed.

***dsn***

the data set name containing the processed programs.

**System action:** Processing continues.

**Operator response:** None required.

**System programmer response:** None.

**Module:** HSITAGP

---

**HSIT026I**            PROCESSING COMPLETE - RC=*rc* AND *pgmcnt* PROGRAMS TAGGED IN TOTAL

**Explanation:** The product tagging utility program HSITAGP has completed processing. This message reports the return code issued by HSITAGP, and the number of programs from which data has been collected during this run. In the message text:

***rc***

the return code issued by the HSITAGP upon termination.

***pgmcnt***

the number of programs processed in this run of HSITAGP.

**System action:** Processing is completed with the displayed return code.

**Operator response:** None required.

**System programmer response:** None.

**Module:** HSITAGP

---

**HSIT028W**            UNABLE TO ACQUIRE ANY PRODUCT MAINTENANCE LEVEL DATE

**Explanation:** After having processed all of the relevant programs, HSITAGP was unable to acquire any date stamp for use as a maintenance level indicator.

**System action:** Blanks are placed in the maintenance level field and processing continues.

**Operator response:** None required.

**System programmer response:** None.

**Module:** HSITAGP

---

**HSIT029S**            *stattyp* STATEMENT VALUE LENGTH EXCEEDS THE ALLOWED MAXIMUM OF *max* BYTES

**Explanation:** The value specified for the named statement type was found to be longer than the maximum allowed. The maximum byte count allowed for a value of this statement type is shown in the message. In the message text:

***stattyp***

the type of input statement being processed.

***max***

number of bytes.

**System action:** Processing terminates.

**Operator response:** Correct the input and rerun the job.

**System programmer response:** None.

**Module:** HSITAGP

---

**HSIT030S**           INVALID TEXT CHARACTER X"*char*" FOUND IN *stattyp* STATEMENT

**Explanation:** The displayed data byte was encountered when processing the value specified for the statement type indicated. The value specified on the statement is expected to be a string. Valid byte values for text data are in the range from X'40' to X'FE' inclusive. The control code encountered is either not valid input, or not valid input in this location. The only control codes that can be used in the input value are SO (X'0E') and SI(X'0F'), when they are used to encapsulate DBCS data. In the message text:

***char***

the hexadecimal value of the invalid text code point.

***stattyp***

the type of input statement being processed.

**System action:** Processing terminates.

**Operator response:** Remove the undisplayable characters from the input value. If using DBCS, ensure that SO precedes DBCS text and SI terminates DBCS text, and that the DBCS text is an even number of valid text bytes.

**System programmer response:** None.

**Module:** HSITAGP

---

**HSIT032E**           NO PROGRAMS ELIGIBLE FOR TAGGING COULD BE FOUND

**Explanation:** No programs met the selection criteria and so the request had no operation to perform. In the message text:

**System action:** Processing terminates with condition code 8.

**Operator response:** If appropriate, modify the request parameters and resubmit the job.

**System programmer response:** None.

**Module:** HSITAGP

---

**HSIT033W**           NOT ALL PROGRAM NAME INCLUSION MASKS WERE MATCHED

**Explanation:** One or more program name inclusion masks did not match any program names in the library. In the message text:

**System action:** Processing continues.

**Operator response:** Correct or remove the inoperative selection filter.

**System programmer response:** None.

**Module:** HSITAGP

---

**HSIT034S** USE THE ANALYZER TO UPDATE THE LKB - OR PROVIDE 'TAGNOW' OVERRIDE PARAMETER

**Explanation:** The preferred method of maintaining the LKB is via the Administration tab of the Analyzer. To continue using the batch Program Tagger an override program parameter of TAGNOW or OLDTAG must be provided. Note that tag members created by HSITAGP will be ignored by the Inquisitor unless the OLDTAG keyword is present in the program parameter string specified for the HSIPINQ program. In the message text:

**System action:** Processing terminates with condition code 12.

**Operator response:** If appropriate, specify a program parameter override and resubmit the job. Otherwise, use the Analyzer to maintain the LKB.

**System programmer response:** None.

**Module:** HSITAGP

---

**HSIT035I** DUPLICATE parm VALUE IGNORED: data.

**Explanation:** A subparameter value was encountered which matched a value previously specified for the same parameter. The duplicate specification is discarded. In the message text:

***parm***

name of the parameter.

***data***

the value found to have been repeated.

**System action:** Processing continues.

**Operator response:** If the value is incorrect then correct it. To prevent the message being issued remove duplicate value specifications.

**System programmer response:** None.

**Module:** HSITAGP

---

**HSIT999U** HSIMSG/HSITMSG FAILURE - MSGID=*msgid* RC=*rc* RS=*rs*

**Explanation:** HSIMSG was called to produce a message text, but the call failed. In the message text:

***msgid***

identifier of the failing message.

***rc***

HSIMSG return code.

***rs***

HSIMSG reason code.

**System action:** Terminates with a condition code of 20.

**Operator response:** Inform the system programmer.

**System programmer response:** Ensure Joblib/Steplib contains the library where the HSITMSG message module resides. If you cannot resolve this issue, contact IBM support.

**Module:** HSITAGP

## HSIX - Inquisitor for z/OS® UNIX™ messages and codes

These messages are issued by the Inquisitor for z/OS and UNIX.

### Return codes

**Table 108. Return codes and their meaning**

Return code	Description
0	No errors encountered. All requests processed successfully.
4	Warning issued.
8	Error - Incomplete data. Processing continues. OPEN or other system service error.
12	Syntax error.
16	Unrecoverable error.
20	The zip I/O subroutine returned an error indication.

### Message suffix codes

**Table 109. Message suffix codes and associated condition codes**

Suffix	Meaning	Raises minimum condition code to:
I	Information message	0
W	Warning message	4
E	Error message	8
S	Severe error message	12
U	Unrecoverable error message	16

### Message texts and explanations

All numeric completion codes of system services reported in these messages are in hexadecimal unless otherwise stated.

---

**HSIX002I** THE SPECIFIED DIRECTORY NAME DOES NOT START WITH A SLASH

**Explanation:** A record from file HSIXROOT was read and was found to start with a non-blank that is not a slash. It is reported in case processing errors result from the non-standard directory name.

**System action:** Processing continues.

**Operator response:** Correct the input if it is incorrect.

**System programmer response:** None.

**Module:** HSIXINQ

---

**HSIX003I** PROGRAM PARAMETER "*parm*" DISCARDED

**Explanation:** The program parameter contained some unrecognized data. In the message text:

*parm*

parameter in error.

**System action:** The displayed part of the program parameter is ignored.

**Operator response:** Correct the program parameter.

**System programmer response:** None.

**Module:** HSIXINQ

---

**HSIX004I** FUNCTION *func* COMPLETED WITH RC=*rc* AND REASON=*rs*

**Explanation:** The named z/OS® UNIX® System Service issued a negative return value. In the message text:

*func*

function name.

*rc*

hexadecimal return code.

*rs*

hexadecial reason code.

**System action:** Processing continues.

**Operator response:** Determine the meaning of the return and reason codes, and correct the problem if appropriate. Information relating to the failing UNIX® function can be found in the *UNIX® System Services Assembler Callable Services* manual. Information relating to the return code and reason code of the failing UNIX® function can be found in the *UNIX® System Services Messages and Codes* manual.

**System programmer response:** None.

**Module:** HSIXINQ

---

**HSIX006E**          RENAME FAILED FOR DATA SET *dsn*

**Explanation:** The rename operation to add one or more extra low-level qualifiers to a data set name as specified by the LLQ program parameter setting did not succeed. The named data set is allocated to either the HSIXZIP or HSIXOUT file. If this message is not followed by an associated explanatory message then an IDCAMS report detailing the results of the rename attempt will have been written to SYSPRINT. In the message text:

***dsn***

name of the HSIXZIP or HSIXOUT data set.

**System action:** The output data set retains its original name.

**Operator response:** Ensure that the specified LLQ string length does not exceed 44 bytes, that any symbols used are valid for this system, and that resultant data set names are not longer than 44 bytes. Examine associated messages to determine the reason for the rename failure.

**System programmer response:** None.

**Module:** HSIXINQ

---

**HSIX007E**          FUNCTION *func* FAILED, RC=*rc*, REASON=*rs*, FOR PATH *pth*

**Explanation:** The named z/OS® UNIX® system service issued a negative return value. In the message text:

***func***

function name.

***rc***

hexadecimal return code.

***rs***

hexadecimal reason code.

***pth***

path in error.

**System action:** Processing continues.

**Operator response:** Determine the meaning of the return and reason codes, and correct the problem if appropriate. Information relating to the failing UNIX® function can be found in the *UNIX® System Services Assembler Callable Services* manual. Information relating to the return code and reason code of the failing UNIX® function can be found in the *UNIX® System Services Messages and Codes* manual.

**System programmer response:** None.

**Module:** HSIXINQ

---

**HSIX008E**          FUNCTION *func* WAS DENIED ACCESS TO PATH *pth*

**Explanation:** The named z/OS® UNIX® System Service issued a return code of hexadecimal 6F which indicates that access was denied. In the message text:

***func***

function name.

***pth***

path in error.

**System action:** Processing continues.

**Operator response:** Grant the user access to the parts of the UNIX® file system to be scanned.

**System programmer response:** None.

**Module:** HSIXINQ

---

**HSIX009S** NO EXECUTABLE SOFTWARE FOUND - NO DATA FOR IMPORT WAS PRODUCED

**Explanation:** All scanning operations failed to find any programs or other executable software, so no data suitable for subsequent processing was created.

**System action:** Terminates with a condition code of 12.

**Operator response:** Correct any selection criteria errors and rerun the job.

**System programmer response:** None.

**Module:** HSIXINQ

---

**HSIX010U** MISSING HSIXOUT AND HSIXZIP FILES

**Explanation:** Neither an HSIXOUT nor an HSIXZIP file is allocated. At least one output file is required.

**System action:** Terminates with a condition code of 16.

**Operator response:** Specify an output file and rerun the job.

**System programmer response:** None.

**Module:** HSIXINQ

---

**HSIX999U** HSIMSG/HSIXMSG FAILURE - MSGID=*msgid* RC=*rc* RS=*rs*

**Explanation:** HSIMSG was called to produce a message text, but the call failed. In the message text:

***msgid***

identifier of the failing message.

***rc***

HSIMSG return code.

*rs*

HSIMSG reason code.

**System action:** Terminates with a condition code of 20.

**Operator response:** Inform the system programmer.

**System programmer response:** Ensure Joblib/Steplib contains the library where the HSIXMSG message module resides. If you cannot resolve this issue, contact IBM support.

**Module:** HSIXINQ

## HSIZ - Usage Monitor messages

These messages are issued by the Usage Monitor.

### Return codes

**Table 110. Return codes and their meaning**

Return code	Description
0	Normal termination.
16	Initialization failed.

### Message suffix codes

**Table 111. Message suffix codes and associated condition codes**

Suffix	Meaning	Raises minimum condition code to:
I	Information message	0
W	Warning message	4
E	Error message	8
S	Severe error message	12
U	Unrecoverable error message	16

### Message texts and explanations

All numeric completion codes of system services reported in these messages are in hexadecimal unless otherwise stated.

**HSIZ001I** USAGE MONITOR INITIALIZING

**Explanation:** The Usage Monitor has been started.

**System action:** Processing continues.

**Operator response:** None required.

**System programmer response:** None.

**Module:** HSIZMON

---

**HSIZ002I**            *csid* DETECTED UNSUPPORTED OPERATING SYSTEM

**Explanation:** The Usage Monitor may not run on an unsupported operating system. In the message text:

*csid*

current system identifier.

**System action:** Processing terminates.

**Operator response:** None required.

**System programmer response:** None.

**Module:** HSIZMON

---

**HSIZ003I**            *csid* USAGE MONITOR NOT APF AUTHORIZED

**Explanation:** The Usage Monitor needs to be executed in an APF authorized environment. In the message text:

*csid*

current system identifier.

**System action:** Processing terminates.

**Operator response:** See System Programmer to correct the error.

**System programmer response:** APF authorize the load libraries that the Usage monitor runs from.

**Module:** HSIZMON

---

**HSIZ005I**            *csid* USAGE MONITOR ALREADY ACTIVE

**Explanation:** The Usage Monitor is already running. Only one concurrent copy can run in an operating system image. In the message text:

*csid*

current system identifier.

**System action:** Processing terminates. The established Usage Monitor task continues.

**Operator response:** None required.

**System programmer response:** None.

**Module:** HSIZMON

---

**HSIZ006I** *csid* USAGE MONITOR QEDIT BUFFER SET FAILED

**Explanation:** A QEDIT issued to set up MODIFY command processing has failed. In the message text:

***csid***

current system identifier.

**System action:** Processing terminates.

**Operator response:** Notify the system programmer.

**System programmer response:** Gather appropriate diagnostic materials and contact IBM support.

**Module:** HSIZMON

---

**HSIZ007I** *csid* USAGE MONITOR MODULE *mod* FAILED - RC=*rc*

**Explanation:** A Usage Monitor subroutine has failed. In the message text:

***csid***

current system identifier.

***mod***

failing module name.

***rc***

decimal return code.

**System action:** Processing terminates.

**Operator response:** Notify the system programmer.

**System programmer response:** Gather appropriate diagnostic materials and contact IBM support.

**Module:** HSIZMON

---

**HSIZ008I** *csid* USAGE MONITOR INITIALIZED - ASID *asid* SET IN AVT *avt*

**Explanation:** An anchor vector table (AVT) has been acquired or reacquired, and has been updated for the current server address space, which has completed initialization. In the message text:

***csid***

current system identifier.

***asid***

ASID number.

***avt***

AVT Address.

**System action:** Processing continues.

**Operator response:** None required.

**System programmer response:** None.

**Module:** HSIZMON

---

**HSIZ009I** DATA WRITTEN TO DSN=*dsn*

**Explanation:** Usage Monitor data has been written to the named data set. In the message text:

*dsn*

data set name of the created output.

**System action:** Processing continues.

**Operator response:** Transfer the named data set to the system where the database resides so it can be processed.

**System programmer response:** None.

**Module:** HSIZMON

---

**HSIZ010E** *csid* USAGE MONITOR - WRITER TASK ENDED - RC=*rc*

**Explanation:** A writer task has ended with a non-zero return code. In the message text:

*csid*

current system identifier.

*rc*

return code of writer task.

**System action:** Processing continues.

**Operator response:** Notify the system programmer.

**System programmer response:** Gather appropriate diagnostic materials and contact IBM support.

**Module:** HSIZMON

---

**HSIZ011E** *csid* USAGE MONITOR - WRITER TASK ABENDED - *Sabend*

**Explanation:** A writer task has ended abnormally. In the message text:

*csid*

current system identifier.

*abend*

abend code from writer task.

**System action:** Processing continues.

**Operator response:** Notify the system programmer.

**System programmer response:** Local reasons for system abends should be investigated. If necessary, gather appropriate diagnostic materials and contact IBM support.

**Module:** HSIZMON

---

**HSIZ012I**           \*\*DATA LOSS\*\* UNUSABLE DSN=*dsn*

**Explanation:** It is likely that Usage Monitor data has been lost because of unexpected behavior by a writer task. Any compressed output data that has been written will probably be unusable. In the message text:

*dsn*

data set name of the created output file.

**System action:** Processing continues.

**Operator response:** Examine any preceding messages to determine the likely cause of the writer task error. If the output data set is complete it can be used, otherwise if the data is compressed it is unusable. If the data set is empty, this fact can be noted and the data set can be deleted. Unless retaining an unusable data set for diagnosis reasons, it can be deleted.

**System programmer response:** Investigate any writer task abends.

**Module:** HSIZMON

---

**HSIZ013I**           *csid* USAGE MONITOR - UNRECOGNIZED PROGRAM PARAMETER IGNORED

**Explanation:** An unrecognized program parameter was specified. In the message text:

*csid*

current system identifier.

**System action:** Processing continues.

**Operator response:** Remove or correct the program parameter.

**System programmer response:** None.

**Module:** HSIZMON

---

**HSIZ014I**           *csid* USAGE MONITOR - COULD NOT OPEN FILE HSIZIN

**Explanation:** The HSIZIN file could not be opened by the Usage Monitor. In the message text:

*csid*

current system identifier.

**System action:** Processing terminates.

**Operator response:** Supply or correct the HSIZIN DD statement in the JCL.

**System programmer response:** None.

**Module:** HSIZMON

---

**HSIZ015I**                    *csid* USAGE MONITOR - COULD NOT OPEN FILE HSIZMSG

**Explanation:** The HSIZMSG file could not be opened by the Usage Monitor. In the message text:

*csid*

current system identifier.

**System action:** Processing terminates.

**Operator response:** Supply or correct the HSIZMSG DD statement in the JCL.

**System programmer response:** None.

**Module:** HSIZMON

---

**HSIZ016I**                    *csid* USAGE MONITOR TERMINATING - INVALID OR MISSING HSIZIN DATA

**Explanation:** At least one HSIZIN input statement was invalid, or input required to be present in the HSIZIN file was missing. In the message text:

*csid*

current system identifier.

**System action:** Processing terminates.

**Operator response:** Examine the HSIZMSG output report. Correct any invalid statements. Ensure a valid data set name prefix was specified.

**System programmer response:** None.

**Module:** HSIZMON

---

**HSIZ017I**                    *csid* USAGE MONITOR TERMINATING - NOW WRITING CAPTURED DATA

**Explanation:** A STOP command has been encountered. The current repository contents are written before the Usage Monitor terminates. In the message text:

*csid*

current system identifier.

**System action:** The Usage Monitor starts a writer task and waits for its completion before terminating.

**Operator response:** None required.

**System programmer response:** None.

**Module:** HSIZMON

---

**HSIZ018I** *csid* USAGE MONITOR HAS NOW TERMINATED

**Explanation:** The Usage Monitor has now freed resources and is about to terminate. In the message text:

*csid*

current system identifier.

**System action:** Processing terminates.

**Operator response:** None required.

**System programmer response:** None.

**Module:** HSIZMON

---

**HSIZ019I** *csid* USAGE MONITOR REPOSITORY FULL - NOW SWITCHING

**Explanation:** The current Usage Monitor data collection repository is full. In the message text:

*csid*

current system identifier.

**System action:** A new repository is created and used for subsequent data collection. A writer task is initiated for the full repository.

**Operator response:** None required.

**System programmer response:** None.

**Module:** HSIZMON

---

**HSIZ020I** *csid* THE SPECIFIED NUMBER WAS TOO SMALL

**Explanation:** The numeric value of a command subparameter was too small to be valid in the command context. In the message text:

*csid*

current system identifier.

**System action:** The command is discarded.

**Operator response:** Correct the numeric value and reissue the command.

**System programmer response:** None.

**Module:** HSIZMON

---

**HSIZ021I**      *csid* THE SPECIFIED NUMBER WAS TOO LARGE

**Explanation:** The numeric value of a command subparameter was too large to be valid in the command context. In the message text:

***csid***

current system identifier.

**System action:** The command is discarded.

**Operator response:** Correct the numeric value and reissue the command.

**System programmer response:** None.

**Module:** HSIZMON

---

**HSIZ022I**      *csid* PASSIVE MODE SET FROM PROGRAM PARAMETER

**Explanation:** PASSIVE was specified in the program parameter. In the message text:

***csid***

current system identifier.

**System action:** The Usage Monitor starts in passive mode unless overridden by input from the HSIZIN file.

**Operator response:** Set the Usage Monitor into collection mode to start data collection.

**System programmer response:** None.

**Module:** HSIZMON

---

**HSIZ023I**      *csid* PROGRAM NAME MASK *mask* NOT ADDED - ALREADY IN TABLE

**Explanation:** A command to add a program name mask to a program mask table was issued, but the mask was already present in the table. In the message text:

***csid***

current system identifier.

***mask***

program mask specified in command.

**System action:** Processing continues.

**Operator response:** None required.

**System programmer response:** None.

**Module:** HSIZMON

---

**HSIZ024I**            *csid* PROGRAM NAME MASK *mask* ADDED TO TABLE

**Explanation:** A command to add a program name mask to a program mask table was issued, and the mask was added successfully. In the message text:

***csid***

current system identifier.

***mask***

program mask specified in command.

**System action:** Processing continues.

**Operator response:** None required.

**System programmer response:** None.

**Module:** HSIZMON

---

**HSIZ025I**            *csid* PROGRAM NAME MASK *mask* NOT DELETED - NOT FOUND IN TABLE

**Explanation:** A command to delete a program name mask from a program mask table was issued, but the mask was not present in the table. In the message text:

***csid***

current system identifier.

***mask***

program mask specified in command.

**System action:** Processing continues.

**Operator response:** None required.

**System programmer response:** None.

**Module:** HSIZMON

---

**HSIZ026I**            *csid* PROGRAM NAME MASK *mask* DELETED FROM TABLE

**Explanation:** A command to delete a program name mask from a program mask table was issued, and the mask was deleted successfully. In the message text:

***csid***

current system identifier.

***mask***

program mask specified in command.

**System action:** Processing continues.

**Operator response:** None required.

**System programmer response:** None.

**Module:** HSIZMON

---

**HSIZ027I** ECSA APPEARS TO BE EXHAUSTED - INCREASE SIZE FOR NEXT IPL

**Explanation:** The Usage Monitor has attempted to acquire storage from ECSA, but was given CSA storage by the system. This indicates that there is insufficient ECSA for the current workloads, and that it should be increased for the next IPL.

**System action:** Processing continues.

**Operator response:** Notify the system programmer.

**System programmer response:** Add approximately 50 to 100 MB to the ECSA size in the system IPL parameters. Check the capacity of the COMMON page data set.

**Module:** HSIZMON

---

**HSIZ028I** ECSA AND CSA APPEAR TO BE EXHAUSTED - INCREASE ECSA NEXT IPL

**Explanation:** The Usage Monitor has attempted to acquire some common storage, but the requested amount was unavailable. This indicates that there is insufficient ECSA for the current workloads, and that it should be increased for the next IPL.

**System action:** Processing continues.

**Operator response:** Notify the system programmer.

**System programmer response:** Add approximately 50 to 100 MB to the ECSA size in the system IPL parameters. Close some applications using CSA. If necessary, commence orderly shutdown and reIPL before the system crashes. Check the capacity of the COMMON page data set.

**Module:** HSIZMON

---

**HSIZ029I** *csid* THERE IS CURRENTLY NO EXCLUDE TABLE

**Explanation:** A request was made to change or display the program name mask exclude table, but there is currently no exclude table. In the message text:

*csid*

current system identifier.

**System action:** Processing continues.

**Operator response:** None required. The EXC command may be used to create a table.

**System programmer response:** None.

**Module:** HSIZMON

---

**HSIZ030I**            *csid* USAGE MONITOR - NO DATA COLLECTED SO SKIPPING WRITE

**Explanation:** Before a writer task was initiated to output the contents of a Usage Monitor repository, it was found that the repository contained no data, and that therefore data output processing could be omitted. In the message text:

***csid***

current system identifier.

**System action:** Processing continues.

**Operator response:** None required.

**System programmer response:** None.

**Module:** HSIZMON

---

**HSIZ032I**            *csid cmd* COMMAND UNKNOWN

**Explanation:** A command was issued but was not recognized. In the message text:

***csid***

current system identifier.

***cmd***

name of the issued command.

**System action:** The command is ignored. Processing continues.

**Operator response:** If necessary, correct and reissue the command.

**System programmer response:** None.

**Module:** HSIZMON

---

**HSIZ033I**            *csid cmd* COMMAND PROCESSED

**Explanation:** A command was issued and has been processed successfully. In the message text:

***csid***

current system identifier.

***cmd***

name of the issued command.

If the system identifier is shown as **UMON-WTR** then the command was issued internally by the writer task. Look under the description of the command for more information.

**System action:**

**System action:** Processing continues.

**Operator response:** None required.

**System programmer response:** None.

**Module:** HSIZMON

---

**HSIZ034I**            *csid cmd* COMMAND HAS INVALID OPERAND

**Explanation:** A command was issued but an invalid operand was encountered. In the message text:

***csid***

current system identifier.

***cmd***

name of the issued command.

**System action:** The command is ignored. Processing continues.

**Operator response:** If necessary, correct and reissue the command.

**System programmer response:** None.

**Module:** HSIZMON

---

**HSIZ035I**            *csid cmd* COMMAND FAILED

**Explanation:** A command was issued but insufficient resources were available to execute it successfully. In the message text:

***csid***

current system identifier.

***cmd***

name of the issued command.

**System action:** The command is ignored. Processing continues.

**Operator response:** Try again after more resources become available.

**System programmer response:** None.

**Module:** HSIZMON

---

**HSIZ036I**            *csid cmd* COMMAND CAUSED NO CHANGE

**Explanation:** A command was issued but the state to be set by the command was found to already exist. In the message text:

***csid***

current system identifier.

***cmd***

name of the issued command.

**System action:** Processing continues.

**Operator response:** None required.

**System programmer response:** None.

**Module:** HSIZMON

---

**HSIZ0371** *csid cmd* COMMAND REJECTED

**Explanation:** A recognized command was issued at a time when the Usage Monitor is unable to process the command. In the message text:

***csid***

current system identifier.

***cmd***

name of the issued command.

**System action:** The command is ignored. Processing continues.

**Operator response:** Try again after the Usage Monitor has freed the resources.

**System programmer response:** None.

**Module:** HSIZMON

---

**HSIZ0381** *csid* CURRENT USAGE MONITOR PROGRAM EXCLUDE LIST:

**Explanation:** A D-X command was issued to display the program name exclude table contents. The active entries are shown after this message. In the message text:

***csid***

current system identifier.

**System action:** The data is displayed and processing continues.

**Operator response:** None required.

**System programmer response:** None.

**Module:** HSIZMON

---

**HSIZ0391** *csid* REPOSITORY SWITCH HAS BEEN QUEUED

**Explanation:** A repository switch was triggered by a SWI or STOP command, or by the current repository becoming full, but a writer task is already active. This message is followed by message [HSIZ040I on page 357](#), which shows the creation timestamp of the active writer task. In the message text:

**csid**

current system identifier.

**System action:** Data collection is suspended. Wait for the current writer task to complete whereupon a new writer task is created, and a new repository is created, and data collection is resumed.

**Operator response:** Check that there are sufficient resources to dispatch the Usage Monitor address space. Check that there are no serialization problems with system components such as device allocation which could be inhibiting writer task processing.

**System programmer response:** None.

**Module:** HSIZMON

---

**HSIZ040I** *csid* WAITING FOR WRITER TASK ATTACHED *ts*

**Explanation:** A repository switch was triggered by a SWI or STOP command, or by the current repository becoming full, but a writer task is already active. This message follows message [HSIZ039I on page 356](#) and shows the creation timestamp of the active writer task. In the message text:

**csid**

current system identifier.

**ts**

Time stamp of write task.

**System action:** Data collection is suspended. Wait for the current writer task to complete whereupon a new writer task is created, and a new repository is created, and data collection is resumed.

**Operator response:** Check that there are sufficient resources to dispatch the Usage Monitor address space. Check that there are no serialization problems with system components such as device allocation which could be inhibiting writer task processing.

**System programmer response:** None.

**Module:** HSIZMON

---

**HSIZ041I** *csid* CURRENT USAGE MONITOR OUTPUT DYNALLOC PARMS:

**Explanation:** A D-A command was issued to display the current output dynamic allocation parameters, which are shown after this message. In the message text:

**csid**

current system identifier.

**System action:** The data is displayed and processing continues.

**Operator response:** None required.

**System programmer response:** None.

**Module:** HSIZMON

---

**HSIZ042I** CURRENT USAGE MONITOR OUTPUT SYSTEM ID IS "*csysplex.csid*"

**Explanation:** A D-I command was issued to display the current system identifier which is to be contained in output header records. In the message text:

***csysplex***

current sysplex name.

***csid***

current system identifier.

**System action:** Processing continues.

**Operator response:** None required.

**System programmer response:** None.

**Module:** HSIZMON

---

**HSIZ043I** *csid* DATA DISCARDED DUE TO QUEUE AREA STORAGE LIMIT

**Explanation:** The Usage Monitor has detected for the first time in the life of the current collection repository that program usage event data has been discarded due to the queue area storage usage limit being reached. This limit was set with the QSZ command. In the message text:

***csid***

current system identifier.

**System action:** Processing continues.

**Operator response:** Adjust the Usage Monitor QSZ setting as appropriate for the particular system. Recycle the Usage Monitor address space to implement the new setting. Ensure that the Usage Monitor address space is running at a higher priority than all CPU-bound workloads. Generally, monitors need to run at a higher priority than the workloads being monitored.

**System programmer response:** None.

**Module:** HSIZMON

---

**HSIZ044I** *csid* SWITCH-AND-WRITE TIME-OF-DAY IS SET TO *hh:mm*

**Explanation:** A D-T command was issued to display the switch-and-write time-of-day setting for this system. In the message text:

***csid***

current system identifier.

**hh**

Hour of the day.

**mm**

minute of the hour.

**System action:** Processing continues.**Operator response:** None required.**System programmer response:** None.**Module:** HSIZMON**HSIZ045I** *csid CREATED area token-addr***Explanation:** A memory object required to hold data was created. In the message text:**csid**

current system identifier.

**area**

purpose of the memory object.

**token**

storage token of the memory object.

**addr**

storage address of the memory object.

**System action:** Processing continues.**Operator response:** None required.**System programmer response:** None.**Module:** HSIZMON**HSIZ046I** *csid DELETED area token-addr***Explanation:** A memory object which was no longer needed was deleted In the message text:**csid**

current system identifier.

**area**

purpose of the memory object.

**token**

storage token of the memory object.

***addr***

storage address of the memory object.

**System action:** Processing continues.

**Operator response:** None required.

**System programmer response:** None.

**Module:** HSIZMON

---

**HSIZ047I**

*csid* USAGE MONITOR - ATTACHING WRITER SEQ-NO-*seqnbr*

**Explanation:** A writer task is being attached to write out repository contents. The writer task sequence number is also reported. The first writer task to run after the Usage Monitor starts has a sequence number of 1. In the message text:

***csid***

current system identifier.

***seqnbr***

sequence number of writer task this run.

**System action:** Processing continues.

**Operator response:** None required.

**System programmer response:** None.

**Module:** HSIZMON

---

**HSIZ048I**

*csid* USAGE MONITOR - IDENTIFY FAILED HEX RC=*rc*

**Explanation:** The Usage Monitor executed an IDENTIFY macro which failed. In the message text:

***csid***

current system identifier.

***rc***

hexadecimal return code of the IDENTIFY macro.

**System action:** Processing terminates.

**Operator response:** Notify the system programmer.

**System programmer response:** Investigate why an IDENTIFY macro would fail with that return code.

**Module:** HSIZMON

---

**HSIZ049I**

*csid* DATA SET NAME MASK NOT DEACTIVATED, NOT FOUND IN LIST

**Explanation:** A command to delete a data set name mask from a data set name mask list was issued, but the mask was not present in the list. In the message text:

***csid***

current system identifier.

**System action:** Processing continues.

**Operator response:** None required.

**System programmer response:** None.

**Module:** HSIZMON

---

### **HSIZ050I** *csid DATA SET NAME MASK mask LIST list*

**Explanation:** A D-D command was issued to display the data set name mask include and exclude lists. These header and trailer lines mark the start and end of the lists. In the message text:

***csid***

current system identifier.

***mask***

INCLUDE or EXCLUDE.

***list***

START or END.

**System action:** Processing continues.

**Operator response:** None required.

**System programmer response:** None.

**Module:** HSIZMON

---

### **HSIZ053I** *csid MONITORING UNIX® PROGRAMS? ans*

**Explanation:** Either a USS command was issued to change the UNIX® program monitoring status or a D-S command was issued. When the answer is YES, the usage of programs fetched from UNIX® files is monitored. When the answer is NO, only the usage of programs from PDS and PDSE libraries is monitored. In the message text:

***csid***

current system identifier.

***ans***

YES or NO.

**System action:** Processing continues.

**Operator response:** None required.

**System programmer response:** None.

**Module:** HSIZMON

---

**HSIZ054I** *csid* MONITORING LINK PACK AREA PROGRAMS? *ans*

**Explanation:** Either an LPA command was issued to change the LPA program monitoring status or a D-S command was issued. When the answer is YES, the usage of programs residing in the Link Pack Area is monitored. When answer is NO, only the usage of programs loaded into address space regions (and sometimes into CSA) is monitored. In the message text:

***csid***

current system identifier.

***ans***

YES or NO.

**System action:** Processing continues.

**Operator response:** None required.

**System programmer response:** None.

**Module:** HSIZMON

---

**HSIZ056I** *csid* PREFER VOLUME SYMBOL OVER SERIAL? *ans*

**Explanation:** Either a SYM command was issued to change the volume symbol status or a D-S command was issued.

- When the answer is YES, a matching system static symbol that evaluates to the volume serial is collected instead of the volume serial, if such a symbol exists; otherwise the actual volume serial is collected. A YES setting might improve data matching when system software platform volume switches take place.
- When the answer is NO, the captured volume serial number is always output.

In the message text:

***csid***

current system identifier.

***ans***

YES or NO.

**System action:** Processing continues.

**Operator response:** None required.

**System programmer response:** None.

**Module:** HSIZMON

---

**HSIZ058I**      *csid* FILE HSIZIN IS NOT ALLOCATED - CANNOT PERFORM REFRESH

**Explanation:** A REF command was issued to refresh settings from commands in the HSIZIN file, but the HSIZIN file had been freed, and was no longer allocated to the Usage Monitor. In the message text:

*csid*

current system identifier.

**System action:** The refresh operation is suppressed and processing continues.

**Operator response:** Ensure FREE=CLOSE is not specified in the HSIZIN JCL DD statement. Recycle the Usage Monitor to refresh the settings if necessary.

**System programmer response:** None.

**Module:** HSIZMON

---

**HSIZ059I**      *csid* REFRESH PERFORMED WITH NO ERRORS

**Explanation:** A REF command was issued to refresh settings from commands in the HSIZIN file. All commands in the HSIZIN file were completed successfully. In the message text:

*csid*

current system identifier.

**System action:** Processing continues.

**Operator response:** None required.

**System programmer response:** None.

**Module:** HSIZMON

---

**HSIZ060I**      *csid* REFRESH PERFORMED BUT ERROR(S) FOUND

**Explanation:** A REF command was issued to refresh settings from commands in the HSIZIN file. At least one command in the HSIZIN file resulted in an error. In the message text:

*csid*

current system identifier.

**System action:** Processing terminates.

**Operator response:** Examine the output in the HSIZMSG file to determine the problem(s).

**System programmer response:** None.

**Module:** HSIZMON

**HSIZ063I**            *csid* COLLECTING "UNKNOWN" EVENTS? *ans*

**Explanation:** Either a UNK command was issued or a D-S command was issued. When the answer is YES, this message indicates that the Usage Monitor logs events with incomplete data which would not normally be collected. Data base content is not affected. In the message text:

***csid***

current system identifier.

***ans***

YES or NO.

**System action:** Processing continues.

**Operator response:** None required.

**System programmer response:** None.

**Module:** HSIZMON

---

**HSIZ064I**            *csid* WILL WRITER TASK COMPRESS THE DATA? *ans*

**Explanation:** Either a ZIP command was issued to change the output compression setting or a D-S command was issued. When the answer is YES, the writer task writes compressed data to reduce I/O volumes. In the message text:

***csid***

current system identifier.

***ans***

YES or NO.

**System action:** Processing continues.

**Operator response:** None required.

**System programmer response:** None.

**Module:** HSIZMON

---

**HSIZ065I**            *csid* WILL WRITER TASK CORRECT LINKLIST DSN? *ans*

**Explanation:** Either an LLC command was issued or a D-S command was issued. When the answer is YES, the writer task will perform a BLDL for programs known to have been fetched from the link list, and each output record for such programs will be altered to reflect the link list data set name that the writer task found the program in. In the message text:

***csid***

current system identifier.

**ans**

YES or NO.

**System action:** Processing continues.**Operator response:** None required.**System programmer response:** None.**Module:** HSIZMON**HSIZ066I***csid nbr* IDLE ELEMENT(S) "LOST" DUE TO ZERO POINTER

**Explanation:** The Usage Monitor was terminating normally when a storage accounting discrepancy was discovered. The storage for the idle element chain was being freed when it was found to be terminated by a zero pointer before the expected number of elements had been processed. The most probable cause is a storage overlay. This may or may not represent a Usage Monitor logic error. The size of common storage which may be unusable until the next IPL can be calculated by multiplying the element count by the size of an element. In the message text:

**csid**

current system identifier.

**nbr**

the number of elements being reported.

**System action:** Termination continues.

**Operator response:** Determine if the size of the potential loss of common storage is likely to impact upon system stability, and take the appropriate action. Ensure that all appropriate maintenance has been applied.

**System programmer response:** None.**Module:** HSIZMON**HSIZ068I***csid* COLLECTING JOB ACCOUNTS NOW? *ans*

**Explanation:** A D-S command was issued. When the answer is YES, job account data is currently being collected as program usage events are recorded. When the answer is NO, job account data is not being collected currently. In the message text:

**csid**

current system identifier.

**ans**

YES or NO.

**System action:** Processing continues.**Operator response:** None required.**System programmer response:** None.

**Module:** HSIZMON

---

**HSIZ069I**            *csid* COLLECTING JOB ACCOUNTS LATER? *ans*

**Explanation:** Either a JAC command was issued or a D-S command was issued. When the answer is YES, job account data will be collected after the next Usage Monitor collection repository switch. If the answer is NO, job account data will not be collected from that time onwards. In the message text:

***csid***

current system identifier.

***ans***

YES or NO.

**System action:** Processing continues.

**Operator response:** None.

**System programmer response:** None.

**Module:** HSIZMON

---

**HSIZ070I**            *csid* COLLECTING REGISTERED PRODUCT DATA NOW? *ans*

**Explanation:** A D-S command was issued. When the answer is YES, registered software product data from SMF is currently being collected by the Usage Monitor. When the answer is NO, then this SMF data is not being currently collected. In the message text:

***csid***

current system identifier.

***ans***

YES or NO.

**System action:** Processing continues.

**Operator response:** None.

**System programmer response:** None.

**Module:** HSIZMON

---

**HSIZ071I**            *csid* COLLECTING REGISTERED PRODUCT DATA LATER? *ans*

**Explanation:** Either a PRS command was issued or a D-S command was issued. When the answer is YES, registered software product data from SMF will be collected after the next Usage Monitor collection repository switch. When the answer is NO, this SMF data will not be collected after the next switch. In the message text:

***csid***

current system identifier.

**ans**

YES or NO.

**System action:** Processing continues.**Operator response:** None.**System programmer response:** None.**Module:** HSIZMON**HSIZ072I***csid* COLLECTING DYNAMIC CAPACITY DATA NOW? *ans***Explanation:** A D-S command was issued. When the answer is YES, hardware capacity information is currently being collected by the Usage Monitor. When the answer is NO, hardware capacity information is not being currently collected. In the message text:**csid**

current system identifier.

**ans**

YES or NO.

**System action:** Processing continues.**Operator response:** None.**System programmer response:** None.**Module:** HSIZMON**HSIZ073I***csid* COLLECTING DYNAMIC CAPACITY DATA LATER? *ans***Explanation:** Either a CAP command was issued or a D-S command was issued. When the answer is YES, the Usage Monitor will collect hardware capacity information after the next Usage Monitor collection repository switch. When the answer is NO, the hardware capacity information will not be collected after the next switch. In the message text:**csid**

current system identifier.

**ans**

YES or NO.

**System action:** Processing continues.**Operator response:** None.**System programmer response:** None.**Module:** HSIZMON

---

**HSIZ074I** *csid* OUTPUT NAMES OF COLLECTED USERS? *ans*

**Explanation:** Either a UNM command was issued or a D-S command was issued. When the answer is YES, collected user names will be included in the data output by the Usage Monitor writer task. When the answer is NO, user names will not be written to the output data set. Even if the answer is YES, no user names will be output if no user information was collected. In the message text:

***csid***

current system identifier.

***ans***

YES or NO.

**System action:** Processing continues.

**Operator response:** None.

**System programmer response:** None.

**Module:** HSIZMON

---

**HSIZ075I** *csid* COLLECTING USER INFORMATION NOW? *ans*

**Explanation:** A D-S command was issued. When the answer is YES, the identifier and name of each program user is currently being collected by the Usage Monitor. When the answer is NO, these user details are not being currently collected. In the message text:

***csid***

current system identifier.

***ans***

YES or NO.

**System action:** Processing continues.

**Operator response:** None.

**System programmer response:** None.

**Module:** HSIZMON

---

**HSIZ076I** *csid* COLLECTING USER INFORMATION LATER? *ans*

**Explanation:** Either a UID command was issued or a D-S command was issued. When the answer is YES, the identifier and name of each program user will be collected after the next Usage Monitor collection repository switch. When the answer is NO, these userid details will not be collected after the next switch. In the message text:

***csid***

current system identifier.

**ans**

YES or NO.

**System action:** Processing continues.

**Operator response:** None.

**System programmer response:** None.

**Module:** HSIZMON

---

**HSIZ077I**      *csid* COLLECTING JOB NAMES NOW? *ans*

**Explanation:** A D-S command was issued. When the answer is YES, the names of jobs using programs are currently being collected by the Usage Monitor. When the answer is NO, only generic address space type data such as JOB, STC, and TSU is currently being collected instead of individual job names. In the message text:

**csid**

current system identifier.

**ans**

YES or NO.

**System action:** Processing continues.

**Operator response:** None.

**System programmer response:** None.

**Module:** HSIZMON

---

**HSIZ078I**      *csid* COLLECTING JOB NAMES LATER? *ans*

**Explanation:** Either a JNM command was issued or a D-S command was issued. When the answer is YES, the names of jobs using programs will be collected after the next Usage Monitor collection repository switch. When the answer is NO, only generic address space type data such as JOB, STC, and TSU will be collected after the next switch instead of individual job names. In the message text:

**csid**

current system identifier.

**ans**

YES or NO.

**System action:** Processing continues.

**Operator response:** None.

**System programmer response:** None.

**Module:** HSIZMON

---

**HSIZ079I** *csid* ALLOWING CICS® EVENT COLLECTION? *ans*

**Explanation:** A D-S command was issued. When the answer is YES, this message indicates that CICS® event collection from suitably customized CICS® regions is enabled. When the answer is NO, CICS® generated program usage information will not be collected. In the message text:

***csid***

current system identifier.

***ans***

YES or NO.

**System action:** Processing continues.

**Operator response:** None required.

**System programmer response:** None.

**Module:** HSIZMON

---

**HSIZ080I** *csid dsn - mct* MATCHES

**Explanation:** Displays the dataset name mask for a D-D command. In the message text:

***csid***

current system identifier.

***dsn***

data set name.

***mct***

match count.

**System action:** Processing continues.

**Operator response:** None required.

**System programmer response:** None.

**Module:** HSIZMON

---

**HSIZ081I** *csid* MONITORING PREVIOUSLY RUNNING PROGRAMS? *ans*

**Explanation:** A D-S command was issued. When the answer is YES, this message indicates usage data for programs resident in the regions of jobs which are older than the current Usage Monitor repository and which have SMF interval recording active will be collected. When the answer is NO, there will be no usage data collected for programs that were running before the current repository was created and do not terminate before the repository collection period ends. In the message text:

***csid***

current system identifier.

**ans**

YES or NO.

**System action:** Processing continues.**Operator response:** None required.**System programmer response:** None.**Module:** HSIZMON**HSIZ082I***csid* RETAINING ALL BATCH JOB IDENTIFIERS? *ans*

**Explanation:** Either a JID or a D-S command was issued. When the answer is YES, the message indicates that data for batch jobs with different JES job identifiers will not be aggregated together but will be reported as usage by separate jobs. When the answer is NO, data for usage of programs will be aggregated only by userid and job name, and only the most recent job identifier will be retained. Aggregation corresponding to the NO answer is always used for started tasks and TSO sessions. In the message text:

**csid**

current system identifier.

**ans**

YES or NO.

**System action:** Processing continues.**Operator response:** None required.**System programmer response:** None.**Module:** HSIZMON**HSIZ083I***csid* ADJUSTING FOR HYPERVISOR TIME OFFSET? *ans*

**Explanation:** Either a HOF or a D-S command was issued. When the answer is YES, the message indicates that timestamps in collected data will be adjusted by subtracting the hypervisor time offset from the z/OS® date and time. When the answer is NO, the unaltered local z/OS® date and time will be used in the collected data. In the message text:

**csid**

current system identifier.

**ans**

YES or NO.

**System action:** Processing continues.**Operator response:** None required.**System programmer response:** None.

**Module:** HSIZMON

---

**HSIZ084I**      *csid* REPORTING TCPIP HOST DETAILS? *ans*

**Explanation:** Either an IPH or a D-S command was issued. When the answer is YES the message indicates that the TCPIP host details (name and address) will be reported in the usage data file. When the answer is NO then the Usage Monitor will not report any TCPIP host information. In the message text:

***csid***

current system identifier.

***ans***

YES or NO.

**System action:** Processing continues.

**Operator response:** None required.

**System programmer response:** None.

**Module:** HSIZMON

---

**HSIZ085I**      *csid cmd* NO LONGER SUPPORTED

**Explanation:** A command was issued that is no longer a functional Usage Monitor command. In the message text:

***csid***

current system identifier.

***cmd***

name of the issued command.

**System action:** The command is ignored. Processing continues.

**Operator response:** Do not issue this command.

**System programmer response:** None.

**Module:** HSIZMON

---

**HSIZ086I**      *csid* COLLECTING APF LIBRARY DETAILS? *ans*

**Explanation:** Either an APF or a D-S command was issued. When the answer is YES the message indicates that the volumes and data set names of APF authorized libraries will be collected and written in the output data. This information is not collected when the answer is NO. In the message text:

***csid***

current system identifier.

**ans**

YES or NO.

**System action:** Processing continues.**Operator response:** None required.**System programmer response:** None.**Module:** HSIZMON**HSIZ087I**      *csid* ACTIVE LONG-RUNNING PROGRAM NAME LIST**Explanation:** A D-L command was issued to display the long-running program name list. The active entries are shown after this message. In the message text:***csid***

current system identifier.

**System action:** The data is displayed and processing continues.**Operator response:** None required.**System programmer response:** None.**Module:** HSIZMON**HSIZ088I**      *csid* COLLECTING USAGE FROM TEMPORARY DATA SETS? *ans***Explanation:** Either a TMP or a D-S command was issued. When the answer is YES the message indicates that usage from programs fetched from temporary data sets will be collected and written in the output data. Usage data about these programs will be discarded when the answer is NO. In the message text:***csid***

current system identifier.

***ans***

YES or NO.

**System action:** Processing continues.**Operator response:** None required.**System programmer response:** None.**Module:** HSIZMON**HSIZ089I**      *csid* ALLOWING IMS USAGE COLLECTION? *ans*

**Explanation:** A D-S command was issued. When the answer is YES this message indicates that usage of IMS-managed programs will be collected. Usage of IMS-managed programs will not be collected when the answer is NO. In the message text:

***csid***

current system identifier.

***ans***

YES or NO.

**System action:** Processing continues.

**Operator response:** None required.

**System programmer response:** None.

**Module:** HSIZMON

---

**HSIZ090I** *csid* ALL *type* ENTRIES HAVE BEEN DEACTIVATED

**Explanation:** A DEL, IDD or XDD command was issued with \*ALL\* being the only specified mask. As a result, all of the relevant type of filtering mask entries were deactivated. The filtering made inactive by the DEL, IDD or XDD command is of the type set by EXC, IDS or XDS commands, respectively. In the message text:

***csid***

current system identifier.

***type***

EXC, IDS or XDS.

**System action:** Processing continues.

**Operator response:** None required.

**System programmer response:** None.

**Module:** HSIZMON

---

**HSIZ091I** *csid* DEFAULT *type* EXCLUSION ENTRIES ARE NOW ACTIVE

**Explanation:** An EXC or XDS command was issued with \*DFLT\* being the only specified mask. As a result, all of the relevant type of default exclusion mask entries are now active. When the reported type is PROGRAM, program name filtering has been reset to the shipped default. When the reported type is DATA SET, all the default data set exclusion entries have been made active without altering user specified data set name filtering. In the message text:

***csid***

current system identifier.

***type***

PROGRAM or DATA SET.

**System action:** Processing continues.

**Operator response:** None required.

**System programmer response:** None.

**Module:** HSIZMON

---

### **HSIZ092I**            *csid* COLLECTING LINKLIST LIBRARY DETAILS? *ans*

**Explanation:** Either a LNK or a D-S command was issued. When the answer is YES the message indicates that the volumes and data set names of linklist libraries will be collected and written in the output data. This information is not collected when the answer is NO. In the message text:

***csid***

current system identifier.

***ans***

YES or NO.

**System action:** Processing continues.

None required.

**System programmer response:** None.

**Module:** HSIZMON

---

### **HSIZ201I**            DYNALLOC FAILURE RC=*rc* ERROR=*s99error* INFO=*s99info* DSN=*dsn*

**Explanation:** The writer task could not dynamically allocate a new output data set. In the message text:

***rc***

DYNALLOC return code.

***s99error***

dynamic allocation reason code (DARC).

***s99info***

dynamic allocation information code.

***dsn***

name of the data set being allocated.

**System action:** Processing of the repository is terminated, and the data lost.

**Operator response:** Correct the cause of the allocation failure. If necessary, use the DSN, PRI, SEC, and UNT commands to customize the allocation request for your installation. Note: The meanings of most DARC values are usually available in the appendix of the ISPF Tutorial.

**System programmer response:** None.

**Module:** HSIZ0203

---

**HSIZ202I**            USAGE MONITOR - COMPRESSION SUBROUTINE ERROR

**Explanation:** While processing repository data the compression subroutine encountered an error. The error message from the compression subroutine immediately follows this message.

**System action:** Processing of the repository is terminated, and the data lost.

**Operator response:** Correct the error described in the message from the compression subroutine. If you cannot resolve this issue, gather appropriate diagnostic materials and contact IBM support.

**System programmer response:** None.

**Module:** HSIZ0203

---

**HSIZ206I**            *errmsg*

**Explanation:** The HSISHRNK compression routine issued an error message which is displayed. In the message text:

*errmsg*

error message from HSISHRNK.

**System action:** The message is preceded by message [HSIZ202I on page 376](#).

**Operator response:** Examine the message for further information.

**System programmer response:** None.

**Module:** HSIZ0203

---

**HSIZ301I**            DESERV FUNC=EXIT RC=*rc* REASON=*rs*

**Explanation:** DESERV FUNC=EXIT issued a non-zero return code. In the message text:

*rc*

return code from DESERV.

*rs*

reason code from DESERV.

**System action:** The DESERV exit is not installed.

**Operator response:** Notify the system programmer.

**System programmer response:** Research the DESERV feedback to determine why the exit could not be installed.

**Module:** HSIZ0203

---

**HSIZ302I** CSVDYNEX ADD (*excd*) RC=*rc* REASON=*rs*

**Explanation:** CSVDYNEX ADD issued a non-zero return code. An exit could not be dynamically defined for the named exit point. In the message text:

***excd***

dynamic exit point name.

***rc***

return code from CSVDYNEX.

***rs***

reason code from CSVDYNEX.

**System action:** The SMF exit is not installed.

**Operator response:** Notify the system programmer.

**System programmer response:** Research the CSVDYNEX feedback to determine why the exit could not be installed. Ensure that IEFU84 is an active SMF exit for the system or subsystem. If you cannot resolve this issue, gather appropriate diagnostic materials and contact IBM support.

**Module:** HSIZ0203

---

**HSIZ303I** ATTRIBUTE MISMATCH - *mod* NOT INSTALLED

**Explanation:** The examined SVC table entry did not have the expected attributes. In the message text:

***mod***

module name.

**System action:** The SVC intercept is not installed.

**Operator response:** Notify the system programmer.

**System programmer response:** Gather appropriate diagnostic materials and contact IBM support.

**Module:** HSIZ0203

---

**HSIZ306I** BAD *statnm* ENTRY PGM=*pgm* JOB=*jbn* USER=*user* ID=*id* DATE=*date* REJECTED

**Explanation:** An invalid work element has been detected and some of its contents are displayed. In the message text:

***statnm***

status name.

***pgm***

program name.

***jbn***

job name.

***user***

user name.

***id***

id name.

***date***

date.

**System action:** Attempted to dump some data to HSIZSNAP if the file is allocated, and will then try to free the work element without processing its contents.

**Operator response:** Notify the system programmer.

**System programmer response:** The problem is indicative of a storage overlay. Gather appropriate diagnostic materials and contact IBM support.

**Module:** HSIZ0203

---

**HSIZ307I** *csid* SCAN OF *volume* VTOC ABENDED -S *cde*

**Explanation:** A scan of the named volume abended with the reported abend code. The scan was performed to find the data set name of a program library that is in use. In the message text:

***csid***

current system identifier.

***volume***

volume where VTOC resides.

***cde***

abend code from VTOC scan.

**System action:** Processing continues.

**Operator response:** Notify the system programmer.

**System programmer response:** Check the named volume for error conditions. If necessary, gather appropriate diagnostic materials and contact IBM support.

**Module:** HSIZMON

---

**HSIZ310I** MODULE *mod* INSTALLED AT ADDRESS *loadpt* SIZE *size*

**Explanation:** The Usage Monitor has dynamically loaded a module into common storage and will now register it in DLPA. In the message text:

***mod***

module name.

**loadpt**

module load point.

**size**

module size.

**System action:** Processing continues.

**Operator response:** None.

**System programmer response:** None.

**Module:** HSIZ0203

---

**HSIZ311I** CSVDYLPA RC=*rc* RS=*rs* FOR *mod*

**Explanation:** The Usage Monitor attempted to register a newly installed module in DLPA, but CSVDYLPA issued a non-zero return code. In the message text:

***rc***

decimal return code issued by CSVDYLPA.

***rs***

hexadecimal reason code issued by CSVDYLPA.

***mod***

name of the module being registered.

**System action:** Processing continues.

**Operator response:** Notify the system programmer.

**System programmer response:** Investigate why the named module could not be registered in the current DLPA configuration.

**Module:** HSIZ0203

---

**HSIZ999U** HSIMSG/HSIZMSG FAILURE - MSGID=*msgid* RC=*rc* RS=*rs*

**Explanation:** HSIMSG was called to produce a message text, but the call failed. In the message text:

***msgid***

identifier of the failing message.

***rc***

HSIMSG return code.

***rs***

HSIMSG reason code.

**System action:** Terminates with a condition code of 20.

**Operator response:** Inform the system programmer.

**System programmer response:** Ensure Joblib/Steplib contains the library where the HSIMSG message module resides. If you cannot resolve this issue, gather appropriate diagnostic materials and contact IBM support.

**Module:** HSIZMON

# Appendix. Description of output message content

Messages generated during batch processing are explained in detail here.

## Inquisitor

For each request based on scanning one or more VTOCs, the z/OS Inquisitor produces a VTOC Statistics Report unless the NOVSR keyword appears in the program parameter string. The format of this report will change marginally after the PTF for APAR OA61701 is applied.

The pre-OA61701 column heading is displayed as:

```
VOLUME DVNO STOGROUP TCBAADR-ID START-&-STOP-TIME WT-DELAY ERROR-CD VOL-CYL VTOCTRK
IOERR DSCB DSCB-0 VOL-DS SCAN-DS
```



**Note:** The `ERROR-CD` column may be relabeled as `(MAP-TO)` if logical volume mapping is used.

The post-OA61701 column heading is displayed as:

```
VOLUME MAP-TO DVNO STOGROUP TCBAADR-ID START-&-STOP-TIME WT-DELAY ERROR-CD VOL-CYL VTOCTRK
IOERR DSCB VOL-DS SCAN-DS SCAN-PGMS
```

**Table 112. Volume Statistics Report column headings**

Item	Description
VOLUME	Volume serial number.
DVNO	Device number.
MAP-TO	Logical volume mapped to if mapped.
STOGROUP	SMS storage group name.
TCBAADR-ID	Subtask TCB address and subtask number.
START-&-STOP-TIME	Start and stop times of volume scan by subtask.
WT-DELAY	Main task idle time waiting for this volume scan to complete.
ERROR-CD	Subtask processing error indicator.
VOL-CYL	Number of cylinders provided by the volume.
VTOCTRK	VTOC size in tracks.
IOERR	VTOC I/O error count.
DSCB	VTOC size in DSCBs.
DSCB-0	Number of DSCBs currently unused.
VOL-DS	Number of data sets on the volume.

**Table 112. Volume Statistics Report column headings (continued)**

Item	Description
SCAN-DS	Number of data sets on the volume selected for scanning.
SCAN-PGMS	Number of scanned programs on the volume.

**ZCAT**

When the VFY=Y setting is active, the ZCAT program reads the main output data set (which is allocated to the ZCATOUT DD) to ensure that it can be processed. This output verification phase was added to assist with tracking file corruptions as files are transferred from systems where the data is collected to systems where the data is processed.

The ZCATOUT Verification Report produces statistics about the contents of the ZCATOUT file and issues a message regarding the success or failure of the verification process.

The messages have the following format:

```
count record read of type type
```

where *count* is the record count and *type* is the first two characters of the record. After the subtotal of each record type is reported, the total number of records in the file is displayed.

An example of the report contents is:

```
8 records read of type UM
151 records read of type *C
2531 records read of type *D
16 records read of type *E
287 records read of type *F
216 records read of type *L
8 records read of type *P
382 records read of type *R
3599 records read from ZCATOUT file
```

```
** ZCATOUT file verify result: SUCCESS
```

If an error such as a record count mismatch is discovered, then other relevant messages may be issued, followed by this message:

```
** ZCATOUT file verify result: FAILURE
```

The step completion code is set to 16 to indicate verification failure.

**Table 113. Current types of Usage Monitor records (in sequence written by Usage Monitor)**

Record type	Description
UM	Header record.
*E	Header Extension record.
*F	Filter description record.

**Table 113. Current types of Usage Monitor records (in sequence written by Usage Monitor) (continued)**

Record type	Description
*P	Registered Product usage record.
*R	Registered Product state record.
*C	Capacity record.
*L	Subtask TCB address and subtask number.
*A	APF authorized library record.
*U	User name record.
*D	Detail program usage record.

## IQIMPORT

When each library is matched, several statistical messages are generated that tell you what has transpired during the matching process. See the following example:

```
modules(processed:8,ignored:0),matched(product:0,UNKNOWN:0,none:8),loaded(identified:
0,unidentified:8)
```

Item	Description
Modules	<b>processed</b> - Total number of modules processed by IQIMPORT in the library. <b>ignored</b> - Total number of modules ignored.
Matched	<b>product</b> - How many modules are matched to a product. <b>UNKNOWN</b> - If there are modules known in the GKB that are not matched to a product then this is the number of modules. If 0, then none of the modules are defined in the GKB. <b>none</b> - Number of modules in the library known in the GKB. If 0, then all modules are known in the GKB.
Loaded	<b>Identified</b> - This figure signifies how many modules are associated to a product. <b>unidentified</b> - This indicates how many modules are not identified in the library.

As each library is matched the log indicates each scorecard for a given GKB or LKB entry and the values associated with each match. See the following example:

```
Initial scores
=====
G , ProdVerID = 2123G, Num LMODs Matched = 286/292, Version Ident = 0%, Product Ident
= 97%, score = 79%
```

Item	Description
GKB entry	<b>G</b> - Indicates scorecard is taken from the GKB. <b>L</b> – Indicates entry comes from the LKB and is user defined.
ProdVerID	Each entry in the GKB has a unique id for each version of a product. This data is used by support to find out what happened during the matching process and why some entries were not taken.
Num LMODs Matched	Indicates how many load modules are matched to the data for the given PRODVER entry. In the above example, 286 modules out of 292 in the GKB are deemed to have been identified in the library out of 292 in total in the GKB.
Version Ident	Indicates the percentage of a match to a specific version. The higher the percentage the better the match.
Product Ident	In the above example, the figure indicates the product is identified but the Version is not.
score	Overall score for the scorecard entry. This score is used by the match engine after all scorecards are matched to determine what product and version the modules in the library belong to.

At the end of IQIMPORT processing a summary report is created.

```

=====
IQ Import statistics for SID:OMU3
=====
New Libraries                42
Library records - imported   42
Library records - ignored    0
Module records - imported    5487
Module records - ignored     0
Modules matched (product)    5412
Modules matched (UNKNOWN) - insufficient score  8
Modules matched (none) - not found in KB  67
Modules migrated(identified) 5420
Modules migrated(unidentified) 67
CSECTs migrated             319
Channel Path records        10
Control Unit records

```

Item	Description
New Libraries	Number of new libraries processed during IQIMPORT.
Library records	<b>imported</b> – The number of libraries imported into the Repository. <b>ignored</b> – The number of libraries not imported into the Repository. These could be distribution libraries that are filtered out by the import process.
Module records	<b>imported</b> – The number of modules imported into the Repository.

Item	Description
	<b>ignored</b> – The number of modules not imported into the Repository. This could be because they are in a library that is filtered out.
Modules matched	<b>product</b> – The number of modules successfully matched to a product. <b>UNKNOWN</b> – insufficient score – The number of modules known, but not enough to register as a known version. <b>none</b> – The number of modules not found in the GKB.
Modules migrated	<b>Identified</b> – The number of modules identified to a product that are migrated to the Repository. <b>unidentified</b> – The number of module unidentified that are migrated to the Repository.
CSECTs migrated	Number of CSECTs migrated to the Repository. For CSECTs to be migrated, the IQ data must be scanned with parameter SCANPGM and keyword FULLIDR otherwise no CSECT data is collected.
Channel Path records	Number of channel paths found.
Control unit records	Number of Control units found. These records are collected using the SCANDE command in the Inquisitor.

## USAGE IMPORT

When usage data is imported into a Repository, all the data imported is displayed. Multiple usage data can be imported at the same time from the same system or multiple systems. As each data is imported, a key is generated for each period.

```
Unique ID key from input file: UIMP_IZP5_0320210808000000_0012
Processed:UIMP_IZP5_0320210808000000_0012 Elapsed time: 0 Hrs, 00 Mins, 01 Secs
```

The above example indicates that the data item is the 12th item being imported from the data file. This data is probably coming from a file that has been processed by ZCAT. The elapsed time shows you how long it takes to process the file.

At the end of Usage Import processing a summary report is created. See the below example.

```
Input Record Statistics
Number of header records read      = 8
Number of user records read        = 123
Number of detail records read      = 6015
Number of product usage records read = 0
Number of hardware capacity records read = 8
Number of product registration records read = 445
Number of registered product usage records read = 32
Number of machine resource records read = 24
-----
Total number of input records read = 6655

Earliest period in this usage file: Dec-2018
Latest period in this usage file: Jun-2019
```

Usage Import run completed.

Item	Description
Number of header records read	Figure indicates number of LPARs processed during Usage Import.
Number of user records read	Figure indicates total number of individual user records collected. For example, TSO ID and STC ID.
Number of detail records read	Total number of usage records processed and imported into Repository.
Number of product usage records read	Obsolete. To be removed.
Number of hardware capacity records read	Figure indicates number of LPARS capacity records read. Usually one per LPAR.
Number of product registration records read	Number of records read from Usage file containing registered products.
Number of registered product usage records read	Number of records read from Usage file indicating which products have been used.
Number of machine resource records read	Resource records read from the Usage Data showing what other resources are available on the machine.

# Notices

## March 2023

This information was developed for products and services offered in the U.S.A.

HCL® may not offer the products, services, or features discussed in this document in other countries. Consult your local HCL® representative for information on the products and services currently available in your area. Any reference to an HCL® product, program, or service is not intended to state or imply that only that HCL® product, program, or service may be used. Any functionally equivalent product, program, or service that does not infringe any HCL® intellectual property right may be used instead. However, it is the user's responsibility to evaluate and verify the operation of any non-HCL product, program, or service.

HCL® may have patents or pending patent applications covering subject matter described in this documentation. The furnishing of this documentation does not give you any license to these patents. You can send license inquiries, in writing, to:

IBM Director of Licensing  
IBM Corporation  
North Castle Drive  
Armonk, NY 10504-1785  
U.S.A.

For license inquiries regarding double-byte character set (DBCS) information, contact the IBM® Intellectual Property Department in your country or send inquiries, in writing, to:

Intellectual Property Licensing  
Legal and Intellectual Property Law  
IBM Japan Ltd.  
1623-14, Shimotsuruma, Yamato-shi  
Kanagawa 242-8502 Japan

**The following paragraph does not apply to the United Kingdom or any other country where such provisions are inconsistent with local law:** INTERNATIONAL BUSINESS MACHINES CORPORATION PROVIDES THIS PUBLICATION "AS IS" WITHOUT WARRANTY OF ANY KIND, EITHER EXPRESS OR IMPLIED, INCLUDING, BUT NOT LIMITED TO, THE IMPLIED WARRANTIES OF NON-INFRINGEMENT, MERCHANTABILITY OR FITNESS FOR A PARTICULAR PURPOSE. Some states do not allow disclaimer of express or implied warranties in certain transactions, therefore, this statement may not apply to you.

This information could include technical inaccuracies or typographical errors. Changes are periodically made to the information herein; these changes will be incorporated in new editions of the publication. HCL® may make improvements and/or changes in the product(s) and/or the program(s) described in this publication at any time without notice.

Any references in this information to non-HCL Web sites are provided for convenience only and do not in any manner serve as an endorsement of those Web sites. The materials at those Web sites are not part of the materials for this IBM® product and use of those Web sites is at your own risk.

HCL® may use or distribute any of the information you supply in any way it believes appropriate without incurring any obligation to you.

Licensees of this program who wish to have information about it for the purpose of enabling: (i) the exchange of information between independently created programs and other programs (including this one) and (ii) the mutual use of the information which has been exchanged, should contact:

IBM® Corporation  
2Z4A/101  
11400 Burnet Road  
Austin, TX 78758  
U.S.A.

Such information may be available, subject to appropriate terms and conditions, including in some cases, payment of a fee.

The licensed program described in this document and all licensed material available for it are provided by HCL® under terms of the HCL® Customer Agreement, HCL® International Program License Agreement or any equivalent agreement between us.

Any performance data contained herein was determined in a controlled environment. Therefore, the results obtained in other operating environments may vary significantly. Some measurements may have been made on development-level systems and there is no guarantee that these measurements will be the same on generally available systems. Furthermore, some measurements may have been estimated through extrapolation. Actual results may vary. Users of this document should verify the applicable data for their specific environment.

Information concerning non-HCL products was obtained from the suppliers of those products, their published announcements or other publicly available sources. HCL® has not tested those products and cannot confirm the accuracy of performance, compatibility or any other claims related to non-HCL products. Questions on the capabilities of non-HCL products should be addressed to the suppliers of those products.

This information contains examples of data and reports used in daily business operations. To illustrate them as completely as possible, the examples include the names of individuals, companies, brands, and products. All of these names are fictitious and any similarity to the names and addresses used by an actual business enterprise is entirely coincidental.

## **Copyright License**

This information contains sample application programs in source language, which illustrate programming techniques on various operating platforms. You may copy, modify, and distribute these sample programs in any form without payment to HCL, for the purposes of developing, using, marketing or distributing application programs conforming to the application programming interface for the operating platform for which the sample programs are written. These examples have not been thoroughly tested under all conditions. HCL, therefore, cannot guarantee or imply reliability, serviceability, or function of these

programs. The sample programs are provided "AS IS", without warranty of any kind. HCL shall not be liable for any damages arising out of your use of the sample programs.

# Index

## A

- aggregating usage and discovery data 124
  - TPARAM parameters 124
- Aggregator
  - aggregating usage and discovery data 124
- Analyzer
  - overview 7
- Analyzer online mode navigation 153
- APF 22
- Automation Server
  - control data set 127
  - excluding data sets 134
  - required files 127
  - running 127
  - starting 133
  - stopping 133

## C

- CAP - Set hardware capacity collection status 95
- CICS
  - monitoring usage 118
- commands
  - reading syntax diagrams 9
- commands, Usage Monitor 94
- customizing a CICS region to provide usage data 119

## D

- D-A - Display output allocation parameters 96
- D-C - Display the counters and statistics 97
- D-D - Display the data set name inclusion and exclusion lists 97
- D-I - Display the system identifier 97
- D-S - Display the status settings 98
- D-T - Display the automatic switch-and-write time setting 98
- D-X - Display the active exclude list 98
- data sets, scanning generation 78
- database changes since the product was released
  - verifying 182, 184, 184
- databases
  - Inquisitor requests 75
- Db2 authorization 22
- DCB - Set output DCB attributes 98
- DEL - Deleting program mask entries 99
- deployment
  - Inquisitor data 17
  - Repository 18
  - Usage event 18
- DFHSM Integration 77
- DSN
  - Usage Monitor command 100
- DUR
  - Usage Monitor command 101

## E

- examples, Inquisitor for z/OS 72

- EXC - Adding program mask exclusion entries 101
- exclusion masks 88

## F

- filtering program names 88
- fragments, syntax diagrams 9

## G

- generation data sets, scanning 78

## H

- HSIC, Operation messages 251
- HSII REXX utility messages 279
- HSIP, Inquisitor for
  - Db2
- messages
  - 293
- HSISIVPD
  - job in the JCLLIB that verifies database changes since the product was released 182, 184, 184
- HSIT - Product Tagging messages 329
- HSIX, Inquisitor messages 340
- HSIXOMIT
  - 83
- HSIXROOT
  - 83
- HSIZ, Usage Monitor messages 344

## I

- IDD - Deleting data set name inclusion entries 103
- IDS - Adding data set name inclusion entries 103
- Import Usage
  - TPARAM parameters 123
- initial space allocation
  - performance and tuning 230
- Inquisitor
  - overview 6
  - scanning generation data sets 78
- Inquisitor data
  - description 17
- Inquisitor for
  - Db2
  - , HSIP
  - 293
- Inquisitor for z/OS
  - examples 72
  - TPARAM parameters 121
- Inquisitor Import
  - overview 7
- Inquisitor Import, running 61, 120
- Inquisitor messages, HSIC 340
- Inquisitor program
  - SYSIN commands 65
- Inquisitor requests, designing 75
- integration with DFHSM 77

## J

- JAC - Set job account collection status 104
- JNM - Control the collection of job names 105

## K

- keywords, syntax diagrams 9

## L

- LE compile unit information 76
- libraries, scanning migrated 76
- LNK - Set linklist library collection status 106
- LPA - Set link pack area program monitoring status 107

## M

- messages, HSIC 251
- messages, HSII 279
- messages, HSIP 293
- messages, HSIT 329
- messages, HSIX 340
- messages, HSIZ 344
- monitoring usage in CICS regions 118

## N

- navigation, Analyzer online mode 153
- Non-DB application
  - Inquisitor requests 75
- notices ccclxxxvii

## O

- online mode navigation, Analyzer 153
- Operation messages, HSIC 251

## P

- performance and tuning 230, 232
- PRI - Set the data set space primary allocation 109
- process flow 7
- Product Tagging, HSIT 329
- program names, filtering 88
- PRS - Set registered software activity data collection status 110

## R

- RACF customization 22
- REF - Refresh Usage Monitor settings 111
- repeatable items, syntax diagrams 9
- Repository
  - description 18
  - overview 7
- Repository table layouts 192
- REXX utility messages, HSII 279

## S

- SEC - Set the data set space secondary allocation 111
- security, z/OS UNIX 22
- SID - Set the Usage Monitor system identifier 112
- syntax diagrams, how to read 9
- system platform
  - Inquisitor requests 75

## T

- table layouts, Repository 192
- trademarks ccclxxvii
- troubleshooting
  - identifying problems 238
  - systematic problem solving 238
- TSO
  - Inquisitor requests 75

## U

- UNIX security, z/OS 22
- usage
  - monitoring in CICS regions 118
- usage and discovery data
  - aggregating 124
- usage data
  - customizing a CICS region 119
- usage event
  - description 18
- Usage Import
  - overview 7
- Usage Monitor
  - overview 7
  - running 93
- Usage Monitor command
  - CAP - Set hardware capacity collection status 95
  - CIC – Allow or disable program usage data from CICS regions 96
  - D-A - Display output allocation parameters 96
  - D-C - Display the counters and statistics 97
  - D-D - Display the data set name inclusion and exclusion lists 97
  - D-I - Display the system identifier 97
  - D-S - Display the status settings 98
  - D-T - Display the automatic switch-and-write time setting 98
  - D-X - Display the active exclude list 98
  - DCB - Set output DCB attributes 98
  - DEL - Deleting program mask entries 99
  - DSN - Setting the data set name prefix 100
  - DUR - Set execution duration 101
  - EXC - Adding program mask exclusion entries 101
  - IDD - Deleting data set name inclusion entries 103
  - IDS - Adding data set name inclusion entries 103
  - JAC - Set job account collection status 104
  - JID - Control the preservation of batch job identifiers 105
  - JIPH – Control collection of TCP/IP Host details 104
  - JNM - Control the collection of job names 105
  - LDI – Set LOAD exclusion inactive 106
  - LDX – Add or activate a LOAD exclusion 106
  - LNK - Set linklist library collection status 106
  - LPA - Set link pack area program monitoring status 107
  - LPLN - Set the sysplex name 109
  - PRE - Collect usage for long running programs 109
  - PRI - Set the data set space primary allocation 109
  - PRS - Set registered software activity data collection status 110

- QSZ – Specify collection element queue area size 110
- REF - Refresh Usage Monitor settings 111
- SEC - Set the data set space secondary allocation 111
- SID - Set the Usage Monitor system identifier 112
- SIZ - Set the data space repository size 112
- SJS - Controlling spawned job suffix preservation 113
- SWI - Switch to a new data space repository 113
- UID - Control the collection of user details 114
- UNK - Set the unknown event collection switch 114
- UNM - Set user name collection status 115
- UNT - Set the data set allocation unit 115
- USS - Set UNIX program monitoring status 116
- VOL - Set the data set allocation volume 116
- WRT- Set the automatic switch-and-write time of day 116
- XDD - Deleting data set name exclusion entries 117
- XDS - Adding data set name exclusion entries 117
- ZIP - Set the compressed output data switch 118

- Usage Monitor commands 94
- Usage Monitor messages, HSIZ 344

## V

- variables, syntax diagrams 9
- verifying database changes since the product was released 182, 184, 184

## W

- work pool
  - Inquisitor requests 75

## X

- XVOLUME 68

## Z

- z/OS UNIX security 22