

**IBM® Z Workload Scheduler**  
**Scheduling End-to-end with z-centric Capabilities**  
**Version 10.2**

## Note

Before using this information and the product it supports, read the information in [Notices on page clxxv](#).

This edition applies to version 10, release 2, modification level 0 of IBM® Z Workload Scheduler (program number 5698-T09) and to all subsequent releases and modifications until otherwise indicated in new editions.

# Contents

List of Figures.....	vi
List of Tables.....	vii
About this publication.....	viii
What is new in this release.....	viii
Who should read this publication.....	viii
Accessibility .....	viii
Technical training.....	viii
Support information.....	ix
Conventions.....	ix
How to read syntax diagrams.....	ix
<b>Chapter 1. Configuring.....</b>	<b>13</b>
Overview.....	13
Advantages of job types with advanced options.....	17
Configuring the agent.....	18
Configuring proxy properties [ITA_Env].....	21
Configuring log message properties [JobManager.Logging.ccllog].....	22
Configuring trace properties when the agent is stopped [JobManager.Logging.ccllog].....	23
Trace configuration for the agent.....	25
Configuring common launchers properties [Launchers].....	28
Configuring properties of the native job launcher [NativeJobLauncher].....	30
Configuring properties of the Java™ job launcher [JavaJobLauncher].....	33
Configuring properties of the Resource advisor agent [ResourceAdvisorAgent].....	34
Configuring properties of the System scanner [SystemScanner].....	36
Configuring properties of event-driven workload automation [EventDrivenWorkload].....	36
Regular agent maintenance.....	37
Configuring Z controller.....	38
Defining destinations with the ROUTOPTS statement.....	39
<b>Chapter 2. Customizing the HTTP connections .....</b>	<b>41</b>
Customizing HTTP connection with HTTPOPTS statement.....	41
Customizing the http timeout on the Dynamic Workload Console.....	41
Configuring the heartbeat checking interval for z-centric agents and dynamic domain managers.....	42
Configuring the connection between the z-centric agent and controller through a proxy.....	42
Starting and stopping HTTP subtasks.....	43
<b>Chapter 3. Defining user IDs and passwords with the USRREC statement.....</b>	<b>45</b>
USRREC.....	45
<b>Chapter 4. Defining variables and passwords for local resolution.....</b>	<b>48</b>
Creating and managing variables and passwords on the agents.....	48
Specifying variables and passwords in the JOBREC statement.....	51
Specifying local variables and passwords in job types with advanced options.....	52
<b>Chapter 5. Defining and managing IBM Z Workload Scheduler Agent workstations in the database.....</b>	<b>54</b>
Creating.....	54
Modifying.....	55
Browsing.....	55
Deleting.....	56
Listing.....	56
Managing the status of the workstation in the plan.....	56
Automatic and manual changes to the status of IBM Z Workload Scheduler Agent workstation.....	57
WSSTAT.....	58
Browsing system information of IBM Z Workload Scheduler Agent workstations.....	61
<b>Chapter 6. Defining and managing dynamic workstations.....</b>	<b>62</b>
Creating broker workstations.....	63
Defining a backup dynamic domain manager.....	64
Creating pools and dynamic pools.....	65
Submitting jobs to pools or dynamic pools.....	65
Submitting jobs by reference.....	66
<b>Chapter 7. Setting the security features.....</b>	<b>67</b>
Customizing the SSL connection with the Z controller when using your certificates (SAF).....	67
Customizing the SSL connection with the Z controller when using your certificates (USS).....	70
Enabling FIPS compliance over IBM Z Workload Scheduler server SSL secured connection.....	71
Encrypting the user password.....	72
<b>Chapter 8. Defining and managing jobs.....</b>	<b>73</b>
Defining jobs from the Dynamic Workload Console.....	73
Defining a job in the JOBLIB data set.....	73
JOBREC.....	74
Syntax diagram for database job types.....	76
Syntax diagram for file transfer job types.....	84
Syntax diagram for web service job types.....	90
Syntax diagram for Java job type.....	92
Syntax diagram for xajob job type.....	94
Syntax diagram for J2EE jms job type.....	96
Syntax diagram for native job type.....	98

Using variable substitution.....	102	Activating and configuring Output collector.....	154
Defining file dependencies to check for file changes.....	102	Refreshing destinations from Output collector.....	155
Maintaining the filewatch log database.....	105	<b>Chapter 13. Troubleshooting.....</b>	<b>157</b>
Checking for file changes with filemonitor.....	106	On AIX operating systems the concurrent submission of one hundred or more jobs on the same agent can result in a core dump or in a resource temporarily unavailable message.....	157
Promoting critical jobs.....	112	<b>Appendix A. Configure to schedule job types with advanced options.....</b>	<b>158</b>
Killing operations.....	112	Logs for job types with advanced options.....	158
ISPF.....	113	<b>Appendix B. Managing return codes.....</b>	<b>160</b>
PIF.....	113	<b>Appendix C. Modifying the workstation from fault-tolerant agent to z-centric agent.....</b>	<b>162</b>
BCIT.....	113	<b>Appendix D. Defining access methods for agents.....</b>	<b>164</b>
OCL.....	113	Access method interface.....	165
Dynamic Workload Console.....	114	Method command line syntax.....	165
<b>Chapter 9. Administering IBM i dynamic environment... 115</b>		Method response messages.....	167
Scheduling on IBM i.....	115	Method options file.....	168
The agent joblog and TWSASPOOLS environment variable.....	116	Running methods.....	171
Child job monitoring on IBM i agents.....	116	Launch job task (LJ).....	171
The agent return code retrieval.....	120	Manage job task (MJ).....	172
Controlling the job environment with the user return code.....	120	<b>Appendix E. Collecting job metrics.....</b>	<b>174</b>
Alternative method to set the user return code.....	121	Job metrics queries for DB2 for zOS.....	174
Configuring the agent on IBM i systems.....	122	Job metrics queries for DB2.....	174
Configuring log message properties [JobManager.Logging.ccllog].....	123	Notices.....	clxxv
Configuring trace properties when the agent is stopped [JobManager.Logging.ccllog].....	125	Index.....	179
Trace configuration for the agent.....	126		
Configuring common launchers properties [Launchers].....	129		
Configuring properties of the native job launcher [NativeJobLauncher].....	131		
Configuring properties of the Java™ job launcher [JavaJobLauncher].....	134		
Configuring properties of the Resource advisor agent [ResourceAdvisorAgent].....	135		
Configuring properties of the System scanner [SystemScanner].....	137		
Configuring to schedule job types with advanced options.....	138		
Customizing the SSL connection between IBM i agents and the Z controller when using your certificates.....	139		
<b>Chapter 10. Monitoring and recovering jobs..... 141</b>			
Job status notifications.....	141		
Setting up and running automatic recovery for jobs.....	141		
Automatic-recover-control statement for IBM Z Workload Scheduler Agent scripts.....	142		
<b>Chapter 11. Running a script when a job completes..... 149</b>			
<b>Chapter 12. Viewing the job logs from the host..... 150</b>			
Customizing the job log header.....	150		
Collecting job logs with Output collector.....	152		

# List of Figures

Figure 1: Static end-to-end environment with Java™ run time installed in which you can run job types with advanced options..... 13

Figure 2: Dynamic end-to-end environment to run also job types with advanced options..... 14

Figure 3: Process flow..... 15

Figure 4: EQQWCGEP - Creating general information about an IBM Z Workload Scheduler Agent workstation.....54

Figure 5: EQQWMGEP - Modifying an IBM Z Workload Scheduler Agent workstation description..... 55

Figure 6: EQQWBGEP - Browsing an IBM Z Workload Scheduler Agent workstation description..... 55

Figure 7: EQQWDGEP - Deleting an IBM Z Workload Scheduler Agent workstation description..... 56

Figure 8: EQQWWSEP - Specifying list selection criteria for IBM Z Workload Scheduler Agent workstations..... 56

Figure 9: EQQSWIZC - Browsing an IBM Z Workload Scheduler Agent workstation system information..... 61

Figure 10: EQQWCGEP - Creating general information about a broker workstation..... 64

Figure 11: EQQWCEOD - Defining end-to-end options..... 64

Figure 12: Job log retrieval with Output collector..... 153

## List of Tables

Table 1: Installation and configuration steps for setting up an end-to-end with z-centric capabilities environment.....	16
Table 2: Agent configuration parameters.....	38
Table 3: Jobs and their keywords.....	75
Table 4: Configuration files for job types with advanced options.....	138
Table 5: Job status change notifications.....	141
Table 6: The predefined variables of the sample job log header template.....	151
Table 7: Configuration files for job types with advanced options.....	158
Table 8: Method command task options.....	166
Table 9: Launch job task (LJ) messages.....	172

## About this publication

*Scheduling End-to-end with z-centric Capabilities* describes how to set up IBM® Z Workload Scheduler to generate a lightweight end-to-end scheduling environment in which to schedule and control workload from the mainframe to distributed systems. While it exhaustively describes the required installation and customization tasks, this first edition provides only miscellaneous notes about the z-centric end-to-end scheduling solution. This publication is therefore to be used in conjunction with the rest of the IBM Workload Automation library; in particular see the following publications:

- *Customization and Tuning* for information about customizing and tuning IBM Z Workload Scheduler.
- *Managing the Workload* for details about organizing your workload and information about managing the workload when it becomes part of a plan and is run.
- *Messages and Codes* for message information.
- *IBM Z Workload Scheduler: Planning and Installation* for details about how to install the IBM Z Workload Scheduler Agent.
- *Memo to Users* for interoperability information among component versions.

## What is new in this release

Learn what is new in this release.

For information about the new or changed functions in this release, see the section *Summary of enhancements* in the *Overview* manual.

For information about the APARs that this release addresses, see the *IBM Z Workload Scheduler: Program Directory* and the *Dynamic Workload Console Release Notes*.

## Who should read this publication

This publication is intended for IBM Z Workload Scheduler users who are already familiar with IBM Workload Scheduler. A background knowledge of IBM Z Workload Scheduler is required.

## Accessibility

Accessibility features help users with a physical disability, such as restricted mobility or limited vision, to use software products successfully.

With this product, you can use assistive technologies to hear and navigate the interface. You can also use the keyboard instead of the mouse to operate all features of the graphical user interface.

For full information, see the Accessibility Appendix in the *IBM Workload Scheduler User's Guide and Reference*.

## Technical training

Cloud & Smarter Infrastructure provides technical training.

For Cloud & Smarter Infrastructure technical training information, see: <http://www.ibm.com/software/tivoli/education>



## Support information

IBM provides several ways for you to obtain support when you encounter a problem.

If you have a problem with your IBM software, you want to resolve it quickly. IBM provides the following ways for you to obtain the support you need:

- Searching knowledge bases: You can search across a large collection of known problems and workarounds, Technotes, and other information.
- Obtaining fixes: You can locate the latest fixes that are already available for your product.
- Contacting IBM Software Support: If you still cannot solve your problem, and you need to work with someone from IBM, you can use a variety of ways to contact IBM Software Support.

For more information about these three ways of resolving problems, see the appendix about support information in *IBM Workload Scheduler: Troubleshooting Guide*.

## Conventions used in this publication

Conventions used in this publication.

The publication uses several typeface conventions for special terms and actions. Technical changes to the text are indicated by a vertical line to the left of the change. These conventions have the following meanings:

Information type	Style convention	Example
Commands	All capital letters	CREATE
References in the text to fields on panels	All capital letters	QUANTITY
File and directory names, input you should type in panel fields	Monospace	MYAPPLICATION
First time new term introduced, publication titles	Italics	<i>Application</i>

## How to read syntax diagrams

Syntax diagrams help to show syntax in a graphical way.

Throughout this publication, syntax is described in diagrams like the one shown here, which describes the SRSTAT TSO command:

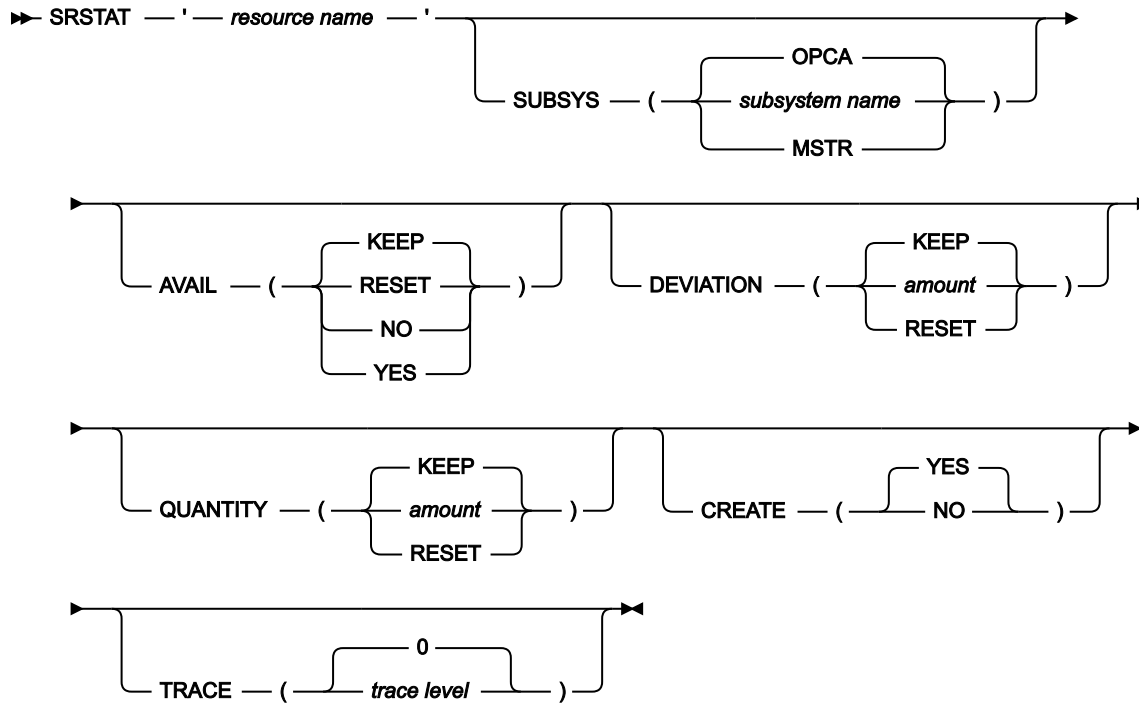

The symbols have these meanings:



The statement begins here.



The statement is continued on the next line.

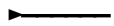

The statement is continued from a previous line.



The statement ends here.

Read the syntax diagrams from left to right and from top to bottom, following the path of the line.

These are the conventions used in the diagrams:

- Required items appear on the horizontal line (main path):

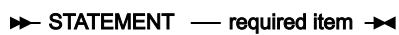

- Optional items appear below the main path:

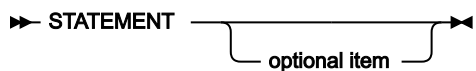

- An arrow returning to the left above the item indicates an item that you can repeat. If a separator is required between items, it is shown on the repeat arrow.

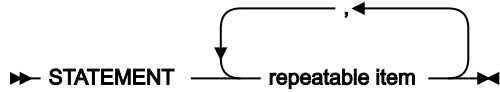

- If you can choose from two or more items, they appear vertically in a stack.
  - If you must choose one of the items, one item of the stack appears on the main path:

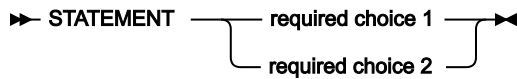

- If choosing one of the items is optional, the entire stack appears below the main path:

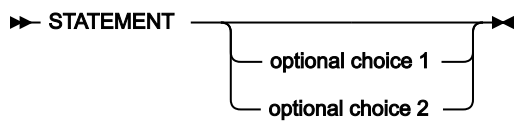

- A repeat arrow above a stack indicates that you can make more than one choice from the stacked items:

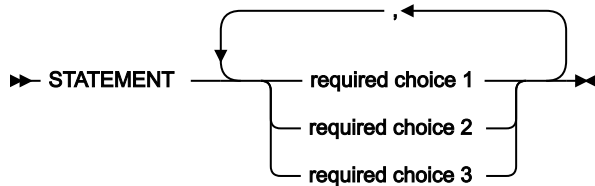
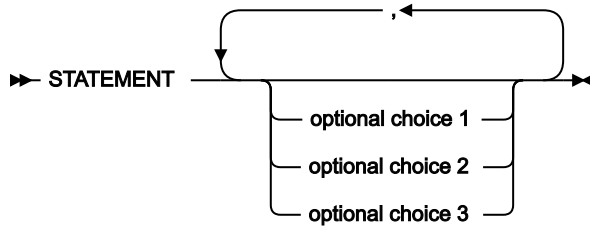

- Parameters that are above the main line are default parameters:

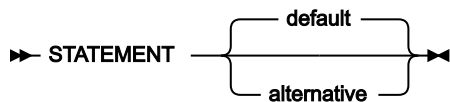

- Keywords appear in uppercase (for example, STATEMENT).
- Parentheses and commas must be entered as part of the command syntax, as shown.

- For complex commands, the item attributes might not fit on one horizontal line. If that line cannot be split, the attributes appear at the bottom of the syntax diagram:

► STATEMENT ►

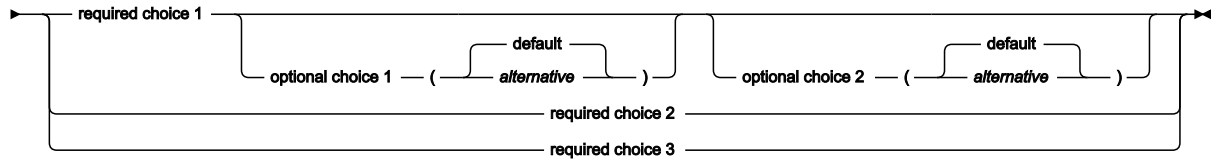

# Chapter 1. Configuring

This chapter provides a general description of the end-to-end with z-centric capabilities environment and describes the configuration steps required to make it work.

## Overview

The different types of workload scheduling you can implement in your z-centric end-to-end environment:

### Static scheduling

The IBM Z Workload Scheduler Agents are installed on the distributed systems and are connected to the z/OS® system through the IBM Z Workload Scheduler controller.

### Static scheduling including job types with advanced options

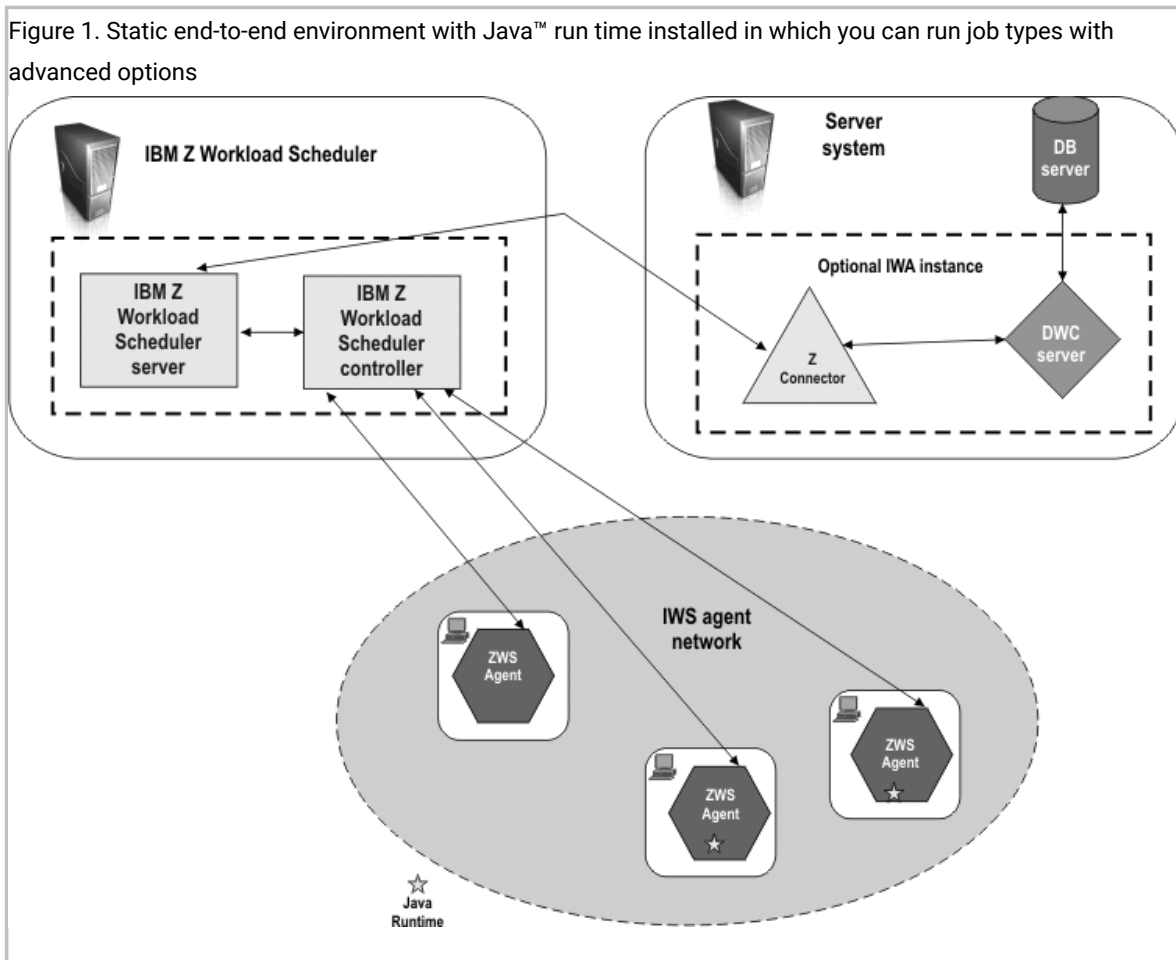

The IBM Z Workload Scheduler Agents are installed on the distributed systems with the Java™ run time, and are connected to the z/OS® system through the IBM Z Workload Scheduler controller. [Figure 1: Static end-to-end environment with Java run time installed in which you can run job types with advanced options on page 13](#) shows a **static** end-to-end environment in which IBM Z Workload Scheduler Agents:

- Without the Java™ run time installed, can run existing job types
- With the Java™ run time installed, can run both existing jobs and job types with advanced options

**Dynamic scheduling**

The IBM Z Workload Scheduler Agents are installed on the distributed systems with dynamic capabilities, and are connected to the dynamic domain manager. The dynamic domain manager is connected to the z/OS® system through the IBM Z Workload Scheduler controller.

**Dynamic scheduling including job types with advanced options**

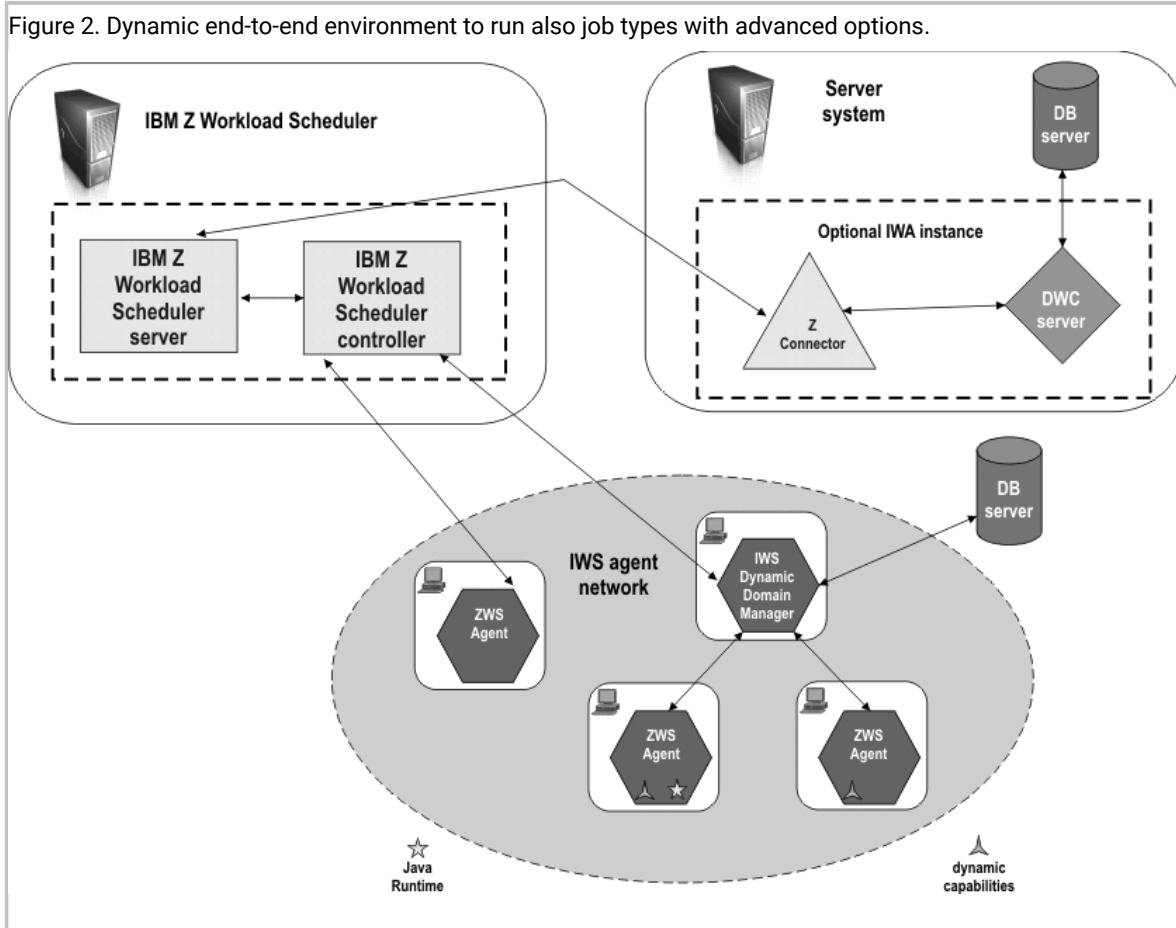

The IBM Z Workload Scheduler Agents are installed on the distributed systems with dynamic capabilities and the Java™ run time, and are connected to the dynamic domain manager. The dynamic domain manager is connected to the z/OS® system through the IBM Z Workload Scheduler controller. [Figure 2: Dynamic end-to-end environment to run also job types with advanced options. on page 14](#) shows a **dynamic** end-to-end environment in which IBM Z Workload Scheduler Agents:

- Without the Java™ run time installed, can run existing job types
- With the Java™ run time installed, can run both existing jobs and job types with advanced options

By using the z-centric end-to-end scheduling environment, you schedule and control both static and dynamic workload from the mainframe to distributed systems with a low cost of ownership. IBM Z Workload Scheduler acts as a single point of control, providing you with all the mainframe capabilities to manage distributed workload.

IBM Z Workload Scheduler Agents can be installed on the UNIX™, IBM® i, or Windows™ workstations where you run jobs scheduled from IBM Z Workload Scheduler. After installation, you associate each agent to an IBM Z Workload Scheduler workstation definition, so that it can be used as a target for IBM Z Workload Scheduler jobs. The communication between the IBM Z Workload Scheduler Agent and IBM Z Workload Scheduler controller is direct, through the HTTP or HTTPS protocol. If the connection is interrupted, the HTTP client retries to establish it until it is successful.

Figure 3: Process flow on page 15 shows the process flow to submit and track jobs on IBM Z Workload Scheduler Agent workstations.

Figure 3. Process flow

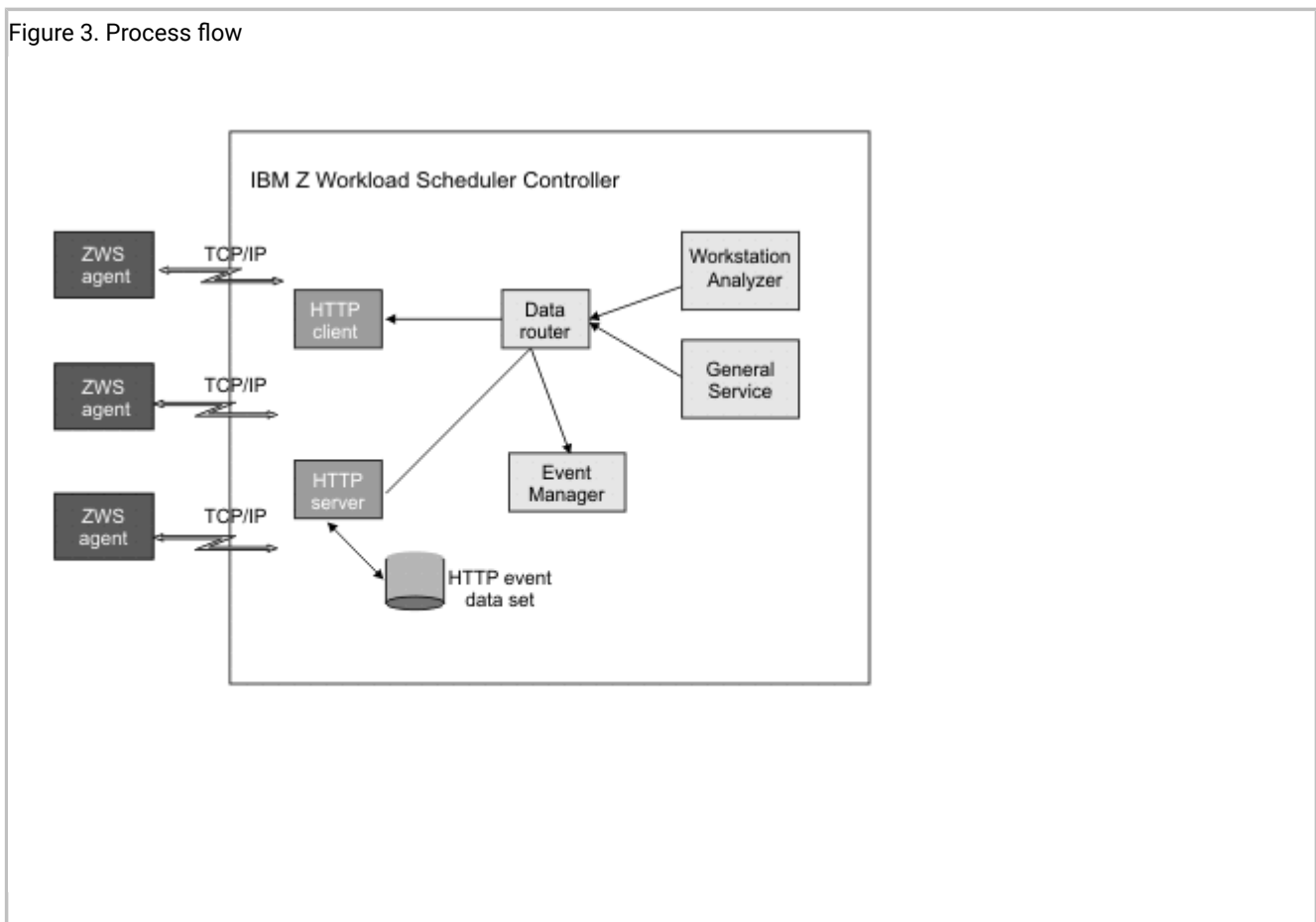

Table 1: Installation and configuration steps for setting up an end-to-end with z-centric capabilities environment on page 16 shows the steps required to set up your end-to-end with z-centric capabilities environment.

**Table 1. Installation and configuration steps for setting up an end-to-end with z-centric capabilities environment**

To...	Refer to...
Plan your end-to-end environment with z-centric capabilities and install the IBM Z Workload Scheduler Agent.	<i>IBM Z Workload Scheduler: Planning and Installation</i>
Install the dynamic domain manager and agent.	<i>IBM Workload Scheduler: Planning and Installation</i>
Configure the IBM Z Workload Scheduler Agent properties.	<a href="#">Configuring the IBM Z Workload Scheduler Agent settings on page 16</a>
Define the IBM Z Workload Scheduler Agent and dynamic domain manager destinations.	<a href="#">Defining destinations with the ROUTOPTS statement on page 39</a>
Define the IBM Z Workload Scheduler Agent workstations.	<a href="#">Defining and managing IBM Z Workload Scheduler Agent workstations in the database on page 54</a>
Define dynamic workstations.	<a href="#">Defining and managing dynamic workstations on page 62</a>
Configure the SSL connection protocol, if you did not change the default configuration of the IBM Z Workload Scheduler Agent.	<a href="#">Setting the security features on page 67</a>
Customize the connection parameters.	<a href="#">Customizing the HTTP connection with the HTTPOPTS statement on page 41</a>

## Configuring the IBM Z Workload Scheduler Agent settings

The configuration settings of the IBM Z Workload Scheduler Agent are contained in the `JobManager.ini` file.

The file is made up of many different sections. Each section name is enclosed between square brackets and each section includes a sequence of `variable = value` statements.

You can customize properties for the following:

- Log and trace
- Native job executor
- Java™ job executor

Not all the properties in the `JobManager.ini` file can be customized. For a list of the configurable properties, see the tables in the following sections.



## Advantages of job types with advanced options

While the existing IBM® Z Workload Scheduler job is a generic script or command, you can define and schedule job types with advanced options to perform specific tasks, such as database, file transfer, Java™, and web services operations. You can easily define these job types without having specific skills on the applications where the job runs.

The job types with advanced options include both those supplied with the product and the additional types implemented through the custom plug-ins.

Besides, you can deploy or update a plug-in from Automation Hub at the following link: [Automation Hub](#).

The following job types with advanced options are available:

### **File transfer jobs**

Transfer files to and from a server reachable using FTP, SSH, or other protocols.

### **Web services jobs**

Call a web service.

### **Database jobs**

Perform queries, SQL statements, and jobs on a number of databases, including custom databases. You can also create and run stored procedures on DB2, Oracle, and MSSQL databases.

### **Executable jobs**

Run a script or command with advanced options, such as redirecting standard input and standard output to a file.

### **Java jobs**

Run a Java class

### **MSSQL jobs**

Run a Microsoft SQL job.

### **Access Method jobs**

Extend job scheduling functions of IBM Workload Scheduler to other systems and applications using access methods. The access methods communicate with the external system to launch the job and return the status of the job. The following access methods are available:

- Oracle E-Business Suite
- PeopleSoft
- SAP
- MVS
- Custom methods

### **J2EE jobs**

Allow Java applications in the same network to send and receive messages from and to a JMS destination.

### IBM i jobs

Run a command on IBM i systems.

### Provisioning

Jobs that span physical computers, virtual machines, and private and public cloud environments creating an on-demand environment. This job type integrates with IBM SmartCloud Provisioning.

### Remote command

Jobs that can run on remote computers that do not require an agent installation.

You define job types with advanced options by connecting to a z/OS® engine with the Dynamic Workload Console. From the Dynamic Workload Console, you open the Workload Designer and select the job type you want to create. When the job definition is saved, it is stored in the JCL library and is available for scheduling from IBM® Z Workload Scheduler

The job types with advanced options run on IBM Z Workload Scheduler Agents in both the static configuration (IBM Z Workload Scheduler Agent connected directly to the Z controller) and in the dynamic configuration (IBM Z Workload Scheduler Agent connected to the dynamic domain manager).

In addition to configuring job types with advanced options using the Dynamic Workload Console, you can use the related configuration files. For more information, see [Configuring to schedule job types with advanced options on page 158](#).

For the procedure about defining job types with advanced options, see the section about creating job types with advanced options in *Dynamic Workload Console User's Guide*.

For details about each job type, see the Dynamic Workload Console online help. For details about how to create jobs using the JOBREC statement, see [JOBREC on page 74](#).

You can create custom plug-ins to implement your own job types with advanced options for applications not supported by IBM Workload Scheduler. For information about how to create custom plug-ins, see *Extending IBM Workload Automation, SC14-7623*.

The agents with dynamic capabilities can run the jobs you created for the existing IBM Workload Scheduler workstation types. To run these jobs on the dynamic agents, you only have to change the specification of the workstation where you want the job to run. The major advantage is that you can use the workflows you previously created without additional effort.

## Configuring the agent

The configuration settings of the agent are stored in the `JobManager.ini` file.

In a distributed environment, if a gateway is configured to allow the master domain manager or dynamic domain manager to communicate with a dynamic agent located behind a network boundary, then the gateway configuration settings of the agent are contained in the `JobManagerGW.ini` file. This file is almost identical to the `JobManager.ini` file, however, only parameters in the [ITA], [Env], and [ResourceAdvisorAgent] sections require configuration. For these parameters, definitions are given for both the `JobManager.ini` and `JobManagerGW.ini` files.

To find out where these files are located, see the section about installation paths in *IBM Workload Scheduler: Planning and Installation*.

Only a subset of the available parameters is documented, because some parameters are reserved for internal use.

These files are made up of many different sections. Each section name is enclosed between square brackets and each section includes a sequence of `variable = value` statements.

You can customize properties for the following:

- Event-driven workload automation properties
- Log properties
- Trace properties when the agent is stopped. You can also customize traces when the agent is running using the procedure described in [Configuring trace properties when the agent is running on page 25](#).
- Native job executor
- Java™ job executor
- Resource advisor agent
- System scanner

The log messages are written in the following file:

**On Windows operating systems:**

`<TWA_home>\TWS\stdlist\JM\JobManager_message.log`

**On UNIX and Linux operating systems:**

`<TWA_DATA_DIR>/stdlist/JM/JobManager_message.log`

The trace messages are written in the following file:

**On Windows operating systems:**

- `<TWA_home>\TWS\stdlist\JM\ITA_trace.log`
- `<TWA_home>\TWS\stdlist\JM\JobManager_trace.log`
- `<TWA_home>\TWS\JavaExt\logs\javaExecutor0.log`

**On UNIX and Linux operating systems:**

- `<TWA_DATA_DIR>/stdlist/JM/ITA_trace.log`
- `<TWA_DATA_DIR>/stdlist/JM/JobManager_trace.log`
- `<TWA_DATA_DIR>/JavaExt/logs/javaExecutor0.log`

**Logging information about job types with advanced options**

You can use the `logging.properties` file to configure the logging process for job types with advanced options, with the exception of the Executable and Access Method job types.

The `logging.properties` file is located on the IBM® Z Workload Scheduler Agent, located in the following path:

**On Windows operating systems:**

<TWA\_home>/TWS/JavaExt/cfg/logging.properties

**On UNIX and Linux operating systems:**

<TWA\_DATA\_DIR>/JavaExt/cfg/logging.properties

After installation, this file is as follows:

```
# Specify the handlers to create in the root logger
# (all loggers are children of the root logger)
# The following creates two handlers
handlers = java.util.logging.ConsoleHandler,
           java.util.logging.FileHandler

# Set the default logging level for the root logger
.level = INFO

# Set the default logging level for new ConsoleHandler instances
java.util.logging.ConsoleHandler.level = INFO

# Set the default logging level for new FileHandler instances
java.util.logging.FileHandler.level
    = ALL
java.util.logging.FileHandler.pattern
    = C:\TWA_home\TWS\JavaExt\logs\javaExecutor%g.log
java.util.logging.FileHandler.limit
    = 1000000
java.util.logging.FileHandler.count
    = 10

# Set the default formatter for new ConsoleHandler instances
java.util.logging.ConsoleHandler.formatter =
    java.util.logging.SimpleFormatter
java.util.logging.FileHandler.formatter =
    java.util.logging.SimpleFormatter

# Set the default logging level for the logger named com.mycompany
com.ibm.scheduling = INFO
```

You can customize:

- The logging level (from INFO to WARNING, ERROR, or ALL) in the following keywords:

**.level**

Defines the logging level for the internal logger.

**com.ibm.scheduling**

Defines the logging level for the job types with advanced options. To log information about job types with advanced options, set this keyword to ALL.

- The path where the logs are written, specified by the following keyword:

```
java.util.logging.FileHandler.pattern
```

Not all the properties in the `JobManager.ini` and `JobManagerGW.ini` files can be customized. For a list of the configurable properties, see the following sections:

- [Configuring log message properties \[JobManager.Logging.ccllog\] on page 22](#)
- [Configuring trace properties when the agent is stopped \[JobManager.Logging.ccllog\] on page 23.](#)
- [Configuring common launchers properties \[Launchers\] on page 28](#)
- [Configuring properties of the native job launcher \[NativeJobLauncher\] on page 30.](#)
- [Configuring properties of the Java job launcher \[JavaJobLauncher\] on page 33.](#)
- [Configuring properties of the Resource advisor agent \[ResourceAdvisorAgent\] on page 34.](#)
- [Configuring properties of the System scanner \[SystemScanner\] on page 36](#)
- [Configuring environment variables \[Env\]](#)
- The section about configuring properties of event-driven workload automation [EventDrivenWorkload] in *IBM Z Workload Scheduler: Scheduling End-to-end with z-centric Capabilities*

## Configuring proxy properties [ITA\_Env]

### About this task

To have the IBM Z Workload Scheduler Agent communicate with the Z controller through a proxy, edit the `[ITA_Env]` section in the `JobManager.ini` file as follows.



**Note:** On the controller, ensure that you have set the PROXY keyword in the ROUTOPTS statement.

Depending on the type of connection you are using, add or modify the following property:

#### SSL-secured connection

##### https\_proxy

The URL of the proxy through which the agent communicates to the controller. The value is

```
https_proxy =http://<proxy_wks>:<proxy_wks_port>
```

where:

- `<proxy_wks>` is the fully qualified host name of the workstation where the proxy is configured.
- `<proxy_wks_port>` is the port number of the workstation where the proxy is configured.

#### Non SSL-secured connection

##### http\_proxy

The URL of the proxy through which the agent communicates to the controller. The value is

```
http_proxy =http://<proxy_wks>:<proxy_wks_port>
```

where:

- *<proxy\_wks>* is the fully qualified host name of the workstation where the proxy is configured.
- *<proxy\_wks\_port>* is the port number of the workstation where the proxy is configured.

Restart the agent after the property change.

## Configuring log message properties [JobManager.Logging.cclog]

### About this task

To configure the logs, edit the [JobManager.Logging.cclog] section in the `JobManager.ini` file. This procedure requires that you stop and restart the IBM Workload Scheduler agent

The section containing the log properties is named:

```
[JobManager.Logging.cclog]
```

You can change the following properties:

#### **JobManager.loggerhd.fileName**

The name of the file where messages are to be logged. the default value is

##### **On Windows operating systems**

```
TWA_home\stdlist\JM\JOBMANAGER-FFDC
```

##### **On UNIX operating systems**

```
$(TWA_DATA_DIR)/stdlist/JM/JobManager_message.log
```

#### **JobManager.loggerhd.maxFileBytes**

The maximum size that the log file can reach. The default is **1024000** bytes.

#### **JobManager.loggerhd.maxFiles**

The maximum number of log files that can be stored. The default is **3**.

#### **JobManager.loggerhd.fileEncoding**

By default, log files for the agent are coded in UTF-8 format. If you want to produce the log in a different format, add this property and specify the required codepage.

#### **JobManager.loggerfl.level**

The amount of information to be provided in the logs. The value ranges from 3000 to 7000. Smaller numbers correspond to more detailed logs. The default is **3000**.

#### **JobManager.ffdc.maxDiskSpace**

Exceeding this maximum disk space, log files collected by the first failure data capture mechanism are removed, beginning with the oldest files first.

**JobManager.ffdc.baseDir**

The directory to which log and trace files collected by the ffdc tool are copied. The default directory is

**On Windows operating systems**

```
TWA_home\stdlist\JM\JobManager_message.log
```

**On UNIX operating systems**

```
$(TWA_DATA_DIR)/stdlist/JM/JobManager_message.log
```

**JobManager.ffdc.filesToCopy**

Log and trace files (`JobManager_message.log` and `JobManager_trace.log`) collected by the ffdc tool located in `<TWA_home>\TWS\stdlist\JM`. The files are available in the following paths:

**On Windows operating systems**

- `TWA_home/TWS/stdlist/JM/JobManager_message.log`
- `TWA_home/TWS/stdlist/JM/JobManager_trace.log`

**On UNIX operating systems**

- `$(TWA_DATA_DIR)/stdlist/JM/JobManager_message.log`
- `$(TWA_DATA_DIR)/stdlist/JM/JobManager_trace.log`

When a message is logged (`JobManager.ffdc.triggerFilter = JobManager.msgIdFilter`) that has an ID that matches the pattern "AWSITA\*E" (`JobManager.msgIdFilter.msgIds = AWSITA*E`), which corresponds to all error messages, then the log and trace files (`JobManager.ffdc.filesToCopy = "/opt/IBM/TWA_<TWS_user>/TWS/stdlist/JM/JobManager_message.log" "/opt/IBM/TWA_<TWS_user>/TWS/stdlist/JM/JobManager_trace.log"`) are copied (`JobManager.ffdc.className = ccg_ffdc_filecopy_handler`) to the directory `JOBMANAGER-FFDC` (`JobManager.ffdc.baseDir = /opt/IBM/TWA_<TWS_user>/TWS/stdlist/JM/JOBMANAGER-FFDC`). If the files copied exceed 10 MB (`JobManager.ffdc.maxDiskSpace = 10000000`), then the oldest files are removed first (`JobManager.ffdc.quotaPolicy = QUOTA_AUTODELETE`).

After installing the z-centric agent or dynamic agent on Windows 2012, the `JobManager_message.log` might not be created. In this case, perform the following procedure:

1. Stop the agent.
2. Create a backup copy of `JobManager.ini`, and edit the original file by changing the row:

```
JobManager.loggerhd.className = ccg_multiproc_filehandler
```

to

```
JobManager.loggerhd.className = ccg_filehandler
```

3. Restart the agent.

**Configuring trace properties when the agent is stopped [JobManager.Logging.cclog]**

How to configure the trace properties when the agent is stopped.

To configure the trace properties when the agent is stopped, edit the [JobManager.Logging] section in the `JobManager.ini` file and then restart the IBM Workload Scheduler agent.

The section containing the trace properties is named:

```
[JobManager.Logging.cclog]
```

You can change the following properties:

**JobManager.trhd.fileName**

The name of the trace file. the default path is as follows:

**On Windows operating systems**

```
TWA_home/TWS/stdlist/JM/JobManager_trace.log
```

**On UNIX operating systems**

```
$(TWA_DATA_DIR)/stdlist/JM/JobManager_trace.log
```

**JobManager.trhd.maxFileBytes**

The maximum size that the trace file can reach. The default is 10240000 bytes.

**JobManager.trhd.maxFiles**

The maximum number of trace files that can be stored. The default is 5.

**JobManager.trfl.level**

Determines the type of trace messages that are logged. Change this value to trace more or fewer events, as appropriate, or on request from IBM Software Support. Valid values are:

**DEBUG\_MAX**

Maximum tracing. Every trace message in the code is written to the trace logs.

**INFO**

All *informational*, *warning*, *error* and *critical* trace messages are written to the trace. The default value.

**WARNING**

All *warning*, *error* and *critical* trace messages are written to the trace.

**ERROR**

All *error* and *critical* trace messages are written to the trace.

**CRITICAL**

Only messages which cause the agent to stop are written to the trace.

The output trace (`JobManager_trace.log`) is provided in XML format.

After installing the z-centric agent or dynamic agent on Windows 2012, the `JobManager_trace.log` might not be created. In this case, perform the following procedure:



1. Stop the agent.
2. Create a backup copy of `JobManager.ini`, and edit the original file by changing the row:

```
JobManager.trhd.className = ccg_multiproc_filehandler
```

to

```
JobManager.trhd.className = ccg_filehandler
```

3. Restart the agent.

## Configuring trace properties when the agent is running

Use the **twstrace** command to set the trace on the agent when it is running.

Using the **twstrace** command, you can perform the following actions on the agent when it is running:

- [See command usage and verify version on page 25.](#)
- [Enable or disable trace on page 26.](#)
- Set the traces to a specific level, specify the number of trace files you want to create, and the maximum size of each trace file. See [Set trace information on page 26.](#)
- [Show trace information on page 26.](#)
- Collect trace files, message files, and configuration files in a compressed file using the command line. See [Collect trace information on page 27.](#)
- Collect trace files, message files, and configuration files in a compressed file using the Dynamic Workload Console. See the section about retrieving agent traces from the Dynamic Workload Console in *Troubleshooting Guide*.

You can also configure the traces when the agent is not running by editing the [JobManager.Logging] section in the `JobManager.ini` file as described in [Configuring the agent on page 18](#). This procedure requires that you stop and restart the agent.

## twstrace command

Use the **twstrace** command to configure traces, and collect logs, traces, and configuration files (`ita.ini` and `jobManager.ini`) for agents. You collect all the information in a compressed file when it is running without stopping and restarting it.

### See command usage and verify version

To see the command usage and options, use the following syntax.

#### Syntax

```
twstrace -u | -v
```

#### Parameters

**-u**

Shows the command usage.

**-v**

Shows the command version.

## Enable or disable trace

To set the trace to the maximum or minimum level, use the following syntax.

### Syntax

**twstrace -enable | -disable**

### Parameters

**-enable**

Sets the trace to the maximum level. The maximum level is **1000**.

**-disable**

Sets the trace to the minimum level. The minimum level is **3000**.

## Set trace information

To set the trace to a specific level, specify the number of trace files you want to create, and the maximum size the trace files can reach, use the following syntax.

### Syntax

**twstrace [ -level <level\_number> ] [ -maxFiles <files\_number> ] [ -maxFileBytes <bytes\_number> ]**

### Parameters

**-level <level\_number>**

Sets the trace level. Specify a value in the range from 1000 to 3000, which is also the default value. Note that if you set this parameter to 3000, you have the lowest verbosity level and the fewest trace messages. To have a better trace level, with the most verbose trace messages and the maximum trace level, set it to **1000**.

**-maxFiles <files\_number>**

Specify the number of trace files you want to create.

**-maxFileBytes <bytes\_number>**

Set the maximum size in bytes that the trace files can reach. The default is **1024000** bytes.

## Show trace information

To display the current trace level, the number of trace files, and the maximum size the trace files can reach, use the following syntax.

### Syntax

**twstrace -level | -maxFiles | -maxFileBytes**

## Parameters

### **-level**

See the trace level you set.

### **-maxFiles**

See the number of trace files you create.

### **-maxFileBytes**

See the maximum size you set for each trace file

## Example

### Sample

The example shows the information you receive when you run the following command:

```
twstrace -level -maxFiles -maxFileBytes
```

```
AWSITA176I The trace properties are: level="1000",
max files="3", file size="1024000".
```

## Collect trace information

To collect the trace files, the message files, and the configuration files in a compressed file, use the following syntax.

### Syntax

```
twstrace -getLogs [ -zipFile <compressed_file_name> ] [ -host <host_name> ] [ -protocol {http | https} ] [ -port <port_number> ] [ -iniFile <ini_file_name> ]
```

## Parameters

### **-zipFile <compressed\_file\_name>**

Specify the name of the compressed file that contains all the information, that is logs, traces, and configuration files (ita.ini and jobManager.ini) for the agent. The default is **logs.zip**.

### **-host <host\_name>**

Specify the host name or the IP address of the agent for which you want to collect the trace. The default is **localhost**.

### **-protocol http|https**

Specify the protocol of the agent for which you are collecting the trace. The default is the protocol specified in the **.ini** file of the agent.

### **-port <port\_number>**

Specify the port of the agent. The default is the port number of the agent where you are running the command line.

**-iniFile <ini\_file\_name>**

Specify the name of the **.ini** file that contains the SSL configuration of the agent for which you want to collect the traces. If you are collecting the traces for a remote agent for which you customized the security certificates, you must import the certificate on the local agent and specify the name of the **.ini** file that contains this configuration. To do this, perform the following actions:

1. Extract the certificate from the keystore of the remote agent.
2. Import the certificate in a local agent keystore. You can create an ad hoc keystore whose name must be **TWSSClientKeyStore.kdb**.
3. Create an **.ini** file in which you specify:

- **0** in the **tcp\_port** property as follows:

```
tcp_port=0
```

- The port of the remote agent in the **ssl\_port** property as follows:

```
ssl_port=<ssl_port>
```

- The path to the keystore you created in Step 2 on page 28 in the **key\_repository\_path** property as follows:

```
key_repository_path=<local_agent_keystore_path>
```

## Configuring common launchers properties [Launchers]

### About this task

In the `JobManager.ini` file, the section containing the properties common to the different launchers (or executors) is named:

```
[Launchers]
```

The following properties are available:

#### BaseDir

The installation path of the IBM Workload Scheduler agent. Do not modify this value.

#### CommandHandlerMinThreads

Indicates the maximum number of commands that can be run on the agent concurrently. Limits to the number of jobs vary depending on the resources of your workstation, however consider that operations on comdhandler are usually short. The default is **20**. Usually, there is no need to modify this setting, even if you plan a very high workload on the agent. You might want to change it if many commands are run concurrently on the agent, for example, many concurrent requests to retrieve job logs.

#### CommandHandlerMaxThreads

Indicates the maximum number of commands that can be run on the agent concurrently. Limits to the number of jobs vary depending on the resources of your workstation, however consider that operations on comdhandler are usually short. The default is **100**. Usually, there is no need to modify this setting, even if you plan a very high workload on the agent. You might want to change it if many commands are run concurrently on the agent, for example, many concurrent requests to retrieve job logs.

**CpaHeartBeatTimeSeconds**

The polling interval in seconds used to verify if the **agent** process is still up and running. If the agent process is inactive the product stops also the **JobManager** process. The default is **30**. Modify only if you use dynamic pools with CPU-based requirements or optimization policies. With a lower value, the agent reacts quickly to CPU modifications, but this might cause unstable values in case of CPU spikes. Lower values causes a higher use of resources on the agent.

**DirectoryPermissions**

The access rights assigned to the agent for creating directories when running jobs. The default is **0755**. Supported values are UNIX-format entries in hexadecimal notation.

**DownloadDir**

The name of the directory where the fix pack installation package or upgrade elmage for IBM Workload Scheduler fault-tolerant agents or dynamic agents is downloaded during the centralized agent update process. If not specified, the following default directory is used:

**On Windows operating systems:**

```
TWA_home\TWS\stdlist\JM\download
```

**On UNIX operating systems:**

```
TWA_DATA_DIR/TWS/stdlist/JM/download
```

The centralized agent update process does not apply to z-centric agents.

**ExecutorsMaxThreads**

Specifies the maximum number of jobs the dynamic agent can run concurrently. For example, to allow the dynamic agent to run a maximum of 500 jobs concurrently, set this parameter to **500**. The default is **400**.

**ExecutorsMinThreads**

Specifies the minimum number of jobs the dynamic agent can run concurrently. For example, to allow the dynamic agent to run a minimum of 500 jobs concurrently, set this parameter to **500**. The default is **38**. Modify if the number of expected concurrent jobs is much higher than 38. The agent dynamically allocates more threads if necessary, until it reaches the value specified in **ExecutorsMaxThreads**.

**FilePermissions**

The access rights assigned to the agent for creating files when running jobs. The default is **0755**. Supported values are UNIX-format entries in hexadecimal notation.

**MaxAge**

The number of days that job logs are kept (in path *TWA\_home/TWS/stdlist/JM*) before being deleted. The default is **30**. Possible values range from a minimum of 1 day.

**NotifierMaxThreads**

Notifier threads are in charge of notifying the dynamic workload broker of each status change in a job. This parameter specifies the maximum number of job status changes that can be notified to the dynamic workload broker.

**NotifierMinThreads**

Notifier threads are in charge of notifying the dynamic workload broker of each status change in a job. This parameter specifies the minimum number of job status changes that can be notified to the dynamic workload broker. The default value is **3**. Modify this parameters only in case of unexpected errors and after consulting with software support team.

**SpoolDir**

The path to the folder containing the jobstore and outputs. The default is:

**On Windows operating systems**

```
TWA_home/TWS/stdlist/JM
```

**On UNIX operating systems**

```
$(TWA_DATA_DIR/stdlist/JM)
```

**StackSizeBytes**

The size of the operating system stack in bytes. The default is **DEFAULT**, meaning that the **agent** uses the default value for the operating system. Do not modify this parameter unless instructed to do so by the software support team. Incorrect values can cause the agent to crash.

## Configuring properties of the native job launcher [NativeJobLauncher]

**About this task**

In the `JobManager.ini` file, the section containing the properties of the native job launcher is named:

```
[NativeJobLauncher]
```

You can change the following properties:

**AllowRoot**

Applies to UNIX™ systems only. Specifies if the root user can run jobs on the agent. It can be `true` or `false`. The default is `false`. This property does not apply to IBM i, use the `AllowQSECOFR` option instead

**AllowQSECOFR**

Applies to IBM i systems only. Specifies if QSECOFR user can run jobs on the agent. It can be `true` or `false`. The default is `true`. Add a line like `AllowQSECOFR = false` to the `JobManager.ini` file to deny job execution to QSECOFR.

**CheckExec**

If `true`, before launching the job, the agent checks both the availability and the execution rights of the binary file. The default is `true`.

**DefaultWorkingDir**

Specifies the working directory of native jobs. You can also specify the value for the working directory when creating or editing the job definition in the Graphical Designer. When specified in the Graphical Designer, this

value overrides the value specified for the **DefaultWorkingDir** property. If you do not specify any working directories, the `<TWS_home>\bin` directory is used.

### JobUnspecifiedInteractive

Applies to Windows™ operating systems only. Specifies if native jobs are to be launched in interactive mode. It can be `true` or `false`. The default is `false`.

### KeepCommandTraces

Set to `true` to store the traces of the method invocation for actions performed on a job definition, for example, when selecting from a picklist. These files are stored in the path `/opt/IBM/TWA_<TWS_user>/TWS/stdlist/JM/r3batch_cmd_exec`. The default setting is `false`.

### KeepJobCommandTraces

Set to `true` to store the traces of the method invocation for actions performed on a job instance, for example, viewing a spool list. These files are stored in the `.zip` file of the job instance. The default setting is `true`.

### LoadProfile

Applies to agents on Windows servers only. Specifies if the user profile is to be loaded. It can be `true` or `false`. The default is `true`.

### MonitorQueueName

Specifies the name of the queue where the IBM i jobs are monitored. If you do not specify this property, the default queue (QBATCH) is used.

### PortMax

The maximum range of the port numbers used by the task launcher to communicate with the Job Manager. The default is 0, meaning that the operating system assigns the port automatically.

### PortMin

The minimum range of the port numbers used by the task launcher to communicate with the Job Manager. The default is 0, meaning that the operating system assigns the port automatically.

### PostJobExecScriptPathName

The fully qualified path of the script file that you want to run when the job completes. By default, this property is not present in the `JobManager.ini` file. If you do not specify any file path or the script file doesn't exist, no action is taken.

This property applies to dynamic agent and z/OS agent. For details about running a script when a job completes, see *User's Guide and Reference*.

### PromotedNice

Used in workload service assurance. This property is not supported on the Agent for z/OS.

For UNIX and Linux operating systems only, assigns the priority value to a critical job that needs to be promoted so that the operating system processes it before others. Applies to critical jobs or predecessors that need to be promoted so that they can start at their critical start time.

Boundary values vary depending upon each specific platform, but generally lower values correspond to higher priority levels and vice versa. The default is -1.

Be aware that:

- The promotion process is effective with negative values only. If you set a positive value, the system runs it with the -1 default value.
- An out of range value (for example -200), prompts the operating system to automatically promote the jobs with the lowest allowed nice value.
- Overusing the promotion mechanism (that is, defining an exceedingly high number of jobs as mission critical and setting the highest priority value here) might overload the operating system, negatively impacting the overall performance of the workstation.

### PromotedPriority

Used in workload service assurance. This property is not supported on the Agent for z/OS.

For Windows operating systems only, sets to this value the priority by which the operating system processes a critical job when it is promoted. Applies to critical jobs or predecessors that need to be promoted so that they can start at their critical start time. Valid values are:

- High
- AboveNormal (the default)
- Normal
- BelowNormal
- Low Or Idle

Note that if you set a lower priority value than the one non-critical jobs might be assigned, no warning is given.

### RequireUserName

When `true`, requires that you add the user name in the JSDL job definition.

When `false`, runs with the user name used by job manager, that is:

- `TWS_user` on UNIX™ and Linux™ systems
- The local system account on Windows™ systems

The default is `false`.

### RunExecutablesAsIBMiJobs

If you set this property to `true`, you can define IBM i jobs as generic jobs without using the XML definition. Generic jobs are automatically converted to IBM i jobs. As a side effect, generic jobs cannot be run when this parameter is enabled (`RunExecutablesAsIBMiJobs=true`). There is no default value because this property is not listed in the `JobManager.ini` file after the agent installation.



If you set this property to `true`, ensure that the user you used to install the agent has been granted the `*ALLOBJ` special authority.

### RunInteractiveJobOnInvalidSession

Applies only to native and executable jobs starting interactive programs running on dynamic agents installed on Windows operating systems. Interactive programs run only if the job user has an active session open when the job runs. If there is no active session for the job user, the job behavior is defined by this property, as follows. Set the property to `true` to enable jobs to start interactive programs even if there is no active session for the job user. Set the property to `false` to prevent jobs from starting interactive programs if there is no active session for the job user.

### ScriptSuffix

The suffix to be used when creating the script files. It is:

`.cmd`

For Windows™

`.sh`

For UNIX™

### VerboseTracing

Enables verbose tracing. It is set to `true` by default.

## Configuring properties of the Java™ job launcher [JavaJobLauncher]

### About this task

In the `JobManager.ini` file, the section containing the properties of the Java™ job launcher is named:

```
[JavaJobLauncher]
```

You can change the following property:

### JVMOptions

The options to provide to the Java™ Virtual Machine used to start job types with advanced options. Supported keywords for establishing a secure connection are:

- `https.proxyHost`
- `https.proxyPort`

Supported keywords for establishing a non-secure connection are:

- `Dhttp.proxyHost`
- `Dhttp.proxyPort`

For example, to set job types with advanced options, based on the default JVM http protocol handler, to the unauthenticated proxy server called with name `myproxyserver.mycompany.com`, define the following option:

```
JVMOptions = -Dhttp.proxyHost=myproxyserver.mycompany.com -Dhttp.proxyPort=80
```

## Configuring properties of the Resource advisor agent [ResourceAdvisorAgent]

### About this task

In the `JobManager.ini` and `JobManagerGW.ini` files, the section containing the properties of the Resource advisor agent is named:

```
[ResourceAdvisorAgent]
```

You can change the following properties:

#### BackupResourceAdvisorUrls

The list of URLs returned by the IBM Workload Scheduler master in a distributed environment or by the dynamic domain manager either in a z/OS or in a distributed environment. The agent uses this list to connect to the master or dynamic domain manager.

#### CPUScannerPeriodSeconds

The time interval that the Resource advisor agent collects resource information about the local CPU. The default value is every 10 seconds.

#### FullyQualifiedHostname

The fully qualified host name of the agent. It is configured automatically at installation time and is used to connect with the master in a distributed environment or with the dynamic domain manager in a z/OS or in a distributed environment. Edit only if the host name is changed after installation.

#### NotifyToResourceAdvisorPeriodSeconds

The time interval that the Resource advisor agent forwards the collected resource information to the Resource advisor. The default value is every 119 seconds.

#### ResourceAdvisorUrl

##### JobManager.ini

The URL of the master in a distributed environment, or of the dynamic domain manager in a z/OS or in a distributed environment, that is hosting the agent. This URL is used until the server replies with the list of its URLs. The value is `https://$(tdwb_server):$(tdwb_port)/JobManagerRESTWeb/JobScheduler/resource`, where:

##### **\$(tdwb\_server)**

is the fully qualified host name of the master in a distributed environment or of the dynamic domain manager either in a z/OS or in a distributed environment.

##### **\$(tdwb\_port)**

is the port number of the master in a distributed environment or of the dynamic domain manager either in a z/OS or in a distributed environment.

It is configured automatically at installation time. Edit only if the host name or the port number are changed after installation, or if you do not use secure connection (set to `http`). If you set the port number to zero, the resource advisor agent does not start. The port is set to zero if at installation time you specify that you will not be using the master in a distributed environment or the dynamic domain manager either in a z/OS or in a distributed environment.

In a distributed environment, if **-gateway** is set to either `local` or `remote`, then this is the URL of the dynamic agent workstation where the gateway resides and through which the dynamic agents communicate. The value is `https://$(tdwb_server):$(tdwb_port)/ita/JobManagerGW/JobManagerRESTWeb/JobScheduler/resource`, where:

**`$(tdwb_server)`**

The fully qualified host name of the dynamic agent workstation where the gateway resides and through which the dynamic agent communicates with the dynamic workload broker.

**`$(tdwb_port)`**

The port number of the dynamic agent workstation where the gateway resides and through which the dynamic agent communicates with the dynamic workload broker.

**JobManagerGW.ini**

In a distributed environment, if **-gateway** is set to `local`, then **ResourceAdvisorUrl** is the URL of the master or dynamic domain manager. The value is `https://$(tdwb_server):$(tdwb_port)/JobManagerRESTWeb/JobScheduler/resource`, where:

**`$(tdwb_server)`**

The fully qualified host name of the master or dynamic domain manager.

**`$(tdwb_port)`**

The port number of the master or dynamic domain manager.

**ScannerPeriodSeconds**

The time interval that the Resource advisor agent collects information about all the resources in the local system other than CPU resources. The default value is every 120 seconds.

The resource advisor agent, intermittently scans the resources of the machine (computer system, operating system, file systems and networks) and periodically sends an update of their status to the master or dynamic domain manager either in a z/OS or in a distributed environment.

The CPU is scanned every `CPUScannerPeriodSeconds` seconds, while all the other resources are scanned every `ScannerPeriodSeconds` seconds. As soon as one of the scans shows a significant change in the status of a resource, the resources are synchronized with the master in a distributed environment or the dynamic domain manager either in a z/OS or in a distributed environment. The following is the policy followed by the agent to tell if a resource attribute has significantly changed:

- A resource is added or deleted
- A string attribute changes its value
- A CPU value changes by more than `DeltaForCPU`
- A file system value changes by more than `DeltaForDiskMB` megabytes
- A Memory value changes by more than `DeltaForMemoryMB` megabytes

If there are no significant changes, the resources are synchronized with the IBM Workload Scheduler master in a distributed environment or with the dynamic domain manager either in a z/OS or in a distributed environment every `NotifyToResourceAdvisorPeriodSeconds` seconds.

## Configuring properties of the System scanner [SystemScanner]

### About this task

In the `JobManager.ini` file, the section containing the properties of the System scanner is named:

```
[SystemScanner]
```

You can change the following properties:

#### **CPUSamples**

The number of samples used to calculate the average CPU usage. The default value is 3.

#### **DeltaForCPU**

The change in CPU usage considered to be significant when it becomes higher than this percentage (for example, `DeltaForCPU` is 20 if the CPU usage changes from 10 percent to 30 percent). The default value is 20 percent.

#### **DeltaForDiskMB**

The change in use of all file system resources that is considered significant when it becomes higher than this value. The default value is 100 MB.

#### **DeltaForMemoryMB**

The change in use of all system memory that is considered significant when it becomes higher than this value. The default value is 100 MB.

## Configuring properties of event-driven workload automation [EventDrivenWorkload]

### About this task

In the `JobManager.ini` file, the section containing the properties of event-driven workload automation is named:

```
[EventDrivenWorkload]
```

 **Important:** Do not modify the values of these properties, however, you can consult them for troubleshooting purposes.

The following properties are contained in this section:

#### **EventProcessorHostname**

The host name where the event processor is located.

#### **ThisWorkstation**

The name of the agent workstation where the JobManager.ini file, containing these properties, is located.

#### **EventProcessorEifSslPort**

The Event Integration Facility (EIF) port number where the event processing server receives events when it is SSL-protected.

#### **EventProcessorEifPort**

The EIF port number where the event processing server receives events.

#### **EdwaDesiredStatusRunning**

To enable event-driven workload automation set to `true`, otherwise, `false`. The default value is `true`.

#### **CRC**

The current cyclic redundancy check (CRC) of the event rules of this workstation as reported by the event processor.

#### **DeployedCRC**

The CRC of the event rules already deployed.

#### **EventProcessorWorkstation**

The name of the workstation on which the event processor is located.

#### **EventProcessorPort**

The port number used to contact the event processor.

#### **EventProcessorContext**

The context part of the unified resource identifier (URI) of the event processor.

#### **EventProcessorProtocol**

The protocol used to contact the event processor. Valid values: `http`, `https`. The default value is `https`.

## Regular maintenance

Regular maintenance refers to the mechanisms that are used on your dynamic workstation agents to free up storage space and improve performance.

Unlike IBM Workload Scheduler fault-tolerant agents, where maintenance tasks must be performed manually using the `rmstdlist` utility command, you can have regular maintenance performed on your dynamic agent workstations to keep disk space under control by configuring the following parameters as appropriate.

**Table 2. Agent configuration parameters**

File	Parameter	Description
JobManager.ini located in the path	MaxAge	The number of days that job logs are kept before being deleted. The default is 2. Possible values range from a minimum of 1 day.
<b>On UNIX™ operating systems</b>		
<code>TWA_DATA_DIR/ITTA/cpa/config/JobManager.ini</code>	JobManager.loggerhd.maxFileBytes	The maximum size that the log file can reach. The default is 1024000 bytes.
<b>On Windows™ operating systems</b>		
<code>TWA_home\TWS\ITA\cpa\config\JobManager.ini</code>	JobManager.loggerhd.maxFiles	The maximum number of log files that can be stored in the <code>stdlist/JM</code> directory. The default is 3.
	JobManager.ffdc.maxDiskSpace	The maximum disk space reached, by the log files collected by the First Failure Data Capture tool, after which the oldest files are removed.
	JobManager.trhd.maxFileBytes	The maximum size that the log file can reach. The default is 10240000 bytes.
	JobManager.trhd.maxFiles	The maximum number of log files that can be stored. The default is 5.
logging.properties located in the path	java.util.logging.FileHandler.limit	The maximum amount to write log messages to a file. Default value is 1000000 (bytes)
<b>On UNIX™ operating systems</b>		
<code>TWA_DATA_DIR/TWS/JavaExt/cfg/</code>	java.util.logging.FileHandler.count	The number of output files to cycle through. Default value is 10.
<b>On Windows™ operating systems</b>		
<code>TWA_home\TWS\JavaExt\cfg/</code>		

Logs related to jobs with advanced options.

## Configuring the Z controller

This section describes the configuration steps required on the Z controller.

## Defining destinations with the ROUTOPTS statement

IBM Z Workload Scheduler Agents and dynamic domain managers are connected to the Z controller. This means that you use the ROUTOPTS statement to define the connection details of an IBM Z Workload Scheduler Agent and dynamic domain manager to the controller or standby controller.

Set the HTTP or HTTPS keyword to define all your IBM Z Workload Scheduler Agent destinations. For IBM Z Workload Scheduler Agents and dynamic domain managers, a destination is the combination of a name and the fully qualified host name, or IP address, and port number of the IBM Z Workload Scheduler Agent or dynamic domain manager.

HTTP and HTTPS have the same syntax. The difference is that HTTPS defines the connection as SSL-secure. ROUTOPTS is defined in the member of the EQQPARM library specified by the PARM parameter in the JCL EXEC statement of the controller.

The syntax for defining IBM Z Workload Scheduler Agent and dynamic domain managers destinations is the following:

```
ROUTOPTS HTTP|HTTPS(destination, . . . ,destination)
```

where *destination* is indicated as follows:

### For IBM Z Workload Scheduler Agents

```
dest name: 'hostname or IPaddr of agent' /port of agent[/type] [/pulseivl] [/proxyname]
```

For more information, see [Figure 1: Static end-to-end environment with Java run time installed in which you can run job types with advanced options on page 13](#).

### For dynamic domain managers

```
hostname or IPaddress of DDM/port of DDM/B[/pulseivl]
```

For more information, see [Figure 2: Dynamic end-to-end environment to run also job types with advanced options. on page 14](#).

### For master domain managers

```
hostname or IPaddress of MDM/port of MDM/B
```

The destination name is any alphanumeric sequence of up to 8 characters. You can include as many destinations as you want within the parentheses. They must be separated by commas. Because you cannot specify more than 455 lines for each ROUTOPTS statement, you can add further destinations by specifying more than one ROUTOPTS statement.

The *pulseivl* value is optional and defines the frequency, expressed in minutes, with which the IBM® Z Workload Scheduler controller checks that the agent or dynamic domain manager is running. Values range from 0 to 1440 minutes; the value 0 means that the heartbeat checking:

- Is not run for z-centric agents.
- Is run for dynamic domain managers according to the policy established by the Z controller.

For details, see [Configuring the heartbeat checking interval for z-centric agents and dynamic domain managers on page 42](#).



**Note:** Any `pulseivl` value defined in a `ROUTOPTS HTTP|HTTPS destination` statement overrides the global value eventually defined with the `HTTPOPTS PULSEIVL` keyword.

The following example specifies the destinations to two IBM Z Workload Scheduler Agents:

```
ROUTOPTS HTTPS(ITAAC1:'192.27.144.12'/44112, ITAAC2:'192.14.55.231'/61424//10)
```

where a heartbeat checking interval of 10 minutes is set for ITAAC2. Note that if you use `pulseivl`, there must be two slashes (/) before it because the `type` parameter for z-centric agents is null.

The following example specifies the destination to one dynamic domain manager:

```
ROUTOPTS HTTPS(BRKS:'9.168.125.59'/8081/B/5)
```

where a heartbeat checking interval of 5 minutes is set for the dynamic domain manager. For more information about the `ROUTOPTS` statement, see *Customization and Tuning*.

The `proxyname` value is optional: you specify it when one or more z-centric agents are connected to the controller through a proxy server. You must have defined the `proxyname` in the `PROXY` parameter of `ROUTOPTS`.

The following example defines that the z-centric agents `ZCENT1` and `ZCENT2` are connected to the controller through the proxy server named `PRX1` (you defined `PRX1` in the `PROXY` parameter of `ROUTOPTS`):

```
ROUTOPTS HTTPS(ZCENT1:'192.27.144.12'/8081///PRX1, ZCENT2:'192.14.55.231'/16789//5/PRX1)
PROXY(PRX1:'195.34.134.10'/3741)
```

You can modify, add, or delete an HTTP or HTTPS destination while IBM Z Workload Scheduler is running. To make the changes immediately effective, without stopping and restarting the controller, issue the `MODIFY` command `/F procname, RFRDEST`.



**Note:** The `RFRDEST` command does not update any changes you make to the `PROXY` parameter in `ROUTOPTS`, it updates only the HTTP | HTTPS destinations, including the `proxy name`. For detailed information about `RFRDEST`, see *Managing the Workload*.

To list the HTTP and HTTPS destinations that are currently used by the controller, enter the following `MODIFY` command (the list is stored in the `MLOG`):

```
/F procname, DSPDEST
```

For detailed information about the `DSPDEST` command, see *Managing the Workload*.

You can add a maximum of 100 destinations, without having to restart the controller. The `MODIFY` command manages up to a total of 100 new destinations, regardless if you add them at once or at different times. After 100 destinations added, you must stop and restart the controller to have the `MODIFY` command manage other 100 new destinations.



**Note:** Deleting a destination does not increment the number of maximum additions allowed.

You can modify or delete an unlimited number of destinations. However, if you modify the destination `name` this operation is considered as adding a new destination.



## Chapter 2. Customizing the HTTP connections

The communication between the IBM Z Workload Scheduler Agents and the IBM Z Workload Scheduler controller is direct, through the HTTP or HTTPS protocol.

This chapter includes the following customization topics for the HTTP/HTTPS connections:

- [Customizing the HTTP connection with the HTTPOPTS statement on page 41](#)
- [Customizing the HTTP timeout on the Dynamic Workload Console on page 41](#)

### Customizing the HTTP connection with the HTTPOPTS statement

HTTPOPTS statement to customize HTTP connection.

You can optionally use the HTTPOPTS initialization statement to define a number of parameters for IBM Z Workload Scheduler Agents and dynamic domain managers, for example:

- Variable tables to be used when running job types with advanced options.
- Job log retrieval parameters.

You do not have to define the TCPIPJOBNAME and the HOSTNAME parameters if you already have a TCPOPTS initialization statement that includes them. Define the job log retrieval parameters if you want to change the defaults.

For a detailed description of the HTTPOPTS and TCPOPTS statements, see *Customization and Tuning*.

### Customizing the HTTP timeout on the Dynamic Workload Console

You can increase the length of the HTTP connection timeout in the Dynamic Workload Console to allow more time for retrieving objects related to the z-centric environment.

If you find that you get message errors, such as:

```
AWSJZC019E A communication error has occurred with IBM® Z Workload Scheduler.  
The connection wait has exceeded the timeout of "30,000" milliseconds...
```

when you try to retrieve z-centric objects from the z/OS engine on the Dynamic Workload Console, this implies that the HTTP/HTTPS connections within your z-centric environment might be suffering or that some of your plug-in applications require longer than expected.

To mitigate this problem you can increase the timeout allowed on the Dynamic Workload Console when receiving data from the IBM Z Workload Scheduler controller.

To do so, set the `zosHttpTimeout` option of the `TdwcGlobalSettings.xml` file that configures the global settings of the Dynamic Workload Console.

If the option is not set, it takes the default value of 30,000 milliseconds (ms), which is probably not enough to fulfill your requirements. In this case, add the option in `TdwcGlobalSettings.xml` and set a value larger than 30,000 ms (for example, 90,000 ms).

For additional information, see the *Dynamic Workload Console User's Guide*.

## Configuring the heartbeat checking interval for z-centric agents and dynamic domain managers

You can configure the IBM® Z Workload Scheduler controller to check at intervals if all or specific attached z-centric agents and dynamic domain managers are running. Without the use of this mechanism the controller does not register, until the next job submission occurs, that a workstation has become unavailable. This may impact your scheduling plans.

The use of this feature is optional and configurable by adding the PULSEIVL keyword in the following IBM® Z Workload Scheduler initialization statements:

### HTTPOPTS

The value for PULSEIVL is valid globally for all the attached z-centric agents and dynamic domain managers.

### ROUTOPTS

PULSEIVL is featured as a parameter in the `HTTP/HTTPS destination` keyword and in this case defines the heartbeat checking interval of the specific agent defined in the destination. This option is useful when heartbeat checking is wanted only on the more strategic agents or when a different checking frequency is desired.

The pulse interval of a destination can be updated using the `HTTP refresh destination` command without having to stop the controller.

The value is expressed in minutes and can range from 0 to 1440. The value 0 means that the heartbeat checking:

- Is not run for z-centric agents.
- Is run for dynamic domain managers according to the policy established by the Z controller.

For example:

```
HTTPOPTS  ...
          PULSEIVL(60)
          ...

ROUTOPTS  HTTPS(DDM1:'162.17.129.32'/65232/B/5)
```

This configuration sets a heartbeat checking interval of 60 minutes for all z-centric agents and dynamic domain managers, but for DDM1 the interval is set to 5 minutes.

For details about the HTTPOPTS and ROUTOPTS initialization statements, see *Customization and Tuning*.

## Configuring the connection between the IBM Z Workload Scheduler Agent and Z controller through a proxy

You can configure that one or more z-centric agents connect with the controller through a proxy server, by defining the proxy properties in the ROUTOPTS statement and `JobManager.ini` file.

**About this task**

On the controller, set the proxy properties in ROUTOPTS by performing the following steps:

1. Define one or more proxy destinations as follows:

```
ROUTOPTS PROXY(destination, ..., destination)
```

Each *destination* has the following syntax:

```
proxy name: 'IP address or hostname' / port
```

where:

***proxy name***

The name assigned to the destination, up to 8 alphanumeric characters.

***IP address or hostname***

The fully qualified host name or IP address used to communicate with the proxy server. It can be up to 52 alphanumeric characters.

***port***

The port number used to communicate with the proxy server.

2. In the HTTP|HTTPS parameter specify the *proxy name* that you defined, as follows:

```
ROUTOPTS HTTP|HTTPS(dest name: 'IPaddr or hostname' / port [ / type ] [ / pulseiv ] [ / proxy name ])
```

3. On the z-centric agent, edit the [ITA\_Env] section of the JobManager.ini file as described in [Configuring proxy properties \[ITA\\_Env\] on page 21](#)

The following example shows a ROUTOPTS statement:

```
ROUTOPTS PROXY(PROX1: '192.27.144.13' / 44113, PROX2: '192.27.144.14' / 44118) 1
          HTTP(ZCENT1: '192.27.144.12' / 44112 /// PROX2, ZCENT2: '192.14.55.231' / 61424 /// PROX2) 2
          HTTPS(ZCENT3: '192.27.144.13' / 8913 / Z // PROX1) 3
```

where:

**1**

Two proxy destinations, PROX1 and PROX2, are configured.

**2**

The z-centric agents ZCENT1 and ZCENT2 connect with the controller through proxy PROX2.

**3**

The z-centric agent ZCENT3 connects with the controller through proxy PROX1, in an SSL-secure connection.

## Starting and stopping HTTP subtasks

An HTTP Server subtask and an HTTP Client subtask run the transmission of data between the scheduler and the IBM Z Workload Scheduler Agents on the distributed side. These subtasks automatically start at controller startup.

At anytime you can start or stop a subtask while IBM Z Workload Scheduler is running by using the MODIFY command. You can enter this command from a multiple console support (MCS) console or from a program such as the spool display and search facility (SDSF). In both cases, the terminal or console operator must have the required authority to enter operator commands.

Enter the MODIFY command as follows:

```
/F procname,modifyoption
```

where:

**procname**

Is the IBM Z Workload Scheduler controller JCL procedure name.

**modifyoption**

Can be one of the following:

**S=taskname**

Start the specified subtask.

**P=taskname**

Stop the specified subtask.

where *taskname* is either of the following:

**HTC**

The HTTP Client subtask

**HTS**

The HTTP Server subtask

## Chapter 3. Defining user IDs and passwords with the USRREC statement

Use the USRREC initialization statement to define the passwords for the users who need to schedule jobs to run on Windows™ workstations. You do not need to do this if you run [native on page 98](#) job types on non-Windows workstations.

If you run job types with advanced options ([database on page 76](#), [file transfer on page 84](#), [web service on page 90](#), [xajob on page 94](#), [J2EE jms on page 96](#)) you can use USRREC regardless of the operating system. The advantage of doing this is that you do not have to hard code the password in the job definition as it will be retrieved from the IBM Z Workload Scheduler database at run time.

If the statement is very long and needs to be split into two lines, use the comma (,) as a continuation character to continue the string to the next line.

USRREC is defined in the member of the EQQPARM library specified by the USRMEM keyword in the HTTPOPTS statement.

You can make changes to the USRREC statement while IBM Z Workload Scheduler is running. To make them immediately effective, without stopping and restarting the controller, enter the following MODIFY operator command:

```
/F procname,RFRUSER
```

where *procname* is the IBM Z Workload Scheduler JCL procedure name.

For more information about the MODIFY command, see the section about modifying the scheduler in *Managing the Workload*. For more information about the USRREC statement, see [USRREC on page 45](#).

## USRREC

### Purpose

This statement defines the passwords for the users who need to schedule native jobs to run on Windows™ workstations, or who want to use this feature when defining job types with advanced options that will run on workstations based on any operating system.

After you have defined a user and its password, you use these values as follows in the definitions of job types with advanced options:

#### The value in USRNAM

- In the JOBREC job definition statement, it is specified as the value of the JOBUSR keyword.
- In the definition panel of the job in the Dynamic Workload Console it is specified in the `User Name` field of the `Credentials` section.

#### The value in USRPSW

Is resolved at run time if you:

- Specify `y` for the `JOBPWD` keyword in the `JOBREC` job definition statement.
- Select `User` in the `Password type` widget that is displayed by clicking the ellipsis (...) located by the `Password` field in the `Credentials` section of the job definition panel in the Dynamic Workload Console.

## Format

► `USRREC` — `USRCPU` — ( — `cpu name` — ) — `USRNAM` — ( — `logon ID` — ) — `USRPSW` — ( — `password` — ) ►

## Parameters

### **USRCPU**(*cpu name*)

The IBM Workload Scheduler workstation on which the user can launch jobs. It consists of four alphanumeric characters, starting with a letter.

### **USRNAM**(*logon ID*)

The user name of a Windows™ workstation or the name of the user authorized to run a job type with advanced options. The name is case-sensitive and can be of up to 47 characters.

If you are defining a user that will run native jobs on Windows workstations, note that:

- The name can include a domain name and might be case-sensitive, depending on the Windows™ version.
- The user must be able to log on to the computer on which IBM Workload Scheduler has launched jobs, and must also be authorized to *Log on as batch*.
- If the name is not unique in Windows™, it is considered to be either a local user, a domain user, or a trusted domain user, in that order.
- If you are defining a Windows™ domain user and the value contains a backslash (\), then the entire character string must be enclosed by single quotes, for example:

```
USRNAM('XXXXX\user1')
```

- If you are defining a Windows™ user in the *username@internet\_domain* format that contains the at sign (@), for example `administrator@mywindow.com`, you must enclose the entire character string in single quotes:

```
USRNAM('administrator@mywindow.com')
```

### **USRPSW**(*password*)

The password for the user specified in `USRNAM`. It can consist of up to 31 characters and must be enclosed in single quotation marks. It is case-sensitive.

The password is stored in the `USRINFO` member in plaintext, meaning that it is *not encrypted*. To encrypt it, run the sample provided in the `EQQBENCR` member of the `EQQSAMP` library.

If the password is for a user that will run native jobs on Windows workstations, note that:

- The password might be case-sensitive, depending on the Windows™ version.
- If you are defining a Windows™ domain user and the value contains a backslash (\), then the entire character string must be enclosed by single quotes, for example:

```
USRPSW('XXXXX\password1')
```

- If you are defining a password for the Windows™ user in the *username@internet\_domain* format that contains the at sign (@), for example `administrator@mywindow.com`, you must enclose the entire character string in single quotes:

```
USRPSW('passw0rd')
```

# Chapter 4. Defining variables and passwords for local resolution

You can set variables and passwords to be defined and resolved locally on the IBM® Z Workload Scheduler agents.

This is particularly useful in the case of passwords because you are not required to specify them in the job definition. The advantage is that, if the password has to change, you do not modify the job definition, but you change it with the `param` command locally on the agents (or on the pool agents) that run or may run the job.

This feature is not restricted to Windows workstations alone. You can use it also on UNIX, as long as you apply it on job types with advanced options.

See the following sections for:

- [Creating and managing variables and passwords on the agents on page 48.](#)
- [Specifying variables and passwords in the JOBLIB statement on page 51](#) in the JOBLIB data set.
- [Specifying local variables and passwords in job types with advanced options on page 52](#) to define your job in the Dynamic Workload Console so that the variables or passwords are resolved locally on the agents at run time.

## Creating and managing variables and passwords on the agents

Use the `param` command to define and manage user passwords and variables locally on the IBM® Z Workload Scheduler agents. The values are resolved at submission time on the agent where the job is submitted.

### Authorization

To create, delete, or display variables or passwords, you must have Administrator or root user rights on the workstation that runs the agent or `TWS_user` rights on the agent.

### Syntax

```
param -u | -V |  
  {-c | -ec} [file.section.|file..|section.] variable [value] |  
  [file.section.|file..|section.] variable |  
  {-d | -fd} [file.section.|file..|section.] variable
```

### Arguments

**-u**

Displays command usage information and exits.

**-V**

Displays the command version and exits.



**-c | -ec**

Creates variable or password *variable* and defines its value *value*. The variable or password is placed in a namespace *file* that you can organize in one or more sections named *section*.

If you do not provide a file name *file*, the variable or password is placed in default file `jm_variables` in path `agent_installation_path\TWA\TWS\ITA\cpa\config\jm_variables_files (/TWA/TWS/ITA/cpa/config/jm_variables_files)` on the agent.

If you do not provide a section name *section*, the variable or password is placed in the main body of the file.



**Important:** If you are defining a password, you must specify a section named `password` for *variable*. This specifies that *variable* is a password.

If you are creating a variable, *variable* is the variable name and *value* is its value. If you are creating a password, *variable* is the user name and *value* is its password. If you do not enter *value* within the arguments, the command requests interactively to enter a value.

Argument `-c` creates the variable in clear form. Argument `-ec` creates the variable in encrypted form. Passwords are encrypted by default also if you use `-c`.

**-d | -fd**

Deletes (`-d`) or forces deletion (`-fd`) of a file, section, or variable (password). You can use the following wildcards:

\*

Replaces one or more alphanumeric characters.

?

Replaces one alphanumeric character.

With `-d` the command asks for confirmation before deleting. With `-fd` it deletes without asking confirmation.

When you delete all the variables in a section, the section is removed from the file. When you delete all the sections and all the variables from a file, the file is removed.

**file**

The name of the file used as a namespace for *variable*. If you do not specify *file*, the command uses the default file `jm_variables` in path `agent_installation_path\TWA\TWS\ITA\cpa\config\jm_variables_files (/TWA/TWS/ITA/cpa/config/jm_variables_files)`.

All the variable namespaces go in path `agent_installation_path\TWA\TWS\ITA\cpa\config\jm_variables_files (/TWA/TWS/ITA/cpa/config/jm_variables_files)`.

**section**

The name of the section within *file* where *variable* is defined. When *variable* is used for a password, it must be placed in a section named `password`. No section name is required to store variables.

**value**

The value for *variable*.

**variable**

Can be a variable name or a user identification. If it is used for identification, it must be placed in a section named `password` within the namespace file.

**Comments**

To display a variable or password, a namespace file, or a section, use the command as follows:

```
param [file.section.|file..|section.] variable
```

where you can use the \* and ? wildcards described for the deletion command.

The namespace files, including default `jm_variables`, have no extension.

Variable names are case sensitive.

On IBM i systems, if you use the QP2TERM and the QSH shells, passwords are made visible during the creation process with `param` and are displayed clearly in the shell logs. To guarantee the obfuscation of a password, you need to use the AIXTERM or XTERM shells.

**Example****Examples**

The command:

```
param -c compassets.hardware.platform1 unix
```

defines variable `platform1` with value `unix` in section `hardware` of the new or existing file named `compassets`. The value is not encrypted.

The command:

```
param -c compassets..platform1 unix
```

defines variable `platform1` with value `unix` in the new or existing file named `compassets`. The value is not encrypted.

The command:

```
param -ec hardware.platform1 unix
```

defines variable `platform1` with value `unix` in section `hardware` in the default file `agent_installation_path\TWA\TWS\ITA\cpa\config\jm_variables_files\jm_variables`. The value is encrypted.

The command:

```
param -c compassets.password.jladams san07rew
```

defines variable `jladams` with value `san07rew` in section `password` of the new or existing file named `compassets`. Since `jladams` is defined in section `password`, it is interpreted as a username. The value `san07rew` is encrypted by default since it is interpreted as a password.

The command:

```
param *.*.platform1
```

lists variable `platform1` in all its defined locations. That is:

```
..\TWA\TWS\ITA\cpa\config\jm_variables_files\compassets.hardware.platform1=unix
..\TWA\TWS\ITA\cpa\config\jm_variables_files\compassets..platform1=unix
..\TWA\TWS\ITA\cpa\config\jm_variables_files\jm_variables.hardware.platform1=**
```

The command:

```
param password.*adam*
```

lists all variables including the string `adam` contained in the `password` section of all files. In this case:

```
..\TWA\TWS\ITA\cpa\config\jm_variables_files\compassets.password.jladams=*****
```

The command:

```
param -d compassets.password.jladams
```

deletes variable `jladams`.

The command:

```
param -d compassets.password.*
```

deletes all the variables found in section `password` and therefore removes this section from file `compassets`.

The command:

```
param -d compassets.*.*
```

deletes all the contents (variables and sections containing variables) found in file `compassets` and therefore removes the file.

## Specifying variables and passwords in the JOBREC statement

After defining a variable and its value with the `param` command, to add it within a job definition with the JOBREC statement, use the following format. The values are resolved at submission time on the agent where the job is submitted.

### Format

```
//JOBREC
  JOBUSR(username)
  JOBPWD(AGENT)
//END JOBREC
```

where:

#### **JOBUSR(*username*)**

The name of the user to access WebSphere® Application Server, if required. If the user schedules jobs to run on Windows™ workstations, ensure that a user password is also defined with the JOBPWD keyword.

- If you are defining a Windows™ domain user, use the following format:

```
JOBUSR(domainName\user1)
```

- If you are defining a Windows™ user in the *username@internet\_domain* format, use the following format:

```
JOBUSR('administrator@mywindow.com')
```

### JOBPWD(AGENT)

Means that the password is resolved locally on the agent. The password must have been defined on the agent by issuing the [param on page 48](#) command. This feature is available independently of the operating system of the workstation.

## Specifying local variables and passwords in job types with advanced options

After defining a variable and its value with the `param` command, to add it within a job definition so that it is resolved locally on the agent at run time, use the following syntax:

```
${agent:variable_name}
```

After defining a password with the `param` command, to add it within a job definition so that it is resolved locally on the agent at run time, use the following syntax:

```
${agent:password.user_name}
```

You can nest variables within passwords. If you used a variable to define a user, enter the password as follows within the job definition:

```
${agent:password.${agent:variable_name}}
```

where *variable\_name* was previously defined as having value *user\_name* with the `param` command.

### Example

### Example

An IBM Workload Automation administrator needs to define a file transfer job that downloads a file from a remote server to one of the IBM Z Workload Scheduler Agents making up a pool of agents. The administrator wants to parametrize in the job definition:

- The name with which the remote file will be saved locally
- The remote user name and its password

The administrator proceeds in the following way on one of the agents:

1. Defines a variable named `localfile`. The variable is given a value equal to `./npp.5.1.1.Installer.DW.exe` and is created in a new variables file named `FTPvars` (no section). The command to do this is:

```
E:\IBM\TWA\TWS\CLI\bin>param -c FTPvars..localfile ./npp.5.1.1.Installer.DW.exe
```

2. Defines a variable named `remoteUser`. The variable is given a value equal to `FTPuser` and is created in the `FTPvars` file (no section). The command to do this is:

```
E:\IBM\TWA\TWS\CLI\bin>param -c FTPvars..remoteUser FTPuser
```

3. Defines the password for `FTPuser`. The password value is `tdwb8nxt` and is created in the `password` section of the `FTPvars` file. The command to do this is:

```
E:\IBM\TWA\TWS\CLI\bin>param -c FTPvars.password.FTPuser tdwb8nxt
```

4. With a text editor opens file `E:\IBM\TWA\TWS\ITA\cpa\config\jm_variables_files\FTPvars` and checks its contents:

```
localfile = ./npp.5.1.1.Installer.DW.exe
remoteuser = FTPuser

[password]
FTPuser = {aes}XMMYMY2zBHvDEDBo5DdZVmw0Jao60pX1K6x2HhRcovA=
```

5. Copies file `FTPvars` in the `agent_installation_path\TWA\TWS\ITA\cpa\config\jm_variables_files` path of every other agent defined in the pool.
6. Starts defining the new file transfer job in the Workload - Design windows of Dynamic Workload Console. In the `FileTransfer` window:
  - a. Enters `${agent:FTPvars..localfile}` in the `Local file` field.
  - b. Enters `${agent:FTPvars..remoteuser}` in the `Remote Credentials →;User Name` field.
  - c. Clicks the `...` button next to the `Remote Credentials →;Password` field. The `Password type` window pops up and the administrator selects `Agent User`.
  - d. After the administrator clicks the `OK` button for confirmation in the popup window, the `Remote Credentials →;Password` field is complete with the `${agent:password.${agent:FTPvars..remoteuser}}` value.
7. Type in all the other fields to complete the job definition.

When the job is run, the entities and the password entered as variables are resolved with the values defined in the `FTPvars` file.

# Chapter 5. Defining and managing IBM Z Workload Scheduler Agent workstations in the database

After defining the destinations of your IBM Z Workload Scheduler Agents, you need to define the IBM Z Workload Scheduler Agents as IBM Z Workload Scheduler computer automatic workstations.

You can define the IBM Z Workload Scheduler Agents as IBM Z Workload Scheduler computer automatic workstations by using either of the following:

## ISPF

The workstation definition and management panels in ISPF include the `Z-CENTRIC AGENT` field. You can take the following actions on IBM Z Workload Scheduler Agent workstation definitions:

- [Creating on page 54](#)
- [Modifying on page 55](#)
- [Browsing on page 55](#)
- [Deleting on page 56](#)
- [Listing on page 56](#)

## Dynamic Workload Console

For details, refer to the Dynamic Workload Console online help.

## Creating

[Figure 4: EQQWCGEP - Creating general information about an IBM Z Workload Scheduler Agent workstation on page 54](#)

shows the CREATING GENERAL INFORMATION ABOUT A WORK STATION panel, used to create general information about an IBM Z Workload Scheduler Agent workstation named `ZCEN`.

Figure 4. EQQWCGEP - Creating general information about an IBM Z Workload Scheduler Agent workstation

```
EQQWCGEP ----- CREATING GENERAL INFORMATION ABOUT A WORK STATION -----
Command ==>

Enter the command R for resources or A for availability or O for end-to-end
options, or enter/change data below:

WORK STATION NAME   ==> ZCEN
DESCRIPTION         ==> z-centric workstation_----
WORK STATION TYPE   ==> C          G General, C Computer, P Printer
                   ==>          R Remote Engine
REPORTING ATTR      ==> A          A Automatic, S Manual start and completion
                   ==>          C Completion only, N Non reporting
PRINTOUT ROUTING    ==> SYSPRINT  The ddname of daily plan printout data set
SERVER USAGE        ==> B          Parallel server usage, B, N, P, or C
DESTINATION         ==> ITAAC1    Name of destination
Options: allowed Y or N
SPLITTABLE          ==> N          JOB SETUP           ==> N
STARTED TASK, STC   ==> N          WTO                ==> N
AUTOMATION          ==> N
WAIT                ==> N          Z-CENTRIC AGENT     ==> Y
VIRTUAL            ==> N          DYNAMIC            ==> N

REMOTE ENGINE TYPE  ==>          Z z/OS or D Distributed
Defaults:
TRANSPORT TIME      ==> 00.00      Time from previous work station HH.MM
DURATION            ==> 00.05.00  Duration for a normal operation HH.MM.SS
```

Define an IBM Z Workload Scheduler Agent as a computer automatic workstation and enter the destination name previously defined in the ROUTOPTS initialization statement. The Z-CENTRIC AGENT option excludes all other options.

## Modifying

Figure 5: EQQWMGEP - Modifying an IBM Z Workload Scheduler Agent workstation description on page 55 shows the MODIFYING GENERAL INFORMATION ABOUT A WORK STATION panel, used to modify the database definition of an IBM Z Workload Scheduler Agent workstation named ZCEN.

Figure 5. EQQWMGEP - Modifying an IBM Z Workload Scheduler Agent workstation description

```

EQQWMGEP ----- MODIFYING GENERAL INFORMATION ABOUT A WORK STATION -----
Command ==>
Enter the command R for resources A for availability O for end-to-end options
or D for Destinations above, or enter data below:

Work station name      : ZCEN
DESCRIPTION            ==> z-centric workstation-----
WORK STATION TYPE     ==> C          G General, C Computer, P Printer
REPORTING ATTR        ==> A          A Automatic, S Manual start and completion
                                C Completion only, N Non reporting
PRINTOUT ROUTING      ==> SYSPRINT  The ddname of daily plan printout data set
SERVER USAGE          ==> N          Parallel server usage C , P , B or N
DESTINATION           ==> ITAAC1__  Name of destination
Options: allowed Y or N
SPLITTABLE            ==> N          JOB SETUP              ==> N
STARTED TASK, STC    ==> N          WTO                      ==> N
AUTOMATION             ==> N          Z-CENTRIC AGENT        ==> Y
WAIT                   ==> N          DYNAMIC                ==> N
VIRTUAL                ==> N
Defaults:
TRANSPORT TIME        ==> 00.00     Time from previous work station HH.MM
DURATION               ==> -----  Duration for a normal operation HH.MM.SS

```

## Browsing

Figure 6: EQQWBGEP - Browsing an IBM Z Workload Scheduler Agent workstation description on page 55 shows the BROWSING A WORK STATION DESCRIPTION panel, used to browse the database description of an IBM Z Workload Scheduler Agent workstation named ZCEN.

Figure 6. EQQWBGEP - Browsing an IBM Z Workload Scheduler Agent workstation description

```

EQQWBGEP ----- BROWSING A WORK STATION DESCRIPTION -----
Command ==>

Enter the command R for resources, A for availability, O for end-to-end options
or D for Destinations above

Work station          : ZCEN
Description            : z-centric workstation

Work station type     : Computer
Reporting attribute   : Automatic
Printout routing      : SYSPRINT
Server usage          : Neither
Destination           : ITAAC1

Splittable            : No      Job setup              : No
Started task STC     : No      WTO                      : No
AUTOMATION            : No      z-centric agent        : Yes
WAIT                  : No      Dynamic                : No
VIRTUAL               : No
Transport time        : 00.00
Duration              :

```

## Deleting

Figure 7: EQQWDGEP - Deleting an IBM Z Workload Scheduler Agent workstation description. on page 56 shows the CONFIRMING DELETION OF A WORK STATION DESCRIPTION panel, used to delete the database description of an IBM Z Workload Scheduler Agent workstation named *ZCEN*.

Figure 7. EQQWDGEP - Deleting an IBM Z Workload Scheduler Agent workstation description.

```

EQQWDGEP ----- CONFIRMING DELETION OF A WORK STATION DESCRIPTION -----
Command ==>

Enter Y in the command field to confirm deletion or
enter N to reject deletion.

Work station      : ZCEN
Description       : Accts Receivable

Work station type : Computer
Reporting attribute : Automatic

Printout routing  : SYSPRINT
Server usage      : Neither
Destination       : ITAAC1
Splittable        : No      Job setup      : No
Started task STC : No      WTO              : No
AUTOMATION        : No
WAIT              : No      z-centric agent : Yes
VIRTUAL           : No      Dynamic         : No
Transport time    : 00.00
Duration          :
  
```

## Listing

Figure 8: EQQWWSEP - Specifying list selection criteria for IBM Z Workload Scheduler Agent workstations on page 56 shows the SPECIFYING WORK STATION LIST CRITERIA panel, used for specifying selection criteria to list IBM Z Workload Scheduler Agent workstation definitions.

Figure 8. EQQWWSEP - Specifying list selection criteria for IBM Z Workload Scheduler Agent workstations

```

EQQWWSEP ----- SPECIFYING WORK STATION LIST CRITERIA -----
Command ==>

Specify selection criteria below and press ENTER to create a list.

WORK STATION NAME  ==> ----
DESTINATION        ==> -----
TYPE               ==> ----      G, C, P in any combination, or blank
REPORTING ATTRIBUTE ==> -----      A, S, C, N in any combination or blank
AUTOMATION         ==> -          Y, N or blank
WAIT Work station  ==> -          Y, N or blank
VIRT Work station  ==> -          Y, N or blank
z-Centric Agent    ==> Y          Y, N or blank
Dynamic            ==> -          Y, N or blank
  
```

## Managing the status of the IBM Z Workload Scheduler Agent workstation in the plan

Use the WSSTAT command when you want to:

- Change the status of an IBM Z Workload Scheduler Agent workstation in the current plan.
- Verify if the communication between the IBM Z Workload Scheduler Agent workstation and the controller is active.



You use WSSTAT on IBM Z Workload Scheduler Agents in the same way as you do with any other computer automatic workstation.

The status information is communicated to the controller to indicate that a workstation is in one of the following states:

#### **ACTIVE**

The workstation is running and scheduling its own plan.

#### **OFFLINE**

Communication is lost between the controller and the IBM Z Workload Scheduler Agent workstation on the system that the workstation represents. The HTTP client retries to establish the connection until it is successful.

#### **FAILED**

You manually set the workstation status to FAILED.

When you run the WSSTAT command, you can optionally define restart and routing options for the workload defined on the workstation when you are reporting a status of OFFLINE or FAILED.

You can invoke WSSTAT as a TSO command or by using a batch job which runs program EQQEVPGM. If you invoke WSSTAT as a TSO command, you must allocate the EQQMLIB data set to the address space of the TSO user, either by adding DD statements to the logon procedure, or by using the ALLOC command after TSO logon. In the TSO environment, error messages and trace records are sent directly to the terminal user. Messages are not delivered to indicate successful command execution.

Use of the WSSTAT command can be restricted with fixed resource code RL and subresource RL.WSSTAT. The authority of the requester is verified by the subsystem name identified in the command if an AUTHDEF statement is defined for that subsystem. When SUBSYS(MSTR) is specified, all tracker subsystems defined on the z/OS® system where the WSSTAT command is issued attempt to verify the authority of the requester before an event is generated. A requester might be rejected by one subsystem and accepted by another.

The subsystem to which you direct the command need not be active when the command is issued. An event is generated and queued in CSA together with other job-tracking events. If the subsystem is not active when the command is issued, the authority of the requester is verified using the class name specified in the AUTHDEF statement when the subsystem was last started. If the subsystem has not been started since a z/OS® IPL, no authority verification can be performed.



**Note:** If you used the panels to set the status of a workstation to OFFLINE, you cannot reset it to ACTIVE with WSSTAT.

## Automatic and manual changes to the status of the IBM Z Workload Scheduler Agent workstation

At startup, the controller does not establish a connection with an IBM Z Workload Scheduler Agent workstation until the first job is submitted on that IBM Z Workload Scheduler Agent. The workstation status is automatically set to ACTIVE with extended status Waiting for first submission.

When the first job is submitted, the communication between the controller and agent is opened and the workstation is set to ACTIVE.

You can manually change the IBM Z Workload Scheduler Agent workstation status in the following ways:

- From ACTIVE to OFFLINE.
- From ACTIVE, Waiting for first submission to ACTIVE. This operation is also useful to check if the communication between the controller and the agent is established.
- From OFFLINE to ACTIVE.

You cannot set the agent workstation to ACTIVE, if it was set to OFFLINE automatically. In this case, message EQQWL17W is issued:

WORK STATION *WSNAME* CANNOT BE VARIED TO ACTIVE STATUS.  
 A QUERY AGENT INFO REQUEST HAS BEEN SENT TO THE AGENT AT DESTINATION *DEST*.

and the controller tries to establish a connection with the IBM Z Workload Scheduler Agent. If the attempt is successful, the workstation status is set to ACTIVE by the controller.

## WSSTAT

### Format

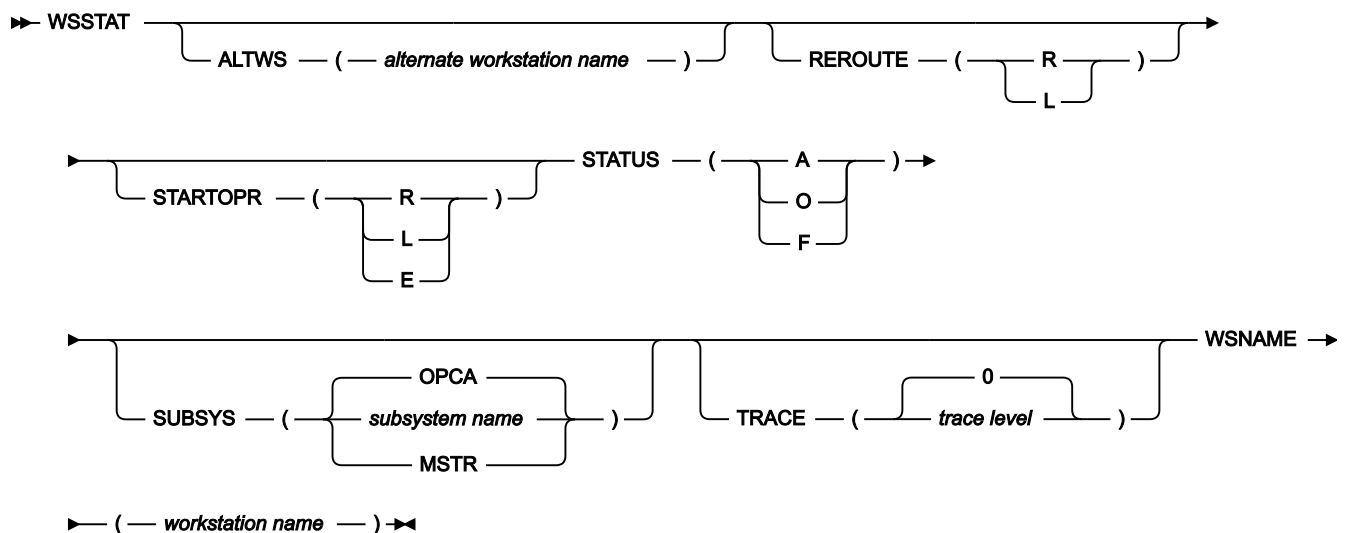

**Note:** These are the only WSSTAT parameters that apply to the IBM Z Workload Scheduler Agent workstation. For a complete list of the WSSTAT parameters, see *Managing the Workload*.

### Parameters

#### ALTWS (*alternate workstation name*)

When the workstation status is set to OFFLINE or FAILED, you can specify the alternate workstation on which to start reroutable operations.

If you omit this parameter, the value defined for the current workstation open interval is used. If the REROUTE parameter specifies L, or if the default specifies no rerouting, the value of ALTWS is ignored.

The parameter is optional.

### REROUTE (R | L)

When the workstation status is set to OFFLINE or FAILED, you can specify R for operations to be rerouted to the alternate workstation, or L for no rerouting (to leave the operations on the inactive workstation).

If you omit this parameter, the value defined in either the WSOFFLINE or the WSFAILURE keyword on the JTOPTS initialization statement is used as the default.

The parameter is optional.

### STARTOPR (R | E | L)

When the workstation status is set to OFFLINE or FAILED, you can specify what the scheduler must do with operations that are currently in started status at the workstation, where:

**R**

Restart operations automatically on the alternate workstation.

**E**

Set all started operations to ended-in-error.

**L**

Leave the operations in started status.

If you omit this parameter, the value defined in either the WSOFFLINE or the WSFAILURE keyword on the JTOPTS initialization statement is used as the default.

The parameter is optional.



**Note:** If you select STARTOPR(E), a started job continues to run, because IBM Z Workload Scheduler never cancels jobs that have started.

### STATUS (A | O | F)

The status you want to report for the workstation:

**A**

Active

**O**

Offline

**F**

Failed

You must specify either STATUS or one of the alternative parameters.

### **SUBSYS** (*subsystem name* | **MSTR** | **OPCA**)

The name of the tracker subsystem that `WSSTAT` is directed to. This parameter can be up to 4 characters long. The first character must be alphabetic while the remaining characters must be alphanumeric. All lowercase characters are converted to uppercase.

If you specify **MSTR**, the command is directed to all tracker subsystems on the z/OS® system on which the command is issued.



**Note:** If the tracker and controller in your configuration run on different subsystems, specify the name of the tracker subsystem in this parameter.

### **TRACE** (*level* | **0**)

The event tracing indicator. When any nonzero positive number is specified, a trace entry is created for each event generated by `WSSTAT`. The trace record is written to the message log file identified by ddname EQQMLOG. The record identifies the name of each receiving subsystem. The default value 0 does not generate trace records.

### **WSNAME** (*workstation name*)

The name of the workstation to be updated. You must specify this parameter.

The `WSSTAT` parameters are checked for validity and consistency. The validity checks are performed on the tracker where the command is run. The validity check processes parameter names, and length and type of parameter values.

If the input is valid, a *workstation status event* is generated and communicated to the controller. Processing of the event includes a consistency check of the values specified in the parameters. The following consistency checks are made:

- The workstation name exists.
- The alternate workstation exists.
- If the value given in the STATUS parameter is the same as the current status of the workstation, the command is ignored.

### **Example**

### **Examples**

The following two examples show how you can use WSSTAT in TSO, or in a batch job (using the batch program EQQEVPGM).

#### **Example 1 - TSO command**

```
ALLOC F(EQQMLIB) DA('OPC.MESSAGE.LIBRARY') SHR REUSE
WSSTAT SUBSYS(OPCB) WSNAME(AS4H) STATUS(O) START(R)
```

In this example, the status of workstation AS4H is set to OFFLINE. Started operations are restarted on the alternate workstation.

**Example 2 - Batch job**

```
//CHSTATUS JOB (ACCOUNT),'Change WS status',CLASS=A
//STEP1 EXEC PGM=EQQEVPGM
//STEPLIB DD DSN=OPC.LOAD.MODULE.LIBRARY,DISP=SHR
//EQQLIB DD DSN=OPC.MESSAGE.LIBRARY,DISP=SHR
//EQQMLOG DD SYSOUT=A
//SYSIN DD *
WSSTAT SUBSYS(OPCB) WSNAME(AS4H) STATUS(A)
/*
```

In this example, the status of workstation AS4H is set to ACTIVE.

## Browsing system information of IBM Z Workload Scheduler Agent workstations

You can view the system information of an IBM Z Workload Scheduler Agent workstation by entering the I row command in the following panels:

- Modifying Workstations in the Current® Plan (EQQMWSLL)
- Browsing Summary of Activities at a Workstation (EQQSWSSP)

Figure 9: EQQSWIZC - Browsing an IBM Z Workload Scheduler Agent workstation system information on page 61 shows what type of information is provided in the panel.

**Example**

Figure 9. EQQSWIZC - Browsing an IBM Z Workload Scheduler Agent workstation system information

```
EQQSWIZC ----- BROWSING Z-CENTRIC SYSTEM INFORMATION -----
Command ==>

Work station      : LWE1           Accts Receivable
Destination      : ITAAC1          HTTP
Code page        : IBM-037
Hostname         : AR11.ZAPHOD.COM
Port number      : 44112

System Information:
Operating system name : WINDOWS
Operating system level:
Agent version        : 8.6
Agent fixpack level  : 0

Default JOBREC values
JOBUSR      : user01
JOBPWD      : Y
JOBTYPE     : accessmeth1

User name
Password (Y/N/A)
Access Method
```

## Chapter 6. Defining and managing dynamic workstations

When you add dynamic capabilities to your environment, you can schedule your workload dynamically.

You can add dynamic capabilities to your environment by connecting the Z controller to a dynamic domain manager. The dynamic domain manager is installed in the distributed environment and manages IBM Z Workload Scheduler Agents with dynamic capabilities, also installed in the distributed environment.

The type of dynamic capabilities you add to your IBM Workload Scheduler agents depends on the type of workload you plan to run:

- If you plan to run existing IBM Workload Scheduler jobs dynamically, install the IBM Z Workload Scheduler Agents with dynamic capabilities and connect the agents to a dynamic domain manager connected to an IBM Z Workload Scheduler controller.
- If you plan to run both existing IBM Workload Scheduler jobs and job types with advanced options dynamically, install the IBM Z Workload Scheduler Agents with dynamic capabilities and Java™ run time and connect the agents to a dynamic domain manager connected to an IBM Z Workload Scheduler controller.

In the z/OS® environment, you can have the following dynamic workstations:

### **Broker**

Also known as dynamic domain manager in the distributed environment. An installed component in an IBM Workload Scheduler distributed or z/OS® network that is the management hub in a domain where you run both static and dynamic workload. All communications to and from the dynamic agents in the domain are routed through the dynamic domain manager. You can use this workstation to submit jobs by reference. You can define the broker workstation either from ISPF panels or from the Dynamic Workload Console. For more information, see *IBM Workload Scheduler: Planning and Installation*.

### **Pool**

A workstation that groups a set of IBM Z Workload Scheduler Agents with dynamic capabilities that have similar hardware or software characteristics to submit jobs to. IBM Workload Scheduler balances the jobs among the IBM Z Workload Scheduler Agents with dynamic capabilities within the pool and automatically reassigns jobs to available agents if an agent is no longer available. To create a pool of IBM Z Workload Scheduler Agents with dynamic capabilities, define a workstation of type pool hosted by the workload broker workstation, then select the IBM Z Workload Scheduler Agents with dynamic capabilities you want to add to the pool. You can define the pool only using the Dynamic Workload Console.

### **Dynamic pool**

A workstation that groups a set of IBM Z Workload Scheduler Agents with dynamic capabilities, which is dynamically defined based on the resource requirements you specify. For example, if you require a workstation with low CPU usage and Windows™ installed to run your job, you specify these requirements using the Dynamic Workload Console. This workstation maps all the IBM Z Workload Scheduler Agents with dynamic capabilities in your environment that meet the requirements you specified. The resulting pool is dynamically updated

whenever a new suitable IBM Z Workload Scheduler Agent with dynamic capabilities becomes available. You can define the dynamic pool only using the Dynamic Workload Console.



**Note:** For these types of workstations, the WSOFFLINE keyword of the JTOPTS initialization statement of the controller is forced to the LEAVE value.

To enable dynamic end-to-end communication, perform the following steps:

1. Install the dynamic domain manager in the distributed environment. For more information, see *IBM Workload Scheduler: Planning and Installation*.
2. Establish a connection between the Z controller and the dynamic domain manager: in the ROUTOPTS statement, set the DESTINATION keyword to the host name of the dynamic domain manager previously installed, in the following format:

```
DESTINATION NAME=DDM_hostname/DDM:port_number/B
```

3. Define the dynamic domain manager workstation. Depending on how you plan to use the dynamic domain manager, the procedure varies:

#### Submission of jobs by reference

Define the dynamic domain manager using the following ISPF panels:

- a. CREATING GENERAL INFORMATION ABOUT A WORKSTATION
- b. WORKSTATION END-TO-END OPTIONS

For more information, see [Creating broker workstations on page 63](#).

#### Dynamic submission of jobs to pools and dynamic pools

Define the dynamic domain manager in the Dynamic Workload Console using the **Create Workstations** panel. For more information, see [Creating pools and dynamic pools on page 65](#).

4. Install the IBM Z Workload Scheduler Agents with dynamic capabilities.
5. *Optionally*, define the pools and dynamic pools in the distributed environment using the Dynamic Workload Console.

To schedule jobs from IBM® Z Workload Scheduler to a distributed environment, you have the following options:

- Submission to pools and dynamic pools. For more information, see [Submitting jobs to pools or dynamic pools on page 65](#).
- Submission of jobs defined on the dynamic domain manager. For more information, see [Submitting jobs by reference on page 66](#).

## Creating broker workstations

Create broker workstations using the ISPF panels and the Dynamic Workload Console.

You can use broker workstations to submit jobs by reference, as explained in [Submitting jobs by reference on page 66](#). To define a broker workstation, perform the following steps:

1. Define a broker workstation as a computer automatic workstation, as described in [Figure 10: EQQWCGEP - Creating general information about a broker workstation on page 64](#) and enter the destination name previously defined in the ROUTOPTS statement. The DYNAMIC option excludes all other options.

Figure 10. EQQWCGEP - Creating general information about a broker workstation

```

EQQWCGEP ----- CREATING GENERAL INFORMATION ABOUT A WORK STATION -----
Command ==>

Enter the command R for resources or A for availability or 0 for end-to-end
options, or enter/change data below:

WORK STATION NAME   ==> DYNW
DESCRIPTION         ==> dynamic workstation_____
WORK STATION TYPE   ==> C           G General, C Computer, P Printer
                                R Remote Engine
REPORTING ATTR      ==> A           A Automatic, S Manual start and completion
                                C Completion only, N Non reporting
PRINTOUT ROUTING    ==> SYSPRINT   The ddname of daily plan printout data set
SERVER USAGE        ==> B           Parallel server usage, B, N, P, or C
DESTINATION         ==> ITAAC1     Name of destination
Options: allowed Y or N
SPLITTABLE          ==> N           JOB SETUP           ==> N
STARTED TASK, STC   ==> N           WTO                 ==> N
AUTOMATION          ==> N           Z-CENTRIC AGENT     ==> N
WAIT                ==> N           DYNAMIC             ==> Y
VIRTUAL             ==> N
REMOTE ENGINE TYPE  ==>           Z z/OS or D Distributed

Defaults:
TRANSPORT TIME      ==> 00.00       Time from previous work station HH.MM
DURATION            ==> 00.05.00    Duration for a normal operation HH.MM.SS

```

2. Select 0 to open the WORK STATION END-TO-END OPTIONS panel.
3. Select BROKER=Y.

Figure 11. EQQWCEOD - Defining end-to-end options

```

EQQWCEOD ----- WORK STATION END-TO-END OPTIONS-----
Command ==>

Enter/change data below:

WORK STATION NAME   ==> BRK

Default JOBREC values on this workstation:
JOBUSER             ==>                               User name
JOBPWD              ==>                               Password (Y/N/A)
JOBTYP              ==>                               Access method

Dynamic options:
BROKER              ==> Y

```

For more information, see the section about creating workstations in *IBM Z Workload Scheduler: Managing the Workload*.

## Defining a backup dynamic domain manager

How you can define a backup dynamic domain manager.

To define a backup dynamic domain manager, perform the following steps:



1. Install the backup dynamic domain manager in the distributed environment. For more information, see *IBM Workload Scheduler: Planning and Installation*.
2. Establish a connection between the Z controller and the backup dynamic domain manager: in the ROUTOPTS statement, set the DESTINATION keyword to the host name of the backup dynamic domain manager previously installed, in the following format:

```
DESTINATION NAME=backup_DDM_hostname/backup_DDM:port_number/B
```

3. Define a dynamic workstation with type broker.
4. Define the dynamic workstation as alternate workstation of the workstation corresponding to the dynamic domain manager, the pool, and the dynamic pool.

You do not need to define pools and dynamic pools associated to the backup dynamic domain manager. When the dynamic domain manager fails and the backup dynamic domain manager takes over, the backup dynamic domain manager automatically inherits the dynamic agents, pools, and dynamic pools defined on the dynamic domain manager.

## Creating pools and dynamic pools

You can create pools and dynamic pools using the Dynamic Workload Console.

To create pools and dynamic pools using the Dynamic Workload Console, perform the following steps:

1. In the Z controller, define the ROUTOPTS statement by setting the DESTINATION parameter to the host name of the dynamic domain manager. For detailed information about ROUTOPTS, see *Customization and Tuning*.
2. From the Dynamic Workload Console.
3. Click **Design > Workload Designer**.
4. Select a z/OS® engine from the list and click **Create new > Workstation**.
5. Select **Pool** as the category of workstation you want to create.
6. In the properties pane, specify the workstation attributes in the **General Info**, **Resources**, and **Defaults** tabs. Depending on the type of workstation you select, some attributes are required.
7. Click **Save**.

For more information about workstation characteristics and attributes, see the Dynamic Workload Console online help.

## Submitting jobs to pools or dynamic pools

### About this task

To submit jobs to a pool or dynamic pool, perform the following steps:

1. Define a [JOBREC on page 74](#) statement using the appropriate syntax, as explained in [Defining a job in the JOBLIB data set on page 73](#). Alternatively, you can create the job from the Dynamic Workload Console.
2. Submit the JOBREC statement to the workstation defined in [Creating pools and dynamic pools on page 65](#). The job is submitted to the workstation you specified. IBM Workload Scheduler dynamically assigns the job to the best available resource.

## Submitting jobs by reference

### About this task

When you submit a job by reference, you create a job definition in the distributed environment and submit it from IBM® Z Workload Scheduler to the distributed environment. In the distributed environment, the job is dynamically assigned to the best available resource. You write in the IBM® Z Workload Scheduler JCL only the job name of the job, without having to write or import the whole job into the JCL. You can submit jobs by reference only on broker workstations.

To submit jobs by reference from IBM® Z Workload Scheduler, perform the following steps:

1. Define a job with name **broker\_test** by using the Dynamic Workload Console. This job contains the operations to be performed:
2. Create a JCL, by using the ISPF panels or the Dynamic Workload Console, specifying the name of the job you created in step 1. This references the job in the distributed environment.
3. Submit the JCL. As a result, the **broker\_test** job is submitted in the distributed environment.

# Chapter 7. Setting the security features

IBM Z Workload Scheduler provides a secure, authenticated, and encrypted connection mechanism for communicating across the network. This mechanism is based on the Secure Sockets Layer (SSL) protocol.

By default, the IBM Z Workload Scheduler Agent is installed with the SSL protocol enabled. According to this default, in the HTTPOPTS statement you must set the connection security for end-to-end communication to enable SSL.

According to the certificates that you are using (USS or SAF) to enable the SSL communication see the relevant section:

- [Customizing the SSL connection with the Z controller when using your certificates \(SAF\) on page 67](#)
- [Customizing the SSL connection with the Z controller when using your certificates \(USS\) on page 70](#)

## Customizing the SSL connection with the Z controller when using your certificates (SAF)

The management of security certificates is different between product versions. Depending on the z-centric agent version you are using, customize the SSL connection between the agent and Z controller by either using your SAF certificates or the default certificates.

### About this task

Depending on the agent version that you are using:

#### For an agent version 10.2.1, or later

Customize the Z controller by using the SAF (System authorization facility) interface, the agent certificates and the configuration file. For more information, see [Customizing the SSL connection between the agents and Z controller when using your certificates on page 67](#).

#### For an agent version 10.2.0, or earlier

You can either use default certificates or create your own. For more information, see [Setting SSL-secure connections for communication using the default certificates on page 69](#).

## Customizing the SSL connection between the agents and Z controller when using your certificates

### About this task

To communicate, the IBM Z Workload Scheduler Agents (z-centric agents) and the Z controller use the HTTPS protocol. The communication process uses the certificates obtained by customizing the Z controller using the SAF (System authorization facility) interface. In addition to customizing those certificates, you need to customize the agent certificates and the configuration file. To enable SSL communication, perform the following steps.

1. Generate the distributed certificates for the agent. Consider the following example commands:

```
° openssl genrsa -out ca.key 4096
° openssl req -x509 -new -nodes -key ca.key -subj "/CN=<common_name>" -days 3650 -out ca.crt
° openssl genrsa -des3 -out tls.key 4096
° openssl req -new -key tls.key -out tls.csr
° openssl x509 -req -in tls.csr -CA ca.crt -CAkey ca.key -CAcreateserial -out tls.crt -extfile /etc/
  pki/tls/openssl.cnf -extensions v3_req
```

2. Store the resulting `ca.crt`, `tls.crt`, and `tls.key` files on the agent in a folder of your choice. When running the `twinsinst` script to install the agent, specify that folder with the **sslkeysfolder** parameter.

3. Generate a z/OS certificate as follows:

- Create a z/OS certificate and save it with the `.crt` extension.
- Export the certificate in ASCII mode to the distributed environment.
- On the workstation where you plan to install the agent, create a folder named `additionalCAs` nested in the folder where you previously stored the distributed certificates created in [step 2 on page 68](#).
- Store the certificate in the `additionalCAs` folder. The `additionalCAs` folder must also contain the public key certificate or public certificate chain of the Z controller SSL key ring.

4. Import the distributed certificates (`ca.crt` and `tls.crt`) in the z/OS environment in ASCII mode.

5. Install the agent by running the `twinsinst` script and specifying the `sslkeysfolder` and `sslpassword` parameters.

Consider the following example:

```
./twinsinst -new -uname <agent_name> -acceptlicense yes
-addjruntime true -inst_dir <inst_dir> -jimport xxxxx -jimportssl true -sslkeysfolder <path_to_distr_cert>
-sslpassword <keystore_password>
```

where:

**new**

A fresh installation of the agent.

**uname**

Name of the user for which the agent is being installed.

**acceptlicense**

Whether to accept the License Agreement.

**addjruntime**

Adds the Java™ run time to run job types with advanced options, both those types that are supplied with the product and the additional types that are implemented through the custom plug-ins.

**inst\_dir**

Folder of the agent installation.

**jimport**

JobManager port number used by the Z controller to connect to the agent.

**jimportssl**

JobManager port used by the Z controller to connect to the agent. Supported values are `true` and `false`.

**sslkeysfolder**

Name and path of the folder on the agent containing certificates. The folder must contain the following items:

- ca.crt
- tls.crt
- tls.key
- additionalCAs folder

**sslpassword**

Password to access the certificates.

**Results**

The agent is now completely configured.

**Setting SSL-secure connections for communication using the default certificates****About this task**

To provide SSL security for an HTTP connection between the Z controller and HCL Workload Automation Agent, set the HTTPS keyword in the in the ROUTOPTS statement. For details about ROUTOPTS, see *Customization and Tuning* statement.

At installation time, the default security certificates are automatically stored in the SEQQDATA library:

**EQQCERCL**

The security certificate for the client.

**EQQCERSR**

The security certificate for the server.

You can decide to use these default certificates or create your own. However, in a production environment, it is recommended that you customize SSL communication with your own certificates.

In both cases, you need to import them into your security system. If you are using RACF, you are provided with the EQQCERT sample job that you can run to import the certificates. To run this job, ensure that you use the same user ID that RACF associates with the controller started task.

The EQQCERT job:

- Copies the EQQCERCL certificate to a temporary sequential data set
- Copies the EQQCERSR certificate to a temporary sequential data set
- Imports EQQCERCL to RACF
- Imports EQQCERSR to RACF
- Deletes the temporary sequential data sets
- Creates the SAF key ring that is used to connect the imported certificates
- Updates the RACF database with the new certificates and key ring

## Customizing the SSL connection with the Z controller when using your certificates (USS)

### About this task

To communicate, the z-centric agents and Z controller use the HTTPS protocol. The communication process uses the certificates obtained by customizing the Z controller certificates with the USS (UNIX System Services) component. In addition to customizing those certificates, you need to customize the agent certificates and the configuration file. To enable SSL communication, perform the following steps:

1. Generate a `.kdb` CMS key store file. This file must contain a private key trusted by the Z controller to which the agent is registered, and the Z controller public key to allow the agent to trust it.
2. Save the password of the key store in a stash file that has the same name as the file that you generated in step 1 on [page 70](#) and give it extension `.sth`.
3. Edit the `ita.ini` agent configuration file by setting the following properties to the values specific for your environment:

```
cert_label=<label_agent_private_key>
key_db_name=<file_name>
key_repository_dir=<directory>
tcp_port=0
ssl_port=<ssl_port_value>
verify_cn_string=<common_name>
```

Where:

#### **label\_agent\_private\_key**

Label of the agent private key that you want to use to communicate. The default is **client**.

#### **file\_name**

Name of the file, without its extension. The default value is **TWSClientKeyStore**.

#### **directory**

Name of the directory that contains the files generated in step 1 on [page 70](#) and in step 2 on [page 70](#). The default path is `/opt/IBM/TWA_<TWS_user>/TWS/ITA/cpa/ita/cert`.

#### **tcp\_port\_value**

TCP/IP port value. Specify **0**.

#### **ssl\_port\_value**

Same as `tcp_port_value`.

#### **common\_name**

IBM® Z Workload Scheduler checks the validity of the certificate and verifies that the peer certificate has been issued by a recognized CA. If you set the `verify_cn_string` parameter, IBM® Z Workload Scheduler verifies that the Common Name (CN) of the Certificate Subject matches the `common_name` that you set in this parameter.

This setting is valid for both dynamic and z-centric agents. To make the changes effective, you must restart the agent.

To configure the TLS v1.2 connection, in the `ita.ini` file add the following properties to the [ITA SSL] section:

```
sslv3_cipher = NONE
tls10_cipher = NONE
tls11_cipher = NONE
tls12_cipher = DFLT
```

#### 4. Stop the agent:

```
ShutDownLwa
```

#### 5. Restart the agent:

```
StartUpLwa
```

After you complete the procedure, depending on the SSL storing certificate method you use, import the certificates in a RACF KEYRING or in a keystore created in the UNIX System Services. Depending on the method you use refer either to the RACF or the Unix System Services documentation.

## Enabling FIPS compliance over IBM Z Workload Scheduler server SSL secured connection

Federal Information Processing Standard Security Requirements for Cryptographic Modules, referred to as FIPS 140-2, is a standard published by the National Institute of Standards and Technology (NIST). Organizations can require compliance to the FIPS 140-2 standard to provide protection for sensitive or valuable data to cryptographic-based security systems.

System SSL was designed to meet the Federal Information Processing Standard - FIPS 140-2 Level 1 criteria.

System SSL can run in either "FIPS mode" or "non-FIPS mode". By default, System SSL runs in "non-FIPS" mode.

IBM Z Workload Scheduler uses the System SSL configuration. To run IBM Z Workload Scheduler in "FIPS mode", you must enable FIPS compliance over System SSL connections.

To implement FIPS 140-2 Level 1 standards perform the following actions:

1. Ensure that FIPS-compliance over a SSL connection is enabled on the controller, as described in *IBM z/OS Cryptographic Services System Secure Sockets Layer Programming manual, Chapter 4. System SSL and FIPS 140-2*.
2. On the controller, set ENABLEFIPS to YES in the HTTPOPTS initialization statement. For more information about HTTPOPTS, see *Customization and Tuning*.
3. On the z-centric agent, ensure that the FIPS-compliance is enabled. For more information about how to configure SSL to be FIPS-compliant, see the *IBM Workload Scheduler: Administration Guide*.
4. On the z-centric agent ensure that:
  - SSL is configured, as described in [Customizing the SSL connection with the Z controller when using your certificates \(USS\) on page 70](#)
  - In the `ita.ini` file, the `ssl_port` is set and `fips_enable = 1`.

## Encrypting the user password

You define user IDs and passwords for Windows™ users by using the `USRREC` statement in a `PARMLIB` member (the default member name is `USRINFO`). For details, see *Customization and Tuning*.

To encrypt the user password, run the sample provided in the `EQQBENCR` member of the `EQQSAMP` library.



## Chapter 8. Defining and managing jobs

How to define and manage jobs within the z-centric end-to-end scheduling solution.

### Defining a job from the Dynamic Workload Console

How to define a new job definition using the Dynamic Workload Console.

#### About this task

From the Workload Designer, panel of the Dynamic Workload Console you can define multiple types of jobs, running on both distributed and z/OS environments. Some predefined job types are organized into categories including native jobs, and job types with advanced options, which are specific job types that you use to perform operations on external applications. In addition to the existing ones, you can define your own job types and add them to this list. Starting with IBM® Z Workload Scheduler version 8.6, it is possible to create JOBLIB members containing z-centric job types using the Dynamic Workload Console. These jobs leverage the job type plug-ins that are included in the z-centric agent Java™ extensions.

These jobs created using the Dynamic Workload Console are saved in XML format in the EQQJBLIB and should not be edited directly. If they need to be modified, changes are to be made by using the Dynamic Workload Console.

Also, if a user ID is provided in the job definition, it is not possible to modify the user using either the IBM® Z Workload Scheduler user exit EQQUX001 or the workstation end-to-end options. Only the user specified when the job is defined from the Dynamic Workload Console will be considered when the job runs.

Many of the old plug-ins previously provided with the product are now out-of-the-box integrations available on [Automation Hub](#), together with the related documentation. In addition to these job plug-ins, new integrations to extend your automation processes are constantly added to [Automation Hub](#). For an up-to-date list of all available integrations, visit the [Automation Hub](#) site.

To create a new job definition from the Dynamic Workload Console, perform the following procedure:

1. From the Dynamic Workload Console portfolio, click **Design >Workload Designer**.
2. Specify a z/OS engine name.
3. Click **Create new >Job**.
4. Select the type of job you want to create.
5. In the properties panel, specify the attributes for the job definition you are creating. For all the details about available fields and options, see the online help by clicking the "?" on the top-right corner.
6. Click **Save** to save the job definition in the database.

### Defining a job in the JOBLIB data set

You define the jobs to be run on IBM Z Workload Scheduler Agent workstations in a job definition member of the JOBLIB data set. In the JOBLIB member, you can either define the job contents or invoke a script or an executable that is stored locally on the IBM Z Workload Scheduler Agent workstation.

If you do not specify any content in the job definition member, the error code JCLI is issued.

To define the job contents, the following syntax rules apply:

- The lines that start with `/* OPC`, `/*%OPC`, or `/*>OPC` are used for variable substitution and automatic recovery. They are removed before the script is downloaded onto the IBM Z Workload Scheduler Agent.
- Each line starts between column 1 and column 80.
- The last backslash (`\`) in a line is considered the character of continuation.
- Blanks at the end of the line are automatically removed.

To define the job properties, use the [JOBREC on page 74](#) statement. In the [JOBREC on page 74](#) statement, you can define different job types.

## JOBREC

To define the properties of a job to be run on IBM Z Workload Scheduler Agent workstations, use the following format:

```
//JOBREC
keyword(value)
keyword(value)
//END JOBREC
```

The following syntax rules apply:

- The value of each keyword can continue over one or more lines.
- Each statement must be on a separate line.
- The value of each keyword must be enclosed within parentheses. This means that every character enclosed within the parentheses is considered to be part of the keyword value, including blanks and single quotes.
- The script or executable must follow the `//END JOBREC` line.
- If you specify the same keyword more than once, only the last keyword specified is considered valid.
- You can insert any comment text by using `/*` as the starting characters.
- Unsupported keywords inserted in the statement are ignored without warning.
- Keywords are optional, unless otherwise indicated.
- Keywords and values are case-sensitive.



**Note:** When the job is defined using a `JOBREC` and specifying the `JOBTYP` keyword, or when it is defined using the Dynamic Workload Console, any `USERID` specified in the job definition is not used as the user under which the job runs on the z-centric agent. Rather, the specified `USERID` is needed to perform logon to the remote back end processes, such as, database servers or web servers, with which the job must interact.

In contrast, with native z-centric jobs defined directly in the `EQQJBLIB` without any `JOBREC`, or with a `JOBREC` but without the `JOBTYP` keyword, the `USERID` provided by the `JOBUSER` keyword of the `JOBREC`, or by `EQQUX001`, is used by the z-centric agent as the ID under which it submits the job on the server where the agent runs.



JOBREC is supported by z-centric agent (IBM Z Workload Scheduler Agent) on IBM i systems, provided that you set `RunExecutableAsIBMiJobs=true` in the `JobManager.ini` file.

In the JOBREC statement, you can define different job types.

Supported job types and their related keywords are listed in [Table 3: Jobs and their keywords on page 75](#).

**Table 3. Jobs and their keywords**

Job to be run	Keywords	Section
database	DBNAME (required) DBTYPE (required) JOBTYP (required) PORT (required) SERVER (required) STATEMENT( <i>id</i> ) (required) CMDTYPE( <i>id</i> ) (optional) JOBPWD (optional) JOBUSR (optional) POLLINGIVL( <i>id</i> ) (optional, applies only to the MSSQL database type) SYNCTYPE( <i>id</i> ) (optional, applies only to the MSSQL database type) WSNAME (optional)	<a href="#">Syntax diagram for database job types on page 76</a>
file transfer	JOBPWD (required) JOBTYP (required) JOBUSR (required) LOCALFILE (required) TRANSFERTYPE (required) APPENDTEXT (optional) DELETEAFTERDOWNLOAD (optional) DELETEAFTERUPLOAD (optional) EXTRACOMMANDS (optional) LOCALCODEPAGE (optional) LOCALPWD (optional) LOCALUSR (optional) MAXPORT (optional) MINPORT (optional) PASSIVEMODE (optional) PROTOCOL (optional) REMOTECODEPAGE (optional) REMOTEFIL (required)	<a href="#">Syntax diagram for file transfer job types on page 84</a>

**Table 3. Jobs and their keywords (continued)**

Job to be run	Keywords	Section
	SERVER (required) TIMEOUT (optional) TRANSFERMODE (optional)	
web service	JOBTYPE (required) OPNAME (required) URL (required) JOBPWD (optional) JOBUSR (optional) PARM( <i>id</i> ) (optional) WSNAME (optional)	<a href="#">Syntax diagram for web service job types on page 90</a>
java	CLASSNAME (required) JOBTYPE (required) JARPATH (optional) JAVAPARM( <i>id</i> ) (optional)	<a href="#">Syntax diagram for Java job type on page 92</a>
xajob	JOBTYPE (required) ENVVAR( <i>id</i> ) (optional) JOBPWD (optional) JOBUSR (optional) WSNAME (optional)	<a href="#">Syntax diagram for xajob job type on page 94</a>
j2ee jms	CONNFACTORY (required) DESTINATION (required) JOBTYPE (required) AUTHALIAS (optional) INVOKEYTYPE (optional) JOBPWD (optional) JOBUSR (optional) MESSAGE (optional) WSNAME (optional)	<a href="#">Syntax diagram for J2EE jms job type on page 96</a>

## Syntax diagram for database job types

The database job type:

If you set JOBTYPE to `(/database)`, you can choose among the following database types:

- DB2@
- Oracle
- MSSQL

The syntax for DB2® and Oracle is identical, but the syntax for MSSQL supports MSSQL-specific operations. For details, see [Syntax diagram for DB2 and Oracle database job types on page 77](#) and [Syntax diagram for MSSQL database job type on page 80](#).

## Syntax diagram for DB2® and Oracle database job types

### Purpose

Syntax diagram for the DB2® and Oracle database job types. The following syntax rules apply:

- You can define multiple statements in the same job by specifying a series of `STATEMENTid` keywords, where `id` is a unique numeric value, including null and zero. For example, you can define `STATEMENT`, `STATEMENT0`, `STATEMENT1`, `STATEMENT2`, and so on.
- If you set `DBTYPE` to `DB2` or `Oracle`, you can set `CMDTYPE` to `SQL`.
- You can specify any number of `CMDTYPE` keywords, according to the corresponding `STATEMENT` keyword. The `STATEMENT` keyword must be specified before the corresponding `CMDTYPE` keyword. For example, you can specify `CMDTYPE3` only if you have previously specified `STATEMENT3`.

### Format

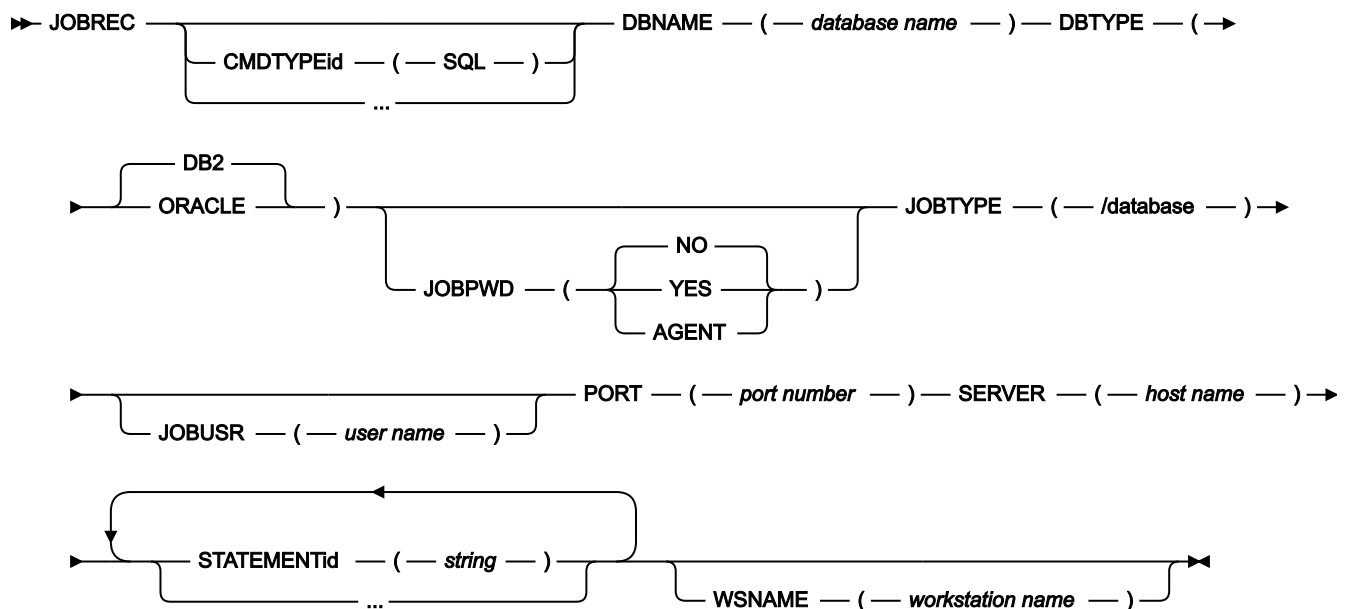

### Parameters

#### CMDTYPEid(SQL)

The type of command to be run. You can specify a series of `CMDTYPEid` keywords, where `id` is a unique numeric value, including null and zero. The `id` of the `CMDTYPE` keyword must match the `id` of the related `STATEMENT` keyword. For example, you can specify `CMDTYPE3` only if you specify `STATEMENT3`.

If you set `DBTYPE` to `(/DB2)` or to `(/ORACLE)`, you can set `CMDTYPE` to `SQL`.

**DBNAME(database name)**

The name of the database. This keyword is required.

**DBTYPE(DB2|ORACLE)**

The database type. This keyword is required.

**JOBPWD(YES|NO|AGENT)**

Specifies if the user name entered in `JOBUSR` or set by using the job-submit exit `EQQUX001` is associated with a password.

If you set `JOBPWD` to `YES`, IBM Z Workload Scheduler searches for the user password in the `USRPSW` keyword of the `USRREC` statement (for details, see *IBM Z Workload Scheduler: Customization and Tuning*).

If you set `JOBPWD` to `AGENT`, this means that the password is resolved locally on the agent. The password must have been defined on the agent by means of the [param on page 48](#) command. This feature is available independently of the operating system of the workstation.

Typically, the password is required for users who schedule jobs to run on Windows™ workstations. Set `JOBPWD` to `NO` if the user works with UNIX™ workstations and if no password is required.

**JOBTYPE(/xajob/access method name/j2ee/jms/web service/file transfer/database/java)**

To run a database job, specify `/database`. For information about the other types of job, see the specific section for each job type. This keyword is required.

**/database**

Set this value to submit a database job. Before you can run a query on a database, download the JDBC drivers for your database client to each IBM Z Workload Scheduler Agent on which you want to submit database jobs. Specify the path to the database client jar files in the `DatabaseJobExecutor.properties` file, located in the `JavaExt\cfg` directory in your IBM Workload Scheduler installation directory. Define the `jdbcdDriversPath` property to point to the JDBC jar files directory, for example, `jdbcdDriversPath=c:\\mydir\\jars\\jdbc`. The JDBC jar files must be located in the specified directory or its subdirectories. Ensure that you have list permissions for the directory and its subdirectories.

**JOBUSR(user name)**

The user name for accessing the database.

If the user schedules jobs to run on Windows™ workstations, ensure that a user password is also defined (see the `JOBPWD` keyword).

- If you are defining a Windows™ domain user, use the following format:

```
JOBUSR (domainName\user1)
```

- If you are defining a Windows™ user in the `username@internet_domain` format, use the following format:

```
JOBUSR ('administrator@mywindow.com')
```

To specify the user name, you can also use the job-submit exit EQQUX001. This user name overrides the value specified for JOBUSR. In turn, the value specified for JOBUSR overrides the value specified for USRRAM in the USRREC statement.

### **PORT**(*port number*)

The port number for the database job. This keyword is required.

### **SERVER**(*host name*)

The host name of the server where the file transfer is to be performed or where the database is located. This keyword is required if you set JOBTYP to `(/file transfer)` or to `(/database)`.

### **STATEMENT***id*(*string*)

The string defining the SQL query or job. This keyword is required. You can define multiple statements in the same job by specifying a series of STATEMENT*id* keywords, where *id* is a unique numeric value, including null and zero. For example, you can define STATEMENT, STATEMENT0, STATEMENT1, STATEMENT2, and so on.

When running stored procedures, ensure that the returned result is in tabular format. Results in any other format are not supported.

### **WSNAME**(*workstation\_name*)

The name of the workstation from which user name and password must be retrieved. User name and password can be specified in the statement, using the JOBUSR and JOBPWD keywords, or can be associated to a workstation with the USRREC statement. With the WSNAME keyword, you can specify a workstation where the user name and password are stored, which is different from the workstation where the job runs.

## **Example**

### **Examples**

The following is an example of a JOBTYP statement to select all records from table SYSTOOLS.POLICY:

```
//JOBTYP
JOBTYP(/database)
STATEMENT20(SELECT * FROM SYSTOOLS.POLICY)
DBNAME(DBWEB)
DBTYPE(DB2)
SERVER(9.168.99.87)
PORT(50000)
JOBUSR(Administrator)
JOBPWD(YES)
CMDTYPE20(SQL)
//END JOBTYP
```

The following is an example of a JOBTYP statement to select columns country\_id and country\_name FROM table countries:

```
//JOBTYP
JOBTYP(/database)
STATEMENT1(SELECT country_id, country_name FROM countries)
DBNAME(SAMPLE)
DBTYPE(ORACLE)
SERVER(9.168.115.37)
```

```

PORT(70000)
CMDTYPE1(SQL)
JOBUSR(ZCENTUMB)
JOBPWD(YES)
//END JOBREC

```

## Syntax diagram for MSSQL database job type

### Purpose

This section provides detailed information about the syntax diagram for the MSSQL database job type. The following syntax rules apply:

- You can define multiple statements in the same job by specifying a series of `STATEMENT $id$`  keywords, where  $id$  is a unique numeric value, including null and zero. For example, you can define `STATEMENT`, `STATEMENT0`, `STATEMENT1`, `STATEMENT2`, and so on.
- If you set `DBTYPE` to `(/MSSQL)`, you can set `CMDTYPE` to either `JOB` or `SQL` and specify the related job or SQL query in the `STATEMENT` keyword. If you set `CMDTYPE` to `JOB`, you can specify a job saved on the server; if you set `CMDTYPE` to `SQL`, you can specify a statement in the native language of the database that you selected.
- If you set `CMDTYPE` to `JOB`, you can optionally define the `SYNCTYPE` and `POLLINGIVL` keywords. This information is not visible in the syntax diagram.
- If you set `CMDTYPE` to `SQL`, you cannot define the `SYNCTYPE` and `POLLINGIVL` keywords. This information is not visible in the syntax diagram.
- You can specify any number of `CMDTYPE`, `SYNCTYPE`, and `POLLINGIVL` keywords, according to the corresponding `STATEMENT` keyword. The `STATEMENT` keyword must be specified before the corresponding `CMDTYPE`, `SYNCTYPE`, and `POLLINGIVL` keywords. For example, you can specify `CMDTYPE3`, `SYNCTYPE3`, and `POLLINGIVL3` only if you have previously specified `STATEMENT3`.



## Format

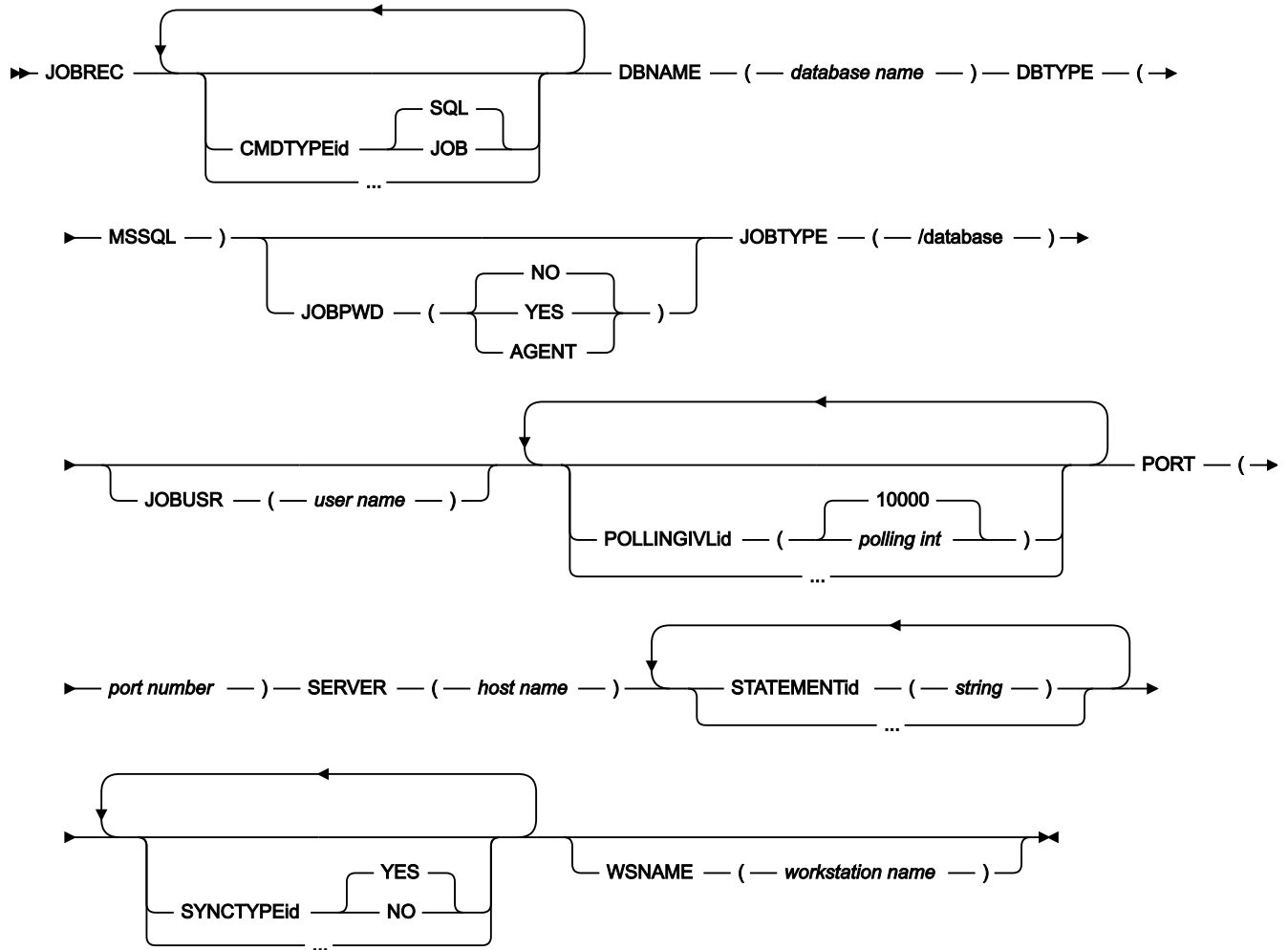

## Parameters

### CMDTYPEid(SQL|JOB)

The type of command to be run. You can specify a series of CMDTYPEid keywords, where *id* is a unique numeric value, including null and zero. The *id* of the CMDTYPE keyword must match the *id* of the related STATEMENT keyword. For example, you can specify CMDTYPE3 only if you specify STATEMENT3.

If you set DBTYPE to (/MSSQL), you can set CMDTYPE to either JOB or SQL and specify the related job or SQL query in the STATEMENT keyword. If you set CMDTYPE to JOB, you can specify a job saved on the server; if you set CMDTYPE to SQL, you can specify a statement in the native language of the database that you selected.

### DBNAME(database name)

The name of the database. This keyword is required.

### DBTYPE(MSSQL)

The database type. This keyword is required.

**JOBPWD(YES|NO|AGENT)**

Specifies if the user name entered in JOBUSR or set by using the job-submit exit EQQUX001 is associated with a password.

If you set JOBPWD to `YES`, IBM Z Workload Scheduler searches for the user password in the USRPSW keyword of the USRREC statement (for details, see *IBM Z Workload Scheduler: Customization and Tuning*).

If you set JOBPWD to `AGENT`, this means that the password is resolved locally on the agent. The password must have been defined on the agent by means of the [param on page 48](#) command. This feature is available independently of the operating system of the workstation.

Typically, the password is required for users who schedule jobs to run on Windows™ workstations. Set JOBPWD to `NO` if the user works with UNIX™ workstations and if no password is required.

**JOBTYP(*/xajob/access method name/j2ee/jms/web service/file transfer/database/java*)**

To run a database job, specify `/database`. For information about the other types of job, see the specific section for each job type. This keyword is required.

**`/database`**

Set this value to submit a database job. Before you can run a query on a database, download the JDBC drivers for your database client to each IBM Z Workload Scheduler Agent on which you want to submit database jobs. Specify the path to the database client jar files in the `DatabaseJobExecutor.properties` file, located in the `JavaExt\cfg` directory in your IBM Workload Scheduler installation directory. Define the `jdbDriversPath` property to point to the JDBC jar files directory, for example, `jdbDriversPath=c:\\mydir\\jars\\jdbc`. The JDBC jar files must be located in the specified directory or its subdirectories. Ensure that you have list permissions for the directory and its subdirectories.

**JOBUSR(*user name*)**

The user name for accessing the database.

If the user schedules jobs to run on Windows™ workstations, ensure that a user password is also defined (see the JOBPWD keyword).

- If you are defining a Windows™ domain user, use the following format:

```
JOBUSR(domainName\user1)
```

- If you are defining a Windows™ user in the `username@internet_domain` format, use the following format:

```
JOBUSR('administrator@mywindow.com')
```

To specify the user name, you can also use the job-submit exit EQQUX001. This user name overrides the value specified for JOBUSR. In turn, the value specified for JOBUSR overrides the value specified for USRNAM in the USRREC statement.

**POLLINGIVL***id*(*polling int*10000)

The polling interval in milliseconds. This keyword is valid only if you set CMDTYPE to (/JOB). You can specify a series of POLLINGIVL*id* keywords, where *id* is a unique numeric value, including null and zero. The *id* of the POLLINGIVL keyword must match the *id* of the related STATEMENT keyword. For example, you can specify POLLINGIVL3 only if you specify STATEMENT3.

**PORT**(*port number*)

The port number for the database job. This keyword is required.

**SERVER**(*host name*)

The host name of the server where the file transfer is to be performed or where the database is located. This keyword is required if you set JOBTYP to (/file transfer) or to (/database).

**STATEMENT***id*(*string*)

The string defining the SQL query or job. This keyword is required. You can define multiple statements in the same job by specifying a series of STATEMENT*id* keywords, where *id* is a unique numeric value, including null and zero. For example, you can define STATEMENT, STATEMENT0, STATEMENT1, STATEMENT2, and so on.

When running stored procedures, ensure that the returned result is in tabular format. Results in any other format are not supported.

**SYNCTYPE***id*(YES|NO)

Specifies if synchronization is required. This keyword is valid only if you set CMDTYPE to (/JOB). You can specify a series of SYNCTYPE*id* keywords, where *id* is a unique numeric value, including null and zero. The *id* of the SYNCTYPE keyword must match the *id* of the related STATEMENT keyword. For example, you can specify SYNCTYPE3 only if you specify STATEMENT3.

**WSNAME**(*workstation\_name*)

The name of the workstation from which user name and password must be retrieved. User name and password can be specified in the statement, using the JOBUSR and JOBPWD keywords, or can be associated to a workstation with the USRREC statement. With the WSNAME keyword, you can specify a workstation where the user name and password are stored, which is different from the workstation where the job runs.

**Example****Examples**

The following is an example of a JOBREC statement to run job SPMTEST\_BACKUP without synchronization and with a polling interval of 100 milliseconds, and to select all records from the DBO.TWSRECORDS table:

```
//JOBREC
JOBTYP(/database)
DBNAME(SCVTEST)
DBTYPE(MSSQL)
SERVER(SQLCON008)
PORT(1278)
STATEMENT1(SPMTEST_BACKUP)
CMDTYPE1(JOB)
```

```
SYNCTYPE1(NO)
POLLINGIVL1(100)
STATEMENT2(SELECT * FROM DBO.TWSRECORDS)
CMDTYPE2(SQL)
JOBUSR(PWR_USER)
JOBPWD(YES)
//END JOBREC
```

## Syntax diagram for file transfer job types

### Purpose

If you set JOBTYP to `(/file transfer)`, you can choose between the following transfer types for transferring binary and text files:

- Upload: Sends a file to a server.
- Download: Downloads a file from a server.

This section provides detailed information about the syntax diagram for both the upload and download transfer types. The following syntax rules apply:

- The syntax of the selected protocol applies.

## Format

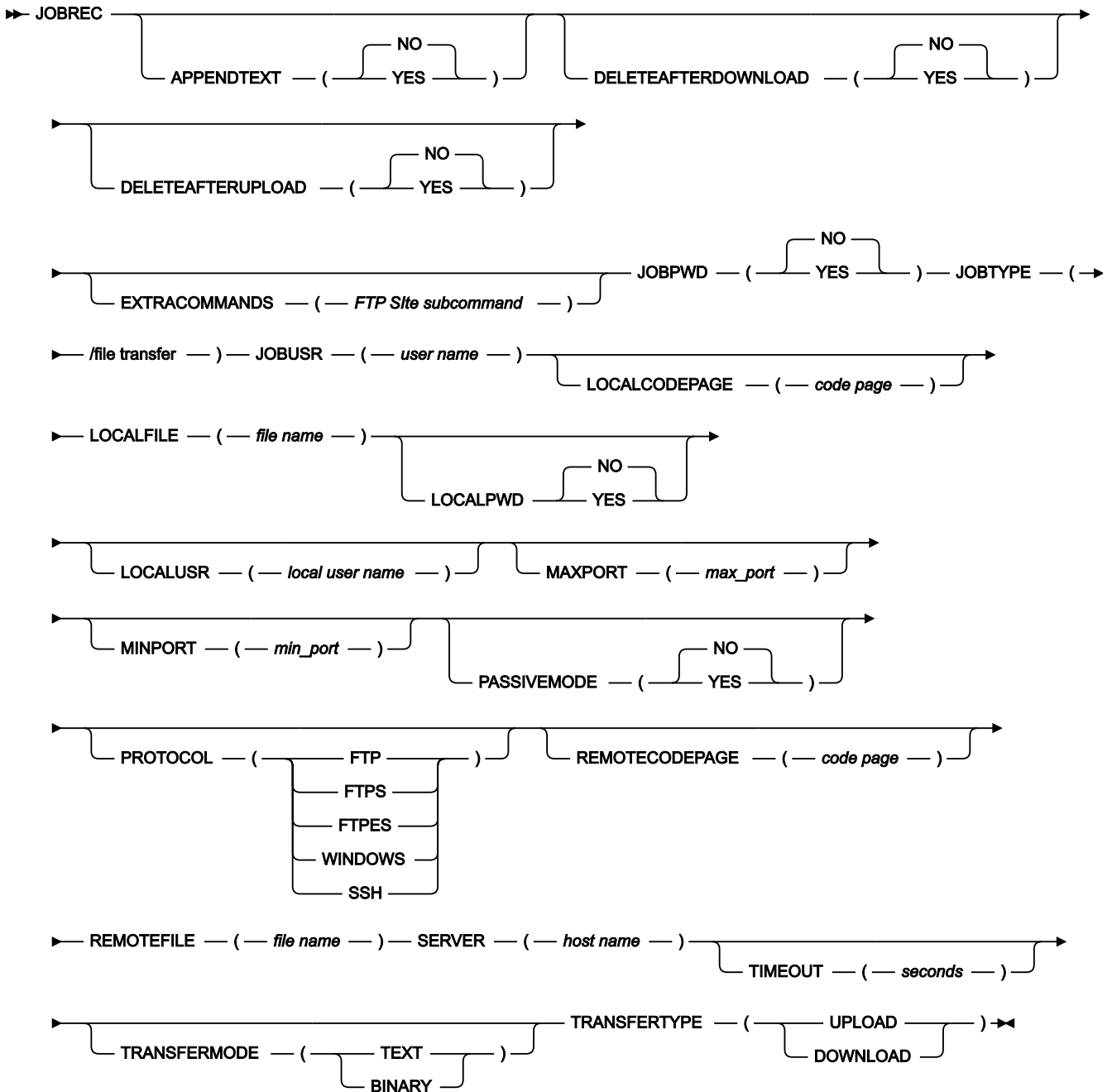

## Parameters

The MINPORT and the MAXPORT options define the port range to use on the client side of TCP data connections. When the active mode is enabled, the MINPORT and the MAXPORT options restrict the port numbers sent by the PORT command. These options are meant to accommodate highly restrictive firewall rules.

If you do not specify the MINPORT and the MAXPORT options, the operating system determines the port numbers to be used. If you specify one of these parameters, the other parameter is required.

#### **APPENDTEXT(YES|NO)**

Specify this attribute and set it to **YES** to append the data contained in the file being transferred to the end of the file on the destination system, if it already exists. If the file does not already exist, it is created. This attribute applies to file transfers of type download and when TRANSFERMODE is set to **TEXT**. Omit this attribute if you do not want to append the data to an existing file. The default value is **NO**.

#### **DELETEAFTERDOWNLOAD(YES|NO)**

Set this attribute to **YES** to delete the transferred files from the server after the download. The default value is **NO**.

#### **DELETEAFTERUPLOAD(YES|NO)**

Set this attribute to **YES** if the source files must be deleted after the transfer. The default value is **NO**.

#### **EXTRACOMMANDS(FTP Site subcommand)**

Specify a Site subcommand to send information that is used by the remote host to provide services specific to that host system. Valid for an upload file transfer using the FTP protocol when the target workstation is a z/OS system. For example, you can specify a subcommand to define how to allocate the data set (LR,BLK, VOL, to name a few).

#### **JOBPWD(YES|NO)**

Specifies that the user name set in JOBUSR or by using the job-submit exit EQQUX001 is associated with a password.

If you set JOBPWD to **YES**, IBM Z Workload Scheduler searches for the user password in the USRPSW keyword of the USRREC statement (for details, see [USRREC on page 45](#)).

Typically, the password is required for users who schedule jobs to run on Windows™ workstations. Set JOBPWD to **NO** if the user works with UNIX™ workstations.

#### **JOBTYP(*/xajob/access method name*|/j2ee/ejb|/j2ee/jms|/web service|/file transfer|/database|/java)**

To run a file transfer job, specify **/file transfer**. For information about the other types of job, see the specific section for each job type. This keyword is required.

##### **/file transfer**

Set this value to submit a file transfer job.

#### **JOBUSR(*user name*)**

The user name for accessing the FTP, FTPS, FTPES, SSH, or Windows™ server.

If the user schedules jobs to run on Windows™ workstations, ensure that a user password is also defined (see the JOBPWD keyword). Use the following syntax:

##### **To define a Windows™ domain user**

```
JOBUSR ( domainName\userName )
```

**To define a Windows™ domain user in the `username@web_domain` format**

```
JOBUSR('userName@web_domain')
```

To specify the user name, you can also use the job-submit exit EQQUX001. This user name overrides the value specified for JOBUSR. In turn, the value specified for JOBUSR overrides the value specified for USRNAM in the USRREC statement.

**LOCALCODEPAGE(*code page*)**

The name of the code page used on the local system. This keyword is required only when transferring text files from a distributed to a z/OS environment and vice versa. If you specify this parameter, the REMOTECODEPAGE parameter is required.

**LOCALFILE(*file name*)**

Required. The name of the local file that you want to transfer. When uploading, this is the source file, when downloading, this is the target file.

**LOCALPWD(YES|NO)**

Specifies that the user name set for LOCALUSR is associated with a password. Typically, the password is required for users who schedule jobs to run on Windows workstations. LOCALPWD must be set to YES also if TRANSFERTYPE is set to UPLOAD and the file transfer is towards a z/OS server.

By setting LOCALPWD to YES, IBM® Z Workload Scheduler searches for the user password in the USRPSW parameter of the USRREC statement (for details, see [USRREC on page 45](#)).

**LOCALUSR(*local user name*)**

Specifies the local user, if the scheduled jobs run on Windows workstations. The value specified for LOCALUSR overrides the value specified for USRNAM in the USRREC statement. If you set LOCALUSR, the LOCALPWD parameter must also be set to YES.

Use the following syntax:

**To define a Windows domain user**

```
LOCALUSR(domainName\userName)
```

**To define a Windows user in the `username@web_domain` format**

```
LOCALUSR('userName@web_domain')
```

**MAXPORT(*max\_port*)**

The maximum port value to use on the client side of TCP data connections. For example, if you specify MAXPORT=8009, IBM Z Workload Scheduler restricts the port number to be lesser than or equal to the port 8009. The default value is 1035.

**MINPORT(*min\_port*)**

The minimum port value to use on the client side of TCP data connections. For example, if you specify MINPORT=8000, IBM Z Workload Scheduler restricts the port number to be greater than or equal to the port 8000.

**PASSIVEMODE(YES|NO)**

Specifies whether the server is passive or active in establishing connections for data transfers. If you set this option to NO, the server establishes the data connection with the client (active mode), if you set this option to YES, the client establishes the data connection with the server (passive mode). The default value is NO.

**PROTOCOL(FTP|FTPS|FTPES|WINDOWS|SSH)**

The protocol to be used for the file transfer. Allowed values are:

**FTP**

A standard network protocol used to exchange files over a TCP/IP-based network, such as the Internet.

**FTPS**

An extension to the File Transfer Protocol (FTP) that adds support for the Transport Layer Security (TLS) and the Secure Sockets Layer (SSL) cryptographic protocols. Specifically, the supported protocol is TLS security for FTP sessions with **implicit** secure TLS login and with private security level for the data connection.

**FTPES**

An extension to the File Transfer Protocol (FTP). Specifically, the supported protocol is TLS security for FTP sessions with **explicit** TLS security and private security level for the data connection.

**WINDOWS**

The Microsoft™ file sharing protocol. Specify the root shared directory in the REMOTEFIELD keyword. Specify the address of the workstation hosting the shared directory in the SERVER keyword.

**SSH**

A network protocol that provides file access, file transfer, and file management functions over any data stream.

**REMOTECODEPAGE(*file name*)**

The name of the code page used on the remote system. This keyword is required only when transferring text files from a distributed to a z/OS environment and vice versa. If you specify this parameter, the LOCALCODEPAGE parameter is required. If you want to use a custom code page, define the REMOTECODEPAGE parameter as follows:

```
REMOTECODEPAGE (USER: custom_code_page)
```

where *custom\_codepage* is the code page defined by the user.

For example, to use the tcpip.ftpd.ftpxlbin.france3 custom code page, define the REMOTECODEPAGE parameter as follows:

```
REMOTECODEPAGE (USER:tcpip.ftpd.ftpxlbin.france3)
```



**REMOTEFILE(*file name*)**

The name of the remote file that you want to transfer. When uploading, this is the target file, when downloading, this is the source file. This keyword is required.

**SERVER(*host name*)**

The host name of the server where the file transfer is to be performed or where the database is located. This keyword is required if you set JOBTYP to `(/file transfer)` or `(/database)`.

**TIMEOUT(*seconds*)**

Specifies the number of seconds to be used for the file transfer operation. The default value is 60 seconds.

**TRANSFERMODE(TEXT|BINARY)**

The mode of file transfer that you want to perform, either text or binary.

**TRANSFERTYPE(UPLOAD|DOWNLOAD)**

The type of file transfer that you want to perform; either upload or download. This keyword is required.

**Example****Examples**

The following is an example of a JOBTYP statement to transfer a file using the FTP protocol:

```
//JOBTYP
JOBTYP(/file transfer)
TRANSFERTYPE(DOWNLOAD)
SERVER(server address)
LOCALFILE(C:\file1.txt)
REMOTEFILE(/file1.txt)
PROTOCOL(FTP)
JOBUSR(username)
JOBPWD(YES)
//END JOBTYP
```

The following is an example of a JOBTYP statement to transfer a file using the SSH protocol:

```
//JOBTYP
JOBTYP(/file transfer)
TRANSFERTYPE(DOWNLOAD)
SERVER(server address)
LOCALFILE(C:\file1.txt)
REMOTEFILE(/home/provaftp/file1.txt)
PROTOCOL(SSH)
JOBUSR(username)
JOBPWD(YES)
//END JOBTYP
```

The following is an example of a JOBTYP statement to transfer a file using the WINDOWS protocol:

```
//JOBTYP
JOBTYP(/file transfer)
TRANSFERTYPE(UPLOAD)
SERVER(server address)
LOCALFILE(C:\file3.txt)
```

```
REMOTEFILE(shared directory\file88.txt)
PROTOCOL(WINDOWS)
JOBUSR(username)
JOBPWD(YES)
//END JOBREC
```

The following example shows a JOBREC statement to transfer a native z/OS file from a z/OS workstation to a Windows workstation:

```
//JOBREC
JOBTYPE(/file transfer)
TRANSFERTYPE(DOWNLOAD)
TRANSFERMODE(TEXT)
SERVER(9.168.101.41)
LOCALFILE(d:\MyFTPRemoteTextFile.txt)
REMOTEFILE('TWSZ.REMOTE.TEXTFILE')
LOCALCODEPAGE(ISO8859-1)
REMOTECODEPAGE(IBM-037)
JOBUSR(root)
JOBPWD(YES)
PROTOCOL(FTP)
//END JOBREC
```

The following example shows a passive mode transfer with a timeout of 10 seconds. The system determines which port to use between 1034 and 1035:

```
//JOBREC
JOBTYPE(/file transfer)
TRANSFERTYPE(DOWNLOAD)
TRANSFERMODE(TEXT)
SERVER(9.168.107.126)
LOCALFILE(d:\MyFTPRemoteTextFile11.txt)
REMOTEFILE('TWS851.REMOTE.TEXTFILE')
LOCALCODEPAGE(ISO8859-1)
REMOTECODEPAGE(IBM-037)
TIMEOUT(10)
MINPORT(1034)
MAXPORT(1035)
PASSIVEMODE(YES)
JOBUSR(LNDN_USER)
JOBPWD(YES)
PROTOCOL(FTPES)
//END JOBREC
```

## Syntax diagram for web service job types

### Purpose

If you set JOBTYPE to `(/web service)`, you can run an existing web service:

This section provides detailed information about the syntax diagram for the web service job type.

## Format

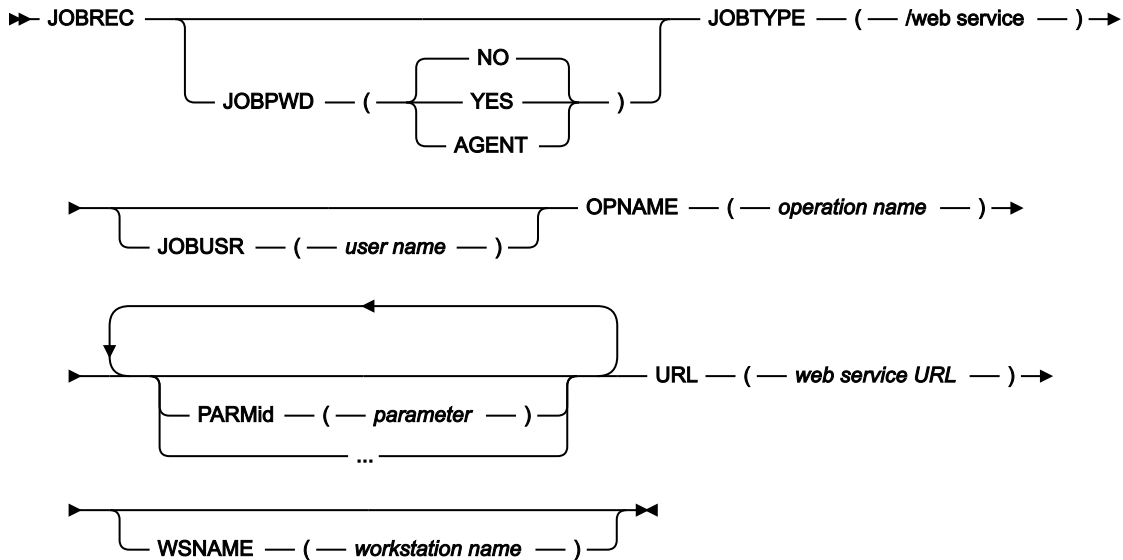

## Parameters

### JOBPWD(YES|NO|AGENT)

Specifies if the user name entered in **JOBUSR** or set by using the job-submit exit **EQQUX001** is associated with a password.

If you set **JOBPWD** to **YES**, IBM Z Workload Scheduler searches for the user password in the **USRPSW** keyword of the **USRREC** statement (for details, see *IBM Z Workload Scheduler: Customization and Tuning*).

If you set **JOBPWD** to **AGENT**, this means that the password is resolved locally on the agent. The password must have been defined on the agent by means of the [param on page 48](#) command. This feature is available independently of the operating system of the workstation.

Typically, the password is required for users who schedule jobs to run on Windows™ workstations. Set **JOBPWD** to **NO** if the user works with UNIX™ workstations and if no password is required.

### JOBTYP(/xajob/access method name|j2ee/jms|web service|file transfer|database|java)

To run a web service job, specify **/web service**. For information about the other types of job, see the specific section for each job type. This keyword is required.

#### **/web service**

Set this value to submit a web service job.

### JOBUSR(*user name*)

The user name for accessing the web service, if required.

If the user schedules jobs to run on Windows™ workstations, ensure that a user password is also defined (see the **JOBPWD** keyword).

- If you are defining a Windows™ domain user, use the following format:

```
JOBUSR(domainName\user1)
```

- If you are defining a Windows™ user in the *username*@*internet\_domain* format, use the following format:

```
JOBUSR('administrator@mywindow.com')
```

To specify the user name, you can also use the job-submit exit EQQUX001. This user name overrides the value specified for JOBUSR. In turn, the value specified for JOBUSR overrides the value specified for USRNAM in the USRREC statement.

### **OPNAME(*operation name*)**

The name of the operation to run. This keyword is required.

### **PARM*id*(*parameter*)**

The parameter to be used when running the script or command. You can specify a series of PARM*id* keywords, where *id* is a unique numeric value, including null and zero.

### **URL(*web service URL*)**

The URL of the web service to be called. This keyword is required.

### **WSNAME(*workstation\_name*)**

The name of the workstation from which user name and password must be retrieved. User name and password can be specified in the statement, using the JOBUSR and JOBPWD keywords, or can be associated to a workstation with the USRREC statement. With the WSNAME keyword, you can specify a workstation where the user name and password are stored, which is different from the workstation where the job runs.

## **Example**

## **Examples**

The following is an example of a JOBREC statement to call a web service that calculates the sum of the specified parameters:

```
//JOBREC
JOBTYPE(/web service)
PARM1(10)
PARM2(20)
JOBUSR(administrator)
JOBPWD(YES)
OPNAME(getSum)
URL(http://manchester.testlab.uk.service.com:9467/Sum/services/Sum/wsdL/Sum.wsdL)
//END JOBREC
```

## Syntax diagram for Java job type

### **Purpose**

If you set JOBTYPE to (/java), you can run an existing Java class:

This section provides detailed information about the syntax diagram for the Java job type. The following syntax rules apply:

- Use the UNIX format for the value of the JARPATH keyword.

## Format

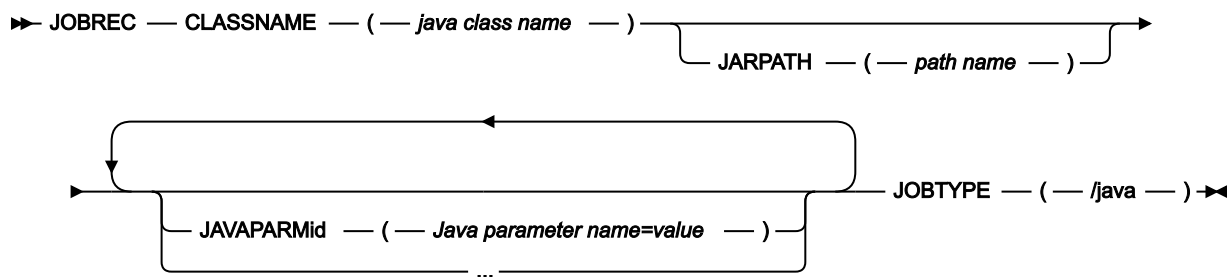

## Parameters

### **CLASSNAME**(*java class name*)

The name of the Java class to run. This keyword is required.

### **JARPATH**(*path name*)

The path to the jar file.

### **JAVAPARMid**(*Java parameter name=value*)

The Java parameter used by the Java class. You can define multiple parameters in the same job by specifying a series of **JAVAPARMid** keywords, where *id* is a unique numeric value, including null and zero. For example, you can define **JAVAPARM1**, **JAVAPARM2**, and so on.

Use the following format, which is case sensitive:

```
JAVAPARMid(Java parameter name=value)
```

Where:

#### **Java parameter name**

The name of the Java parameter.

#### **value**

The value associated with the Java parameter.

### **JOBTYP**(/*xajob/access method name/j2ee/jms/web service/file transfer/database/java*)

To run a Java job, specify **/java**. For information about the other types of job, see the specific section for each job type.

#### **/java**

Set this value to submit a Java job. Ensure that you have list permissions for the folder specified in the `jarPath` property.

## Example

## Examples

The following is an example of a JOBREC statement to run a class with name mypackage.base:

```
//JOBREC
JOBTYPE(/java)
CLASSNAME(mypackage.base)
JAVAPARM1(name=backup)
JARPATH(c:/jarPath2)
//END JOBREC
```

## Syntax diagram for xajob job type

### Purpose

If you set JOBTYPE to `/xajob/access method name`, you can run a job on an extended agent:

This section provides detailed information about the syntax diagram for the xajob job type.

### Format

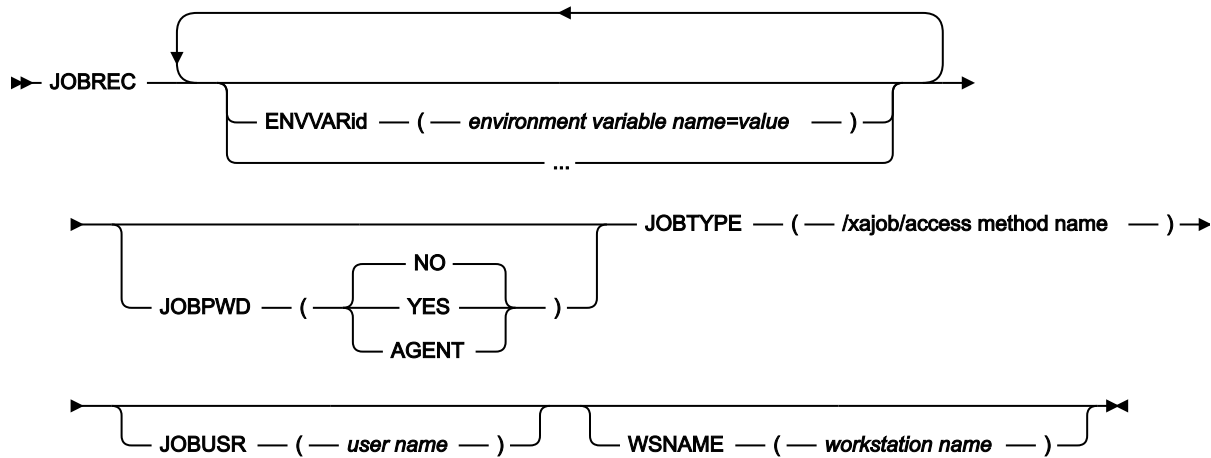

### Parameters

#### ENVVARid(environment variable name=value)

The environment variable that the task launcher must set before submitting the job. You can specify a series of ENVVARid keywords, where *id* is a unique numeric value, including null and zero.

Use the following format, which is case sensitive:

```
ENVVARid( environment variable name=value)
```

Where:

#### **environment variable name**

The name of the environment variable.

**value**

The value associated with the environment variable.

**JOBPWD(YES|NO|AGENT)**

Specifies if the user name entered in JOBUSR or set by using the job-submit exit EQQUX001 is associated with a password.

If you set JOBPWD to `YES`, IBM Z Workload Scheduler searches for the user password in the USRPSW keyword of the USRREC statement (for details, see *IBM Z Workload Scheduler: Customization and Tuning*).

If you set JOBPWD to `AGENT`, this means that the password is resolved locally on the agent. The password must have been defined on the agent by means of the [param on page 48](#) command. This feature is available independently of the operating system of the workstation.

Typically, the password is required for users who schedule jobs to run on Windows™ workstations. Set JOBPWD to `NO` if the user works with UNIX™ workstations and if no password is required.

**JOBTYP(*/xajob/access method name*|/j2ee/jms|web service|file transfer|database|java)**

To run an xajob, specify */xajob/access method name*. For information about the other types of job, see the specific section for each job type. This keyword is required.

***/xajob/access method name***

The name of the access method hosted by the extended agent on which you want to submit the job. For example, for a job to be submitted on a SAP extended agent, this value might be `/xajob/r3batch`. If you set this keyword, the JOBCMD keyword value is ignored.

**JOBUSR(*user name*)**

The name of the user submitting the job.

If the user schedules jobs to run on Windows™ workstations, ensure that a user password is also defined (see the JOBPWD keyword).

- If you are defining a Windows™ domain user, use the following format:

```
JOBUSR(domainName\user1)
```

- If you are defining a Windows™ user in the *username@internet\_domain* format, use the following format:

```
JOBUSR('administrator@mywindow.com')
```

To specify the user name, you can also use the job-submit exit EQQUX001. This user name overrides the value specified for JOBUSR. In turn, the value specified for JOBUSR overrides the value specified for USRNAM in the USRREC statement.

**WSNAME(*workstation\_name*)**

The name of the workstation from which user name and password must be retrieved. User name and password can be specified in the statement, using the JOBUSR and JOBPWD keywords, or can be associated to a

workstation with the USRREC statement. With the WSNAME keyword, you can specify a workstation where the user name and password are stored, which is different from the workstation where the job runs.

**Example**

**Examples**

The following is an example of a JOBREC statement to un a job using the r3batch access method. The content of the JOBTYP keyword is case sensitive:

```
//JOBREC
JOBTYP(/xajob/r3batch)
ENVVAR10(VAL=10)
//END JOBREC
-JOB SAPJOB -USER SAPUSER
```

**Syntax diagram for J2EE jms job type**

**Purpose**

If you set JOBTYP to (/j2ee/jms), you can run an existing j2ee jms class:

This section provides detailed information about the syntax diagram for the j2ee jms job type.

**Format**

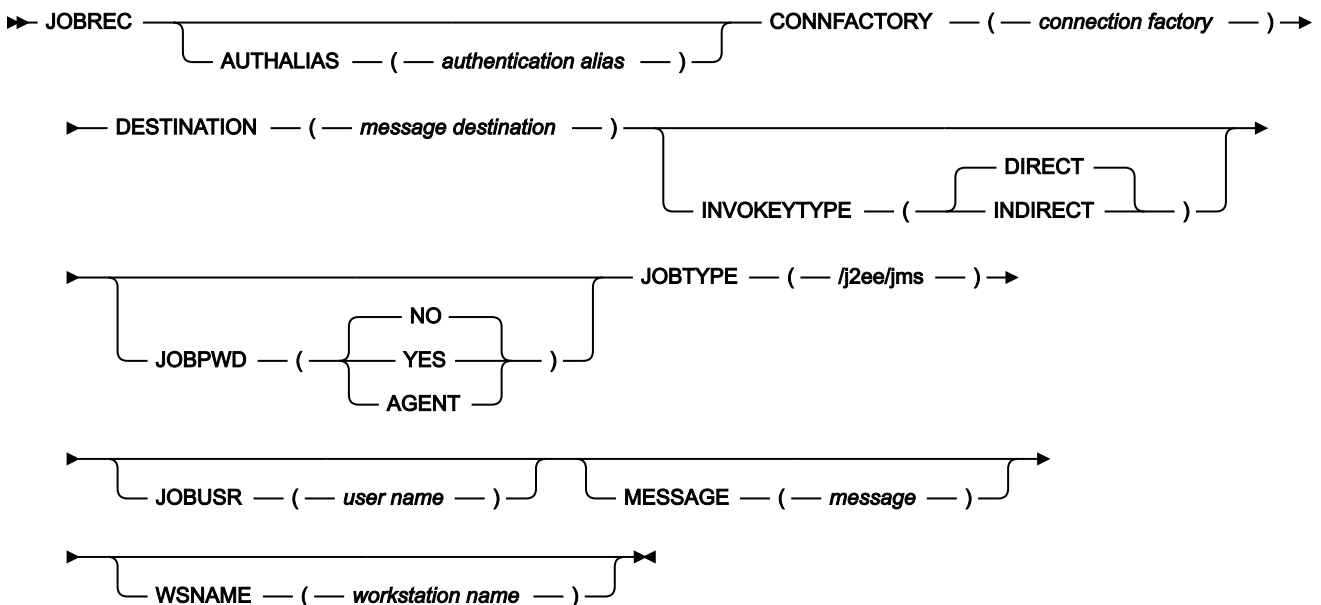

**Parameters**

**AUTHALIAS(authentication alias)**

The Java™ Authentication and Authorization Service (JAAS) authentication alias. This keyword is valid only if you set INVOKEYTYPE to (DIRECT).



**CONNFACTORY**(*connection factory*)

The administered object that a client uses to create a connection to the Java™ Messaging Service (JMS) provider. This keyword is required.

**DESTINATION**(*message destination*)

The administered object that encapsulates the identity of a message destination, which is where messages are delivered and consumed. This keyword is required.

**INVOKEYTYPE**(**INDIRECT**|**DIRECT**)

The type of scheduling. This keyword is valid only if you set JOBTYP to `( /j2ee/jms )`. Allowed values are:

**INDIRECT**

IBM Z Workload Scheduler uses an existing WebSphere® Application Server scheduling infrastructure already configured on an external WebSphere® Application Server.

**DIRECT**

IBM Z Workload Scheduler immediately forwards the job to the components of the external WebSphere® Application Server instance.

**JOBPWD**(**YES**|**NO**|**AGENT**)

Specifies if the user name entered in JOBUSR or set by using the job-submit exit EQQUX001 is associated with a password.

If you set JOBPWD to **YES**, IBM Z Workload Scheduler searches for the user password in the USRPSW keyword of the USRREC initialization statement (for details about this statement, see *Customization and Tuning*).

If you set JOBPWD to **AGENT**, this means that the password is resolved locally on the agent. The password must have been defined on the agent by issuing the [param on page 48](#) command. This feature is available independently of the operating system of the workstation.

Typically, the password is required for users who schedule jobs to run on Windows™ workstations. Set JOBPWD to **NO** if the user works with UNIX™ workstations and if no password is required.

**JOBTYP**(**/xajob/access method name/j2ee/jms/web service/file transfer/database/java**)

To run a j2ee jms job, specify **/j2ee/jms**. For information about the other types of job, see the specific section for each job type. This keyword is required.

**/j2ee/jms**

Set this value to submit a Java™ Messaging Service (JMS) job.

**JOBUSR**(*user name*)

The user name for accessing WebSphere® Application Server, if required.

If the user schedules jobs to run on Windows™ workstations, ensure that a user password is also defined (see the JOBPWD keyword).

- If you are defining a Windows™ domain user, use the following format:

```
JOBUSR(domainName\user1)
```

- If you are defining a Windows™ user in the *username*@*internet\_domain* format, use the following format:

```
JOBUSR('administrator@mywindom.com')
```

To specify the user name, you can also use the job-submit exit EQQUX001. This user name overrides the value specified for JOBUSR. In turn, the value specified for JOBUSR overrides the value specified for USRNAM in the USRREC statement.

### MESSAGE(*message*)

The object that is sent from one application to another.

### WSNAME(*workstation\_name*)

The name of the workstation from which user name and password must be retrieved. User name and password can be specified in the statement, using the JOBUSR and JOBPWD keywords, or can be associated to a workstation with the USRREC statement. With the WSNAME keyword, you can specify a workstation where the user name and password are stored, which is different from the workstation where the job runs.

### Example

### Examples

The following is an example of a JOBREC statement to submit a JMS job:

```
//JOBREC
JOBTYPE(/j2ee/jms)
INVOKEYTYPE(DIRECT)
CONNFACTORY(jms/MyCF)
DESTINATION(jms/MyQueue)
MESSAGE(This is my message)
JOBUSR(administrator)
JOBPWD(YES)
//END JOBREC
```

## Syntax diagram for native job type

This section describes the native job type.

## Syntax diagram for script and executable job type

### Purpose

If you set JOBCMD to `(script)` or `(executable)`, you can choose between the following native job types:

- Script
- Executable

This section provides detailed information about the syntax diagram for the script and executable job types. The following syntax rules apply:

- The JOBCMD keyword is required for executable and optional for script job types.

## Format

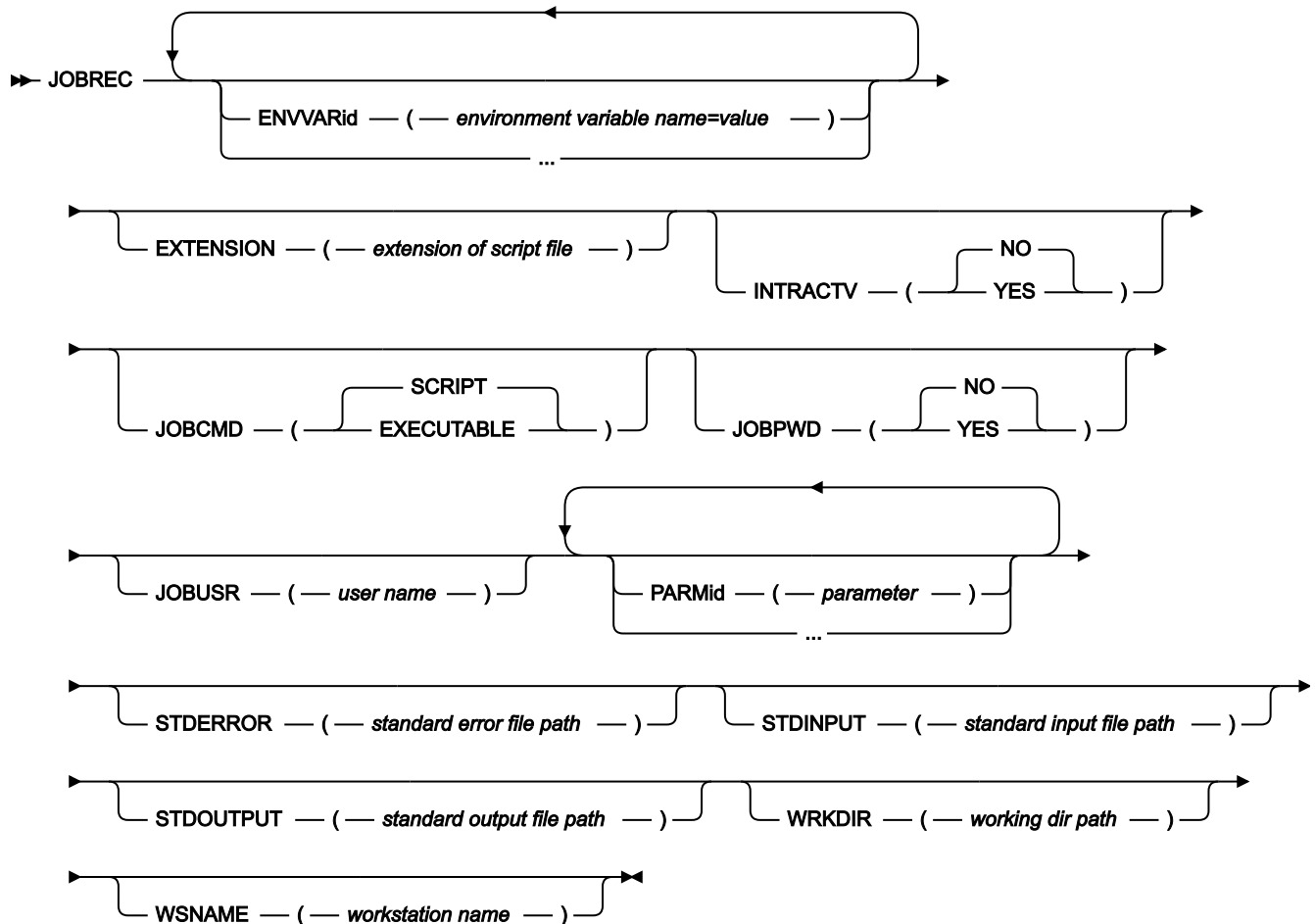

## Parameters

### ENVVARid(*environment variable name=value*)

The environment variable that the task launcher must set before submitting the job. You can specify a series of ENVVARid keywords, where *id* is a unique numeric value, including null and zero.

Use the following format, which is case sensitive:

```
ENVVARid(environment variable name=value)
```

Where:

#### ***environment variable name***

The name of the environment variable.

**value**

The value associated with the environment variable.

**EXTENSION(*extension of script file*)**

The extension (bat, vbs, etc.) of the script file launched by the job. This keyword is valid only when JOBCMD is set to SCRIPT.

**INTRACTV(YES|NO)**

Specifies if a Windows™ job runs interactively on the Windows™ desktop. This keyword is valid only for jobs running on Windows™ IBM Z Workload Scheduler Agent workstations.

**JOBCMD(EXECUTABLE|SCRIPT)**

The content of the job definition member. Valid values are:

**SCRIPT**

The job definition member contains the command or script to be run. You can add the EXTENSION keyword to specify the file extension.

**EXECUTABLE**

The job definition member invokes the job that is to be run, which is stored locally on the IBM Z Workload Scheduler Agent workstation. If you did not set any value for the WRKDIR keyword, you must specify the fully qualified path to the job.

**JOBPWD(YES|NO)**

Specifies that the user name set in JOBUSR or by using the job-submit exit EQQUX001 is associated with a password. If you set JOBPWD to YES, IBM Z Workload Scheduler searches for the user password in the USRPSW keyword of the USRREC statement (for details, see *IBM Z Workload Scheduler: Customization and Tuning*).

Typically, the password is required for users who schedule jobs to run on Windows™ workstations. Set JOBPWD to NO if the user works with UNIX™ workstations.

**JOBUSR(*user name*)**

The user name for running the script or executable, if required.

If the user schedules jobs to run on Windows™ workstations, ensure that a user password is also defined (see the JOBPWD keyword).

- If you are defining a Windows™ domain user, use the following format:

```
JOBUSR(domainName\user1)
```

- If you are defining a Windows™ user in the *username@internet\_domain* format, use the following format:

```
JOBUSR('administrator@mywindow.com')
```

To specify the user name, you can also use the job-submit exit EQQUX001. This user name overrides the value specified for JOBUSR. In turn, the value specified for JOBUSR overrides the value specified for USRRAM in the USRREC statement.

#### **PARMid(*parameter*)**

The parameter to be used when running the script or command. You can specify a series of PARM*id* keywords, where *id* is a unique numeric value, including null and zero.

#### **STDERROR(*standard error file path*)**

The fully qualified name of the file where the standard error must be redirected.

#### **STDINPUT(*standard input file path*)**

The fully qualified name of the file to be used as standard input.

#### **STDOUTPUT(*standard output file path*)**

The fully qualified name of the file to be used as standard output.

#### **WRKDIR(*working dir path*)**

The fully qualified path to the directory where the script or command is to be run.

#### **WSNAME(*workstation\_name*)**

The name of the workstation from which user name and password must be retrieved. User name and password can be specified in the statement, using the JOBUSR and JOBPWD keywords, or can be associated to a workstation with the USRREC statement. With the WSNAME keyword, you can specify a workstation where the user name and password are stored, which is different from the workstation where the job runs.

### **Example**

### **Examples**

The following is an example of a JOBREC statement to invoke the script ALLOCATE.BAT stored locally on the IBM Z Workload Scheduler Agent workstation:

```
//JOBREC
WRKDIR(C:\)
STDERROR(D:\MYDIR\ERROR.TXT)
STDINPUT(D:\MYDIR\INPUT.TXT)
STDOUTPUT(D:\MYDIR\OUTPUT.TXT)
STDOUTPUT(D:\MYDIR\NEW.TXT)
JOBCMD(EXECUTABLE)
PARM(300)
PARM2(ELEMENT)
//END JOBREC
D:\MYDIR\ALLOCATE.BAT
```

The following is an example of a JOBREC statement to run the command DIR on the directory C:\PROGRAM on the IBM Z Workload Scheduler Agent workstation:

```
//JOBREC
WRKDIR(C:\PROGRAM)
JOBCMD(SCRIPT)
```

```
EXTENSION(vbs)
//END JOBREC
DIR
```

## Using variable substitution

The variable substitution mechanism that is used in IBM Z Workload Scheduler native job types works the same way when scheduling jobs on IBM Z Workload Scheduler Agents. The variable substitution mechanism changes when you define job types with advanced options, such as Java™ jobs that run a Java™ class, or file transfer jobs that transfer files to and from a server, to name a few. These types of jobs are created and edited using the Dynamic Workload Console.

When you define a variable for job types with advanced options, including those defined in a JOBREC using the JOBTYP keyword, the variable must be preceded by the \$ (dollar) sign and enclosed in {} (curly brackets), as follows:

```
${variable_name}
```

If you want to nest variables, use the following syntax:

```
${variable_1_name ${variable_2_name}}
```

In this case, variable\_2 is resolved first and provides the value for variable\_1.

With job types with advanced options you also have the option to define and use variables locally on the IBM Z Workload Scheduler Agents. To define a variable on the agent, use the [param on page 48](#) command. After defining the variable, to add it within a job definition so that it is resolved locally on the agent at run time, use the following syntax:

```
${Agent:variable_name}
```

User passwords can be similarly parameterized for local resolution. For details, see [Defining variables and passwords for local resolution on page 48](#).

Dependent variables and promptable variables are not supported in job types with advanced options.

For more information, see the section about variable substitution in *Managing the Workload*.

## Defining file dependencies to check for file changes

You can use the **filewatch** utility to check for file system changes on files and directories, for example, when you want to make sure that a file exists before running a job that processes that file. By defining a job that runs the **filewatch** utility, you can implement file dependency, that is, a relationship between a file and an operation in which specific activity on the file determines the starting of the operation.



**Note:** The filewatch utility is not available for Limited Fault-Tolerant Agent for IBM i systems. For these systems, see the *Limited Fault-Tolerant Agent IBM i* manual.

To run the **filewatch** utility you can use variable substitution, which occurs when:

- The controller submits the job associated to a JOBLIB member. For details about the scheduler job tailoring, see *IBM Z Workload Scheduler: Managing the Workload*.
- The IBM Z Workload Scheduler Agent submits the job. For details about submitting a job, see [Defining a job in the JOBLIB data set on page 73](#).

## Syntax

**filewatch -v | -u | -?**

**filewatch -c[ondition] condval -f[ilename] file\_path -dea[dline] deadline**

**[-i[nterval] interval]**

**[-dat[abase] log\_extension]**

**[-r[eturncode] rc]**

**[-t[race] trace level]**

The arguments are not positional. You can use an abbreviated format for all the arguments. Generally you can truncate the arguments to any position following the first character, except for `deadline` and `database` that require at least three characters.

**-v**

Returns the command version and exits.

**-u**

Returns command usage information and exits.

**-?**

Same as **-u**

**-condition**

The condition to be checked. Valid values are:

**wcr | waitCreated**

Waits until the file exists. If the file already exists, **filewatch** exits immediately. If `-filename` argument specifies a directory, the process waits until the directory exists and contains a new file.

**wmr | waitModificationRunning**

Waits until the file size or modification time changes. If `-filename` argument specifies a directory, the process waits until the size or earlier file modification time changes, when a file is created, modified, or deleted.

**wmc | waitModificationCompleted**

Checks that the file size or modification time stopped changing, meaning that **filewatch** waits for three search intervals without any change. If `-filename` argument specifies a directory, the process checks the size or the earlier file modification time change, for example if the number of directory files and the earlier file modification time does not change within three search intervals.

### **wmrc | waitModificationRunningCompleted**

Waits until the file size or modification time changes and stops changing, meaning that, after the first change, **filewatch** waits for three search intervals without any further change. If `-filename` argument specifies a directory, the process checks the size or the earlier file modification time change, for example if the number of directory files and the earlier file modification time does not change within three search intervals.

### **wdl | waitDelete**

Stops running when the file is deleted. If `-filename` argument specifies a directory, the process waits until a file is deleted from the directory.

### **-filename**

The file path to be processed. You can embed blank or special characters, by using double quotation marks. Wildcard characters are not supported. To include more files in the monitoring process, you can store those files in a specific directory and use a file path specifying that directory. When **filewatch** is used on a Windows™ server, and the file path specifies a directory, the path name must not include a trailing forward slash "/" character.

### **-deadline**

The deadline period, expressed in seconds. The allowed formats are:

- An integer in the range 0 to 31536000 (the upper value corresponds to one year). To have **filewatch** performing an indefinite loop, specify 0.
- *hh:mm:ss*, in the range 00:00:01 to 24:00:00, to select a time within the same day when **filewatch** started.

### **-interval**

The file search interval, expressed in seconds. Specify an integer in the range:

- 5–3600 when specifying **wcr** or **wdl** as condition value.
- 30–3600 otherwise.

The default is 60.

### **-database**

Optional extension of the log database, that is the database where **filewatch** stores the file status. If you specify this value, **filewatch** updates the `TWA_home/TWS/filewatchdb.log_extension` database, otherwise `TWA_home/TWS/filewatchdb` is updated.

For details about the log database, see [Maintaining the filewatch log database on page 105](#).

### **-returncode**

The exit return code, if the condition is not successfully checked by the deadline. Specify an integer in the range 0 to 256. The returncode value is ignored if you specify 0 as deadline value. The default is 4.



**-trace**

Trace level for internal logging and traces. Possible values are:

**0**

To receive error messages only.

**1**

Indicates the *fine* level, to receive the most important messages with the lowest volume.

**2**

Indicates the *finer* level, to activate entry and exit traces.

**3**

Indicates the *finest* level, to receive the most detailed tracing output.

The default value is 0.

You find the trace output in the log of the job that run **filewatch**.

## Maintaining the filewatch log database

The log database is used to store **filewatch** activity data. This log is located in the `TWA_home/TWS` directory. The default name is `filewatchdb`.

When processing a file, **filewatch** uses it to store records with information about:

- File name.
- File status. The allowed values are Exist, Created, Running, Completed, RunningCompleted, or Deleted.
- Date and time of file creation at the entry update time.
- Date and time of the last file modification at the entry update time.
- Date and time of the last entry update.



**Note:** The log contains only one entry for each file.

To maintain the log database, use the **filewatchdb** utility.

### Syntax

```
filewatchdb -v | -u | -?
```

```
filewatchdb -c[ondition] condval
```

```
[-f[ilename] file_path
```

```
[-dat[abase] log_extension]
```

The arguments are not positional.

## Arguments

**-v**

Returns the command version and exits.

**-u**

Returns command usage information and exits.

**-?**

Same as **-u**

**-condition**

The condition to be checked. Valid values are:

**bid| build**

Rebuild the log database.

**dlt | delete**

Delete the log database record corresponding to the filename argument value.

**gls | getLastStatusChange**

Gets and returns the log database record corresponding to the filename argument value.

**-filename**

Use this argument to delete the entry corresponding to the specified value. You can embed blank or special characters, by using double quotation marks. Use \* as wildcard character. This argument is required if you specify dlt (delete) or gls (getLastStatusChange) as condition value.

**-database**

Optional extension of the log database to be accessed. If you specify this value, **filewatchdb** accesses the `TWA_home/TWS/filewatchdb.log_extension` database, otherwise `TWA_home/TWS/filewatchdb` is accessed.

## Checking for file changes with filemonitor

You can use the **filemonitor** utility to monitor for file changes (files that were either created or modified) within a time interval. This could be useful when, for example, you want to make sure that a file exists before running a job that processes that file. By defining a job that runs the **filemonitor** utility, you can implement file dependency, that is, a relationship between a file and an operation in which specific activity on the file determines the starting of the operation.



### Note:

1. The **filemonitor** utility is available on the z-centric agents with IBM Workload Scheduler V9.4, Fix Pack 1 installed.
2. To issue **filemonitor** from the command line, ensure that you set up the environment with the following command from `<TWA_home>`:



## Windows

```
twa_env.cmd
```

## UNIX and Linux

```
../twa_env.sh
```

- To issue **filemonitor** from a job, use the command `filemonitorlauncher`. The same arguments valid for **filemonitor** apply to `filemonitorlauncher`.

## Syntax

**filemonitor -V | -U**

```
filemonitor {-path path_to_monitor | -epath path_to_monitor}
[-exitOnPathToMonitorNotFound]
-event {fileCreated | fileModified} [-modificationCompletedTime seconds]
[-repositoryName repository_name]
[-repositoryPath repository_path]
[-recursive]
[-outputFile output_filename]
[-scanInterval scan_interval]
[-maxEventsThreshold max_events]
[-minFileSize min_file_size]
[-timeout seconds | time_of_the_day]
[-preserveEventsOnDelete seconds]
```

**filemonitor -reset**

```
[-repositoryName repository_name]
[-repositoryPath repository_path - generateEventsOnFirstScan]
```

## Arguments



**Note:** If you set the same argument more than once, the last value specified is applied and no error message is reported.

**-V**

Displays the command version and exits.

**-U**

Displays command usage information and exits.

**-path *path\_to\_monitor***

The path where the files to be processed are located. To include more files in the monitoring process, store all the files in the directory set with the **-path** argument.

The following syntax rules apply:

- Paths containing blank or special characters must be specified within double quotation marks.
- Wildcard characters question mark (?) and asterisk (\*) are supported.

Universal Naming Convention (UNC) paths are also supported with the following syntax types:

- `\\server_name\share_name\directory_name\...`
- `\\?\UNC\server_name\share_name\directory_name`
- `\\?\path_name`

**-epath *path\_to\_monitor***

The path where the files to be processed are located, always specified with slashes (/) as separators. Backslashes (\) are not allowed as separators, even if you are indicating a Windows path. To include more files in the monitoring process, store all the files in the directory set with the **-epath** argument.

The following syntax rules apply:

- Paths containing blank or special characters must be specified within double quotation marks.
- Wildcard characters question mark (?) and asterisk (\*) are supported.
- Any character other than backslash (\), question mark (?), asterisk (\*), square brackets ([ ]) or a backslash at the end of the value (\) is intended exactly as it is written. For example, `MYpath` is not equivalent to `mypath`.
- Use the syntax `[class description]` to indicate a single character as follows:

**[range\_of\_characters]**

A range of characters separated by a minus sign (-). For example, `A-B` or `1-9`.

**[list\_of\_characters]**

A string of characters. For example, `ABC` or `laX`.

- The characters exclamation mark (!) and caret (^) are used to reverse the sense. For example, `[!A-Z]` matches a single character that is not equivalent to any letter from A to Z. `[!F]` matches any character that is not F.

For example:

- `-epath /mypath/myp?th/e[!1].txt`
- `-epath /mypath/my[1-9]path/e[A-Z].txt`
- `-epath c:/mypath/p?th/e[!1].txt`

**[-exitOnPathToMonitorNotFound]**

Optionally, specify this argument to have the command exit if the specified path is not found.

**-event {fileCreated | fileModified} [-modificationCompletedTime seconds]**

The event type to be monitored. This argument is required when you specify **-path**.

Supported types are **fileCreated** and **fileModified**. For both types, you can set the

**-modificationCompletedTime**, which is the time interval, in seconds, that is used to determine when the event is sent.

**-event fileCreated**

As soon as the file is created, the event, `FileCreated`, is sent.

**-event fileModified**

As soon as the file is modified, the event, `ModificationCompleted`, is sent.

**-event fileCreated -modificationCompletedTime seconds**

When a file is created, the event is not sent immediately, but only after the interval of time specified by **-modificationCompletedTime***seconds* has elapsed, and during which no subsequent changes were made to the file, which includes the file being deleted and recreated with the same name.

**-event fileModified -modificationCompletedTime seconds**

When a file is modified, the event is not sent immediately, but only after the interval of time specified by **-modificationCompletedTime***seconds* has elapsed, and during which no subsequent changes were made to the file.

**-repositoryName repository\_name**

Optionally, specify a database where to log the status of the retrieved files. The default is `filemonitor.db`.

**-repositoryPath repository\_path**

The path to the **filemonitor** database. The default is:

**Windows**

```
<TWA_home>\TWS\stdlist\JM\filemonitor
```

**UNIX and Linux**

```
<TWA_DATA_DIR>/TWS/stdlist/JM/filemonitor
```

Paths containing spaces must be enclosed within double quotes. Wildcard characters are not allowed.

**-generateEventsOnFirstScan**

All the files retrieved during the first scan performed by **filemonitor** are considered as created or modified, and can generate events. This argument is available only if you specify the **repositoryPath** argument.

**-recursive**

Optional. The monitoring process includes subdirectories.

**-outputFile *output\_filename***

Optional. An output file where to store the retrieved events. Ensure that the directory where the output file is to be created is already existing. The command output is also printed to standard output and stored in the job properties, if you launch the **filemonitor** command from a job. Wildcard characters are not allowed.

**-scanInterval *scan\_interval***

Optional. A period of time in seconds between two consecutive checks on the files being created or modified. The default value is 300 seconds. The supported range is 1-3600 seconds.

**-maxEventsThreshold *max\_events***

Optional. The maximum number of events to be returned. The default value is **1**. If you specify **all**, all events are returned.

**-minFileSize *min\_file\_size***

Optional. The minimum size in bytes that files must reach to be included in the scan. The default value is **0**.

**-timeout *seconds* | *hh:mm:ss***

Optional. You can specify the maximum period, in seconds, that **filemonitor** runs or set the time of the current day until which **filemonitor** runs. The time refers to the local time of the workstation where **filemonitor** is running.

If you do not specify this parameter, **filemonitor** runs indefinitely.

**-preserveEventsOnDelete**

Optional. Returns events on the specified file, also if the file was deleted in the meantime. If you do not specify this argument, when a file is deleted all events preceding the file deletion, if any, are discarded.

**-reset**

Resets the information collected. With this argument you can optionally specify a **-repositoryName** and **-repositoryPath**.

## Configuring trace properties for filemonitor

To configure the trace properties for **filemonitor**, edit the [FileMonitor.Logging] section in the `FileMonitor.ini` file located in the following path, and restart the **filemonitor** utility.

### Windows

```
<TWA_Home>\TWS\ITA\cpa\config
```

### UNIX and Linux

```
<TWA_DATA_DIR>\TWS\ITA\cpa\config
```

The section containing the trace properties is named:

```
[FileMonitor.Logging.cclog]
```

**FileMonitor.trhd.fileName**

The name of the trace file.

**FileMonitor.trhd.maxFileBytes**

The maximum size that the trace file can reach. The default is 1024000 bytes.

**FileMonitor.trhd.maxFiles**

The maximum number of trace files that can be stored. The default is 3.

**FileMonitor.trfl.level**

Determines the type of trace messages that are logged. Change this value to trace more or fewer events, as appropriate, or on request from Software Support. Valid values are:

**DEBUG\_MAX**

Maximum tracing. Every trace message in the code is written to the trace logs.

**INFO**

All *informational*, *warning*, *error* and *critical* trace messages are written to the trace. The default value.

**WARNING**

All *warning*, *error* and *critical* trace messages are written to the trace.

**ERROR**

All *error* and *critical* trace messages are written to the trace.

**CRITICAL**

Only messages which cause the agent to stop are written to the trace.

The output trace (by default, `FileMonitor_trace.log`) is provided in XML format, and is located in `<TWA_Home>/TWS/stdlist/JM.`

**Return Codes**

**0**

The operation completed successfully.

**4**

**Filemonitor** stopped running, because timeout expired. No results were returned.

**8**

**Filemonitor** cannot run because the timeout is set to a time that is already passed.

**12**

**Filemonitor** stopped running, because the timeout expired without being able to access to the repository.

**-1**

An error occurred. Search the trace log (by default, `FileMonitor_trace.log`) for additional details.

## Comments

If one or more files were created or modified in between subsequent invocations, the modifications are detected. However, files already detected in a previous run are not listed again in subsequent invocations. Wildcard characters are supported in both file names and directory names.

## Example

In the following example, the **filemonitor** command checks every 2 minutes for all files created in the `C:\temp\logs` path and having a minimum size greater than 1024 bytes. The check is performed on all sub folders and the results are stored in `C:`

`\backup\logs\reports.txt`:

```
filemonitor -path "C:\temp\logs" -event fileCreated -recursive
-outputFile "C:\backup\logs\reports.txt"
-scanInterval 120 -maxEventsThreshold all -minFileSize 1024
```

## Promoting critical jobs

An overview of the mechanism that is behind the promotion of critical jobs, or of their predecessors, running on IBM Z Workload Scheduler Agents, including pools and dynamic pools.

The promotion of a critical job is the process whereby the execution of a job in the critical path, that is about to miss its deadline, is provided with more resources. Thus, it is redirected to a more powerful or faster dynamic agent, to idle workstations in a pool or dynamic pool, to an agent allocated to the execution of critical work.

As soon as IBM® Z Workload Scheduler determines that a job flagged as critical is not going to meet its deadline, it automatically updates the definition of the job, and of as many of its predecessors as necessary (that is, all the jobs in the critical path of the critical job), with the `tws.job.promoted` and `tws.job.resourcesForPromoted` promotion variables. These variables set the dynamic workload broker component to perform the load balancing required to guarantee that the job is run on time.

If the critical job is to be processed in a dynamic pool, the variables must be added manually to the job definition. For details, see the section about promoting jobs scheduled on dynamic pools in the *IBM Workload Scheduler: User's Guide and Reference*.

To control the priority allocation of system resources to the jobs in the critical network that must be promoted, you must configure the [PromotedNice on page 31](#) or [PromotedPriority on page 32](#) property of the `native job launcher` section in the `JobManager.ini` file of your IBM Z Workload Scheduler Agents.

When a [native on page 73](#) job is promoted, the `TWS_PROMOTED_JOB` environment variable is automatically added with value set to YES in the job definition. You can possibly take advantage of the value (YES or NO) of this variable in the script/program run by the native job, to implement a prioritization mechanism.

## Killing IBM Z Workload Scheduler Agent operations

The `kill` action ends an operation in the current plan that has already started. You can kill a running IBM Z Workload Scheduler Agent operation from any of the following interfaces:



- [ISPF on page 113](#)
- [PIF on page 113](#)
- [BCIT on page 113](#)
- [OCL on page 113](#)
- [Dynamic Workload Console on page 114](#)

This action can be taken only on `STARTED` operations that are in the `EXECUTING` status, so that their job ID is known.

The operation number (except for the OCL instructions, where the application number is the required parameter) is required to identify the operation that is to be killed.

## ISPF

### About this task

To kill an IBM Z Workload Scheduler Agent operation, perform the following steps:

1. Select option 3 (OPERATIONS) from the Modifying the Current® Plan panel (fast path 5.3).
2. Specify the list criteria for the operation you want to kill.

You see the Modifying Operations in the Current® Plan panel (EQQMOPRL). This panel lists the operations in the current plan that fulfill the list criteria you specified.

3. Enter the `κ` (Kill) row command next to the row that lists the operation.

The IBM Z Workload Scheduler Agent notifies the controller when the operation is killed.

## PIF

To kill an IBM Z Workload Scheduler Agent operation, use the following request:

```
MODIFY CPOP OPNO=operation_number OPCMD=KJ
```

For more detailed information, see *Developer's Guide: Driving IBM Z Workload Scheduler*.

## BCIT

To kill an IBM Z Workload Scheduler Agent operation, use the following instruction:

```
ACTION=MODIFY,RESOURCE=CPPOP,OPNO=operation_number,OPCMD=KJ
```

For more detailed information, see *Developer's Guide: Driving IBM Z Workload Scheduler*.

## OCL

To kill an IBM Z Workload Scheduler Agent operation, use the following instruction:

```
KILLJOB APPL(application_number) OPNO(operation_number)
```

For more detailed information, see *Developer's Guide: Driving IBM Z Workload Scheduler*.

## Dynamic Workload Console

### About this task

To kill an IBM Z Workload Scheduler Agent operation, perform the following steps:

1. Click **IBM® Z Workload Scheduler**→;**Workload**→;**Monitor**→;**Monitor Jobs**.
2. Select **All Jobs in plan** or another predefined task name.
3. Choose an engine name, or specify connection properties, and click **OK**.
4. Select a job and click **More Actions**→;**Kill**.

# Chapter 9. Administering an IBM i dynamic environment

On overview on how to administer the IBM Workload Scheduler IBM i dynamic environment.

To begin scheduling jobs with advanced options on IBM i agents, the agents must be configured.

## Scheduling on IBM i

### About this task

When scheduling a job on IBM i systems, the job launches a native command that can be either a system or a user command. The native command consists of SBMJOB system command, which launches a batch job. The native command starts one or more batch jobs. The batch jobs can be monitored only if they are started by the native command. The IBM i Agent Monitor can monitor a maximum of 130 batch jobs.

You can specify the name of the queue where the monitoring agent component runs by using the **MonitorQueueName** property in the native job launcher section of the `JobManager.ini` file. If you do not specify this property, the default queue (QBATCH) is used.

For more information, see the section about configuring properties of the native job launcher [NativeJobLauncher] in the *IBM Workload Scheduler: Administration Guide*.

Use the Dynamic Workload Console to check whether an IBM i job is waiting for a reply to a message. An IBM i job that is waiting for a message reply is in the SUSP (suspended) status. This status indicates that the job is running while waiting for input. When the input is received, the job status changes to EXEC (executing).

For more information about job statuses, see the section about status description and mapping for distributed jobs in the *Dynamic Workload Console User's Guide*.

If an IBM i job is waiting for a reply, you can view the message text and the related reply. This information is written into the correspondent IBM® Workload Scheduler job log so that the IBM® Workload Scheduler operator knows the exact message the IBM i job is waiting for.

When an IBM i job is waiting for a reply to a message, you can reply to the message directly from the **Monitor Workload** of the Dynamic Workload Console. The job in SUSP (suspended) status requires your attention on additional information to be displayed. A pop-up window shows the message that is waiting for your reply. Reply to the message in the pop-up window, then select one of the following actions:

#### Forward action

To forward your reply. A message in the pop-up window confirms that your reply was sent successfully.

#### Cancel action

To cancel your reply. The pop-up window is closed.

You can even define standard rules to automate the reply to the waiting messages. When defining an IBM i job, by using the Dynamic Workload Console specify the list of messages for which you want to set up an automated reply. For each message, specify:

**Message Id**

Message identifier.

**Message Text**

Text of the message.

**Message Reply**

An automated reply that you want to send.

For more information, see the section about defining an IBM i job in *User's Guide and Reference*.

## The agent joblog and TWSASPOOLS environment variable

**About this task**

By default, all information about the running of jobs is stored in the agent joblog. Most of this information usually consists of spool files. To select the spool file types that you want included in the agent joblog, use the **TWSASPOOLS** system variable, which works at IBM i agent level for any job to be submitted.

The **TWSASPOOLS** system variable forces the IBM i agent to either ignore all spool files or include one or more of them.

On the IBM i agent, create a new system level environment variable named TWSASPOOLS and set it to a list of the spool file types that are to be included. The list must begin with the SPOOLS: token.

For example, to force the IBM i agent to ignore all spool files, create the TWSASPOOLS variable as follows.

```
ADDENVVAR ENVVAR(TWSASPOOLS) VALUE(SPOOLS:) LEVEL(*SYS)
```

where the list after the SPOOL: token is empty. In this case, any agent joblog report for the IBM i agent is limited to the activity report that the Agent Monitor produces to trace its submission and monitoring action, and to the IBM i joblog of the Agent Monitor, which is always added at the end of the agent joblog.

To allow the IBM i agent to include only the QPRINT and the QPJOBLOG spool file types, that is, any spool files produced by printf instructions inside any ILE-C program and any produced joblog, create the TWSASPOOLS as follows:

```
ADDENVVAR ENVVAR(TWSASPOOLS) VALUE('SPOOLS: QPRINT QPJOBLOG') LEVEL(*SYS)
```

If the TWSASPOOLS variable already exists, change it as follows:

```
CHGENVAR ENVVAR(TWSASPOOLS) VALUE('SPOOLS: QPRINT QPJOBLOG') LEVEL(*SYS)
```

If any VALUE parameter is set to an incorrect string, the IBM i agent ignores the TWSASPOOLS environment variable option. You can create and change the TWSASPOOLS environment variable while with the IBM i agent active, but no workload activity must be running.

## Child job monitoring on IBM i agents

**About this task**

When you submit a command on an IBM i agent, the command might start one or more batch jobs. The IBM i agent monitors these batch jobs, which are referred to as child jobs.

When searching and monitoring any child jobs that are started, the IBM i agent uses a high percentage of its processing time.

If you know that your job scheduling does not start any child jobs or you have no interest in monitoring child jobs, you can instruct the IBM i agent to not search and monitor child jobs, and hence improve the performance of the agent.

You can exclude child job monitoring either at the agent level for all the commands or at the job definition level for a single command. If you want child job monitoring only for some specific submitted commands, you can set this option at the job definition level for a single command.

You can perform one or both of the following procedures to exclude or include child job monitoring:

#### Exclude child jobs from job monitoring at the agent level

By default child jobs are monitored. You can exclude child jobs from job monitoring for all submitted commands by creating the `TWS_NOCHILDS` system environment variable using the following IBM i system command:

```
ADDENVVAR ENVVAR(TWS_NOCHILDS) LEVEL(*SYS)
```

If the IBM i agent finds the `TWS_NOCHILDS` on the IBM i system, it does not monitor child jobs for any submitted command.

#### Exclude or include child jobs from job monitoring at the job definition level

You can exclude or include child jobs from job monitoring for a specific job by using `:NOCHILDS` or `:CHILDS` as ending tokens of the command string for the specific command.

- If you add the `:NOCHILDS` end token at the end of the native command you are submitting, the IBM i agent ignores any child jobs that are started by the command.
- If you add the `:CHILDS` end token at the end of the command you are submitting, the IBM i agent finds and monitors all the child jobs that are started by the command.



**Note:** The setting at job definition level overrides the setting at agent level.

#### Example

#### Examples

To monitor any child jobs that are started when the `PAYROLL` program is run, define the following command in the job definition:

- If the `TWS_NOCHILDS` system variable is defined on the IBM i system:

```
CALL PGM(MYLIB/PAYROLL) :CHILDS
```

- If the `TWS_NOCHILDS` system variable is not defined on the IBM i system:

```
CALL PGM(MYLIB/PAYROLL)
```

To not monitor any child jobs that are started when `MYSCHEDULE` program is run, define the following command in the job definition:

- If the `TWS_NOCHILDS` system variable is not defined on the IBM i system:

```
CALL PGM(MYLIB/MYSCHEDULE) :NOCHILDS
```

- If the `TWS_NOCHILDS` system variable is defined on the IBM i system:

```
CALL PGM(MYLIB/MYSCHEDULE)
```

## Information about child job monitoring on IBM i agent joblog

### About this task

If you include the child job monitoring on IBM i agent, as described in the section [Child job monitoring on IBM i agents on page 116](#), you can see information related to child job monitoring on the IBM i agent joblog.

Otherwise the information about the child job monitoring is not present in the joblog.

### Example

### Examples

This example shows the information related to child job monitoring included at job level for the `IBMI35C` job on the agent `D400`. The joblog shows the final status of 4 child jobs started from the submitted native command:

```
=====
=                               JOBLOG HEADER
=
= Occurrence name : AS400PGMCHILD
= Occurrence IA   : 2012/10/29 21:23
= Job name       : IBMI35C
= Work station   : D400
= Operation number: 002
= Start time    : 2012/10/31 10:23
= End time     : 2012/10/31 10:23
= Process ID    : 375602
= Duration     : 0.00.10
= Status       : ERROR
= Return code   : 30
= Hostname     : NC117025.ROMELAB.IT.IBM.COM
=
=====

The Dynamic Agent submitter-monitor job is qualified as:
  JobName=DYNAMICMON JobUser=ZOSDYN JobNumber=375602
Here follows the user command string
<CALL PGM(MINERMA/SBM4JOBS) :CHILDS>
2012/10/31 10:23:27.893 - Dynamic Agent job submitted the User Command
CALL PGM(MINERMA/SBM4JOBS)
```

```

The FOLLOWING 4 JOBS STARTED under the submitted User Command
  JobName=ZOSDYN      JobUser=ZOSDYN      JobNumber=375607
  JobName=ZOSDYN      JobUser=ZOSDYN      JobNumber=375609
  JobName=ZOSDYN      JobUser=ZOSDYN      JobNumber=375611
  JobName=ZOSDYN      JobUser=ZOSDYN      JobNumber=375612
Message CPF1241 (Success) received on MsgQueue ZOSDYN      QUSRSYS
  for the job ZOSDYN      ZOSDYN      375607
Message CPF1240 (Abend) received on MsgQueue ZOSDYN      QUSRSYS
  for the job ZOSDYN      ZOSDYN      375609
Message CPF1241 (Success) received on MsgQueue ZOSDYN      QUSRSYS
  for the job ZOSDYN      ZOSDYN      375611
Message CPF1241 (Success) received on MsgQueue ZOSDYN      QUSRSYS
  for the job ZOSDYN      ZOSDYN      375612
*** END codes gathered by the Monitor job ***
> END Status Code (Status): 0
> PROGRAM Return Code (Prc): 0
> USER Return Code (Urc): 0
  Urc was retrieved through SYSAPI

2012/10/31 10:23:37.904 - Dynamic Agent job ended monitoring the User Command
*** Return Code for submitted Command is 30 ***
*** job(s) started under User Command abended ***

```

This example shows the joblog for the IBMI35C job on the agent P400 when child job monitoring is excluded at job level:

```

=====
=                               JOBLOG HEADER
=
= Occurrence name : AS400PGMNOCHILD
= Occurrence IA   : 2012/11/07 03:49
= Job name        : IBMI35NC
= Work station    : P400
= Operation number: 002
= Start time      : 2012/11/07 16:48
= End time        : 2012/11/07 16:48
= Process ID      : 491329
= Duration        : 0.00.05
= Status          : COMPLETED
= Return code     : 0
= Hostname        : NC117025.ROMELAB.IT.IBM.COM
=
=====

The Dynamic Agent submitter-monitor job is qualified as:
  JobName=DYNAMICMON JobUser=ZOSDYN JobNumber=491329
Here follows the user command string
  <CALL PGM(MINERMA/SBM4JOBS) :NOCHILD>
2012/11/07 16:48:50.631 - Dynamic Agent job submitted the User Command
  CALL PGM(MINERMA/SBM4JOBS)
As per user choice, NO job started under the submitted command will be monitored
*** END codes gathered by the Monitor job ***
> END Status Code (Status): 0
> PROGRAM Return Code (Prc): 0
> USER Return Code (Urc): 0
  Urc was retrieved through SYSAPI

2012/11/07 16:48:55.685 - Dynamic Agent job ended monitoring the User Command

```

```
*** Return Code for submitted Command is 0 ***  
*** User Command ended successfully ***
```

## The agent return code retrieval

### About this task

The IBM i programming model was originally based on an early object orientation model in which programs communicated through message passing, rather than using return codes. The introduction of the Integrated Language Programming (ILE) model led to the definitions of common areas to exchange data as return codes in the same job environment: the user return codes and the system end codes.

For information about user return codes, see [Controlling the job environment with the user return code on page 120](#).

When the IBM i agent verifies that a submitted command or job is completed, it assigns a return code to the job based on the job status of the completed job. The return code is set depending on the completion message of the command or job. If the command or job completes successfully, the return code is set to 0. If the command or job does not complete successfully, the return code is set to the value of the severity of the message related to the exception that caused the abnormal end of the job. The IBM i agent can also set the return code to the value of the user return code when it is returned by the submitted command. If retrieved, the user return code is used as the value to set the return code.

The return code value assigned to the job is included in the IBM i agent joblog for the job and sent back to the scheduler user interface (WEB UI or z/OS ISPF panels) as return code, for compatibility reasons with agents on other operating systems.

## Controlling the job environment with the user return code

### About this task

With the introduction of the IBM i ILE model, it is possible to retrieve a value returned by a called program inside the same job.

When the Agent Monitor verifies that a submitted command is completed, it retrieves the following end of job codes using an IBM i System API:

#### **End status code or <Status> (0 if successful)**

It indicates if the system issued a controlled cancellation of the job. Possible values are:

**1**

the subsystem or the job itself is canceled.

**0**

the subsystem or the job itself is not canceled.

**blank**

the job is not running.



**Program return code or <Prc> (0000 if successful)**

It specifies the completion code of the last program (such as a data file utility program, or an RPG or COBOL program, invoked by the job).

If the job includes no program, the program return code is 0.

**User return code or <Urc> (0000 if successful)**

It specifies the user-defined return code set by ILE high-level language constructs. For example, the return code of a program written in C language.

It represents the most recent return code set by any thread within the job.

If the submitted command is a call to a user ILE program returning a value on exiting, this value is found in the Urc end of job code.

You can decide how to control the job environment of your submitted jobs by preparing the commands to be submitted as CALLs to your ILE programs, where the internal flow is controlled and the end status is decided through proper exit values. If a user program ends in error for an incorrect flow control, without returning a value, the Agent Monitor does not set the Return Code as user return code (Urc), but follows the criteria described in [The agent return code retrieval on page 120](#).

The following example shows an ILE C user program where two batch jobs are launched and a value of 10 is returned to the caller, regardless of the completion status of the batch jobs.

```
=====
#include <stdio.h>
#include <stdlib.h>
#include <string.h>
void main(int argc, char *argv[])
{
    int  EnvVarRC=0;
    printf("issuing SBMJOB CMD(CALL MYLIB/DIVBY0)...\\n");
    system("SBMJOB CMD(CALL MYLIB/DIVBY0)");
    printf("issuing SBMJOB CMD(WRKACTJOB OUTPUT(*PRINT))...\\n");
    system("SBMJOB CMD(WRKACTJOB OUTPUT(*PRINT)) LOG(4 0 *SECLVL)");
    exit(10);
    return;
}
=====
```

## Alternative method to set the user return code

**About this task**

In some IBM i environments, the system API retrieving the user return code (Urc) from the Agent Monitor code does not retrieve the correct value for Urc. It is therefore not recommended that you use any IBM i system APIs to retrieve the user return code. To receive a value returned by a called program, it is better to provide, instead, a parameter to receive the value.

Even if the Agent Monitor can retrieve the user return code using system API, an alternative user return code retrieval method was implemented in the Agent Monitor code. The alternative retrieval method has the following logic. The `USERRC` job

environment variable is created and set to the *INI* value before submitting the user command. When the command ends, the Agent Monitor retrieves its user return code using the system APIs, but it also verifies if the `USERRC` job environment variable was updated at user program level. If a value different from *INI* is found, this is considered as the user return code and the value retrieved using the system APIs is ignored because the user program modified the value of `USERRC` job environment variable.

The change of the `USERRC` variable at user program level requires the `USERRC` value change before exiting from the application user code. In the ILE C case, you can do this using the `putenv` statement, where the user return code is set to be returned.

The following example shows how the user code returns the user return code using the IBM i agent reserved job environment variable `USERRC`. This code was obtained from the code of the example in [Controlling the job environment with the user return code on page 120](#) by replacing the `exit` with the `putenv` statement.

```
=====
#include <stdio.h>
#include <stdlib.h>
#include <string.h>
void main(int argc, char *argv[])
{
    int    EnvVarRC=0;
    printf("issuing SBMJOB CMD(CALL MYLIB/DIVBY0)...\n");
    system("SBMJOB CMD(CALL MYLIB/DIVBY0)");
    printf("issuing SBMJOB CMD(WRKACTJOB OUTPUT(*PRINT))...\n");
    system("SBMJOB CMD(WRKACTJOB OUTPUT(*PRINT)) LOG(4 0 *SECLVL)");
    EnvVarRC = putenv("USERRC=10");
    return;
}
=====
```

## Configuring the agent on IBM i systems

An overview on how to configure the agent on IBM i systems.

The configuration settings of the agent are contained in the `JobManager.ini` file and in the `JobManagerGW.ini` file (for the path of these files, see the section about installation paths in *IBM Workload Scheduler: Planning and Installation*).

The configuration files are made up of many different sections. Each section name is enclosed between square brackets and each section includes a sequence of `variable = value` statements.

You can customize properties for the following:

- Log properties
- Trace properties when the agent is stopped. You can also customize traces when the agent is running using the procedure described in [Configuring trace properties when the agent is running on page 25](#).
- Native job executor
- Java™ job executor
- Resource advisor agent
- System scanner

On IBM i systems, the log messages are written in the following file:

```
TWA_DATA_DIR>/stdlist/JM/JobManager_message.log
```

On IBM i systems, the trace messages are written in the following files:

```
<TWA_DATA_DIR>/TWS/stdlist/JM/ITA_trace.log
<TWA_DATA_DIR>/TWS/stdlist/JM/JobManager_trace.log
<TWA_DATA_DIR>/TWS/stdlist/JM/javaExecutor0.log
```

Not all the properties in the `JobManager.ini` file and in the `JobManagerGW.ini` file can be customized. For a list of the configurable properties, see the following sections:

- [Configuring log message properties \[JobManager.Logging.cilog\] on page 22.](#)
- [Configuring trace properties when the agent is stopped \[JobManager.Logging.cilog\] on page 23.](#)
- [Configuring common launchers properties \[Launchers\] on page 28.](#)
- [Configuring properties of the native job launcher \[NativeJobLauncher\] on page 30.](#)
- [Configuring properties of the Java job launcher \[JavaJobLauncher\] on page 33.](#)
- [Configuring properties of the Resource advisor agent \[ResourceAdvisorAgent\] on page 34.](#)
- [Configuring properties of the System scanner \[SystemScanner\] on page 36](#)



**Note:** In the `JobManager.ini` file and in the `JobManagerGW.ini` file you must refer to Java 64 bit version.

## Configuring log message properties [JobManager.Logging.cilog]

### About this task

To configure the logs, edit the [JobManager.Logging.cilog] section in the `JobManager.ini` file. This procedure requires that you stop and restart the IBM Workload Scheduler agent

The section containing the log properties is named:

```
[JobManager.Logging.cilog]
```

You can change the following properties:

#### **JobManager.loggerhd.fileName**

The name of the file where messages are to be logged. the default value is

##### **On Windows operating systems**

```
TWA_home\stdlist\JM\JOBMANAGER-FFDC
```

##### **On UNIX operating systems**

```
$(TWA_DATA_DIR)/stdlist/JM/JobManager_message.log
```

#### **JobManager.loggerhd.maxFileBytes**

The maximum size that the log file can reach. The default is **1024000** bytes.

**JobManager.loggerhd.maxFiles**

The maximum number of log files that can be stored. The default is **3**.

**JobManager.loggerhd.fileEncoding**

By default, log files for the agent are coded in UTF-8 format. If you want to produce the log in a different format, add this property and specify the required codepage.

**JobManager.loggerfl.level**

The amount of information to be provided in the logs. The value ranges from 3000 to 7000. Smaller numbers correspond to more detailed logs. The default is **3000**.

**JobManager.ffdc.maxDiskSpace**

Exceeding this maximum disk space, log files collected by the first failure data capture mechanism are removed, beginning with the oldest files first.

**JobManager.ffdc.baseDir**

The directory to which log and trace files collected by the ffdc tool are copied. The default directory is

**On Windows operating systems**

```
TWA_home\stdlist\JM\JobManager_message.log
```

**On UNIX operating systems**

```
$(TWA_DATA_DIR)/stdlist/JM/JobManager_message.log
```

**JobManager.ffdc.filesToCopy**

Log and trace files (`JobManager_message.log` and `JobManager_trace.log`) collected by the ffdc tool located in `<TWA_home>\TWS\stdlist\JM`. The files are available in the following paths:

**On Windows operating systems**

- `TWA_home/TWS/stdlist/JM/JobManager_message.log`
- `TWA_home/TWS/stdlist/JM/JobManager_trace.log`

**On UNIX operating systems**

- `$(TWA_DATA_DIR)/stdlist/JM/JobManager_message.log`
- `$(TWA_DATA_DIR)/stdlist/JM/JobManager_trace.log`

When a message is logged (`JobManager.ffdc.triggerFilter = JobManager.msgIdFilter`) that has an ID that matches the pattern "AWSITA\*E" (`JobManager.msgIdFilter.msgIds = AWSITA*E`), which corresponds to all error messages, then the log and trace files (`JobManager.ffdc.filesToCopy = "/opt/IBM/TWA_<TWS_user>/TWS/stdlist/JM/JobManager_message.log" "/opt/IBM/TWA_<TWS_user>/TWS/stdlist/JM/JobManager_trace.log"`) are copied (`JobManager.ffdc.className = ccg_ffdc_filecopy_handler`) to the directory `JOBMANAGER-FFDC` (`JobManager.ffdc.baseDir = /opt/IBM/TWA_<TWS_user>/TWS/stdlist/JM/JOBMANAGER-FFDC`). If the files copied exceed 10 MB (`JobManager.ffdc.maxDiskSpace = 10000000`), then the oldest files are removed first (`JobManager.ffdc.quotaPolicy = QUOTA_AUTODELETE`).

After installing the z-centric agent or dynamic agent on Windows 2012, the `JobManager_message.log` might not be created. In this case, perform the following procedure:

1. Stop the agent.
2. Create a backup copy of `JobManager.ini`, and edit the original file by changing the row:

```
JobManager.loggerhd.className = ccg_multiproc_filehandler
```

to

```
JobManager.loggerhd.className = ccg_filehandler
```

3. Restart the agent.

## Configuring trace properties when the agent is stopped [JobManager.Logging.cclog]

How to configure the trace properties when the agent is stopped.

To configure the trace properties when the agent is stopped, edit the [JobManager.Logging] section in the `JobManager.ini` file and then restart the IBM Workload Scheduler agent.

The section containing the trace properties is named:

```
[JobManager.Logging.cclog]
```

You can change the following properties:

### **JobManager.trhd.fileName**

The name of the trace file. the default path is as follows:

#### **On Windows operating systems**

```
TWA_home/TWS/stdlist/JM/JobManager_trace.log
```

#### **On UNIX operating systems**

```
$(TWA_DATA_DIR)/stdlist/JM/JobManager_trace.log
```

### **JobManager.trhd.maxFileBytes**

The maximum size that the trace file can reach. The default is 10240000 bytes.

### **JobManager.trhd.maxFiles**

The maximum number of trace files that can be stored. The default is 5.

### **JobManager.trfl.level**

Determines the type of trace messages that are logged. Change this value to trace more or fewer events, as appropriate, or on request from IBM Software Support. Valid values are:

#### **DEBUG\_MAX**

Maximum tracing. Every trace message in the code is written to the trace logs.

**INFO**

All *informational*, *warning*, *error* and *critical* trace messages are written to the trace. The default value.

**WARNING**

All *warning*, *error* and *critical* trace messages are written to the trace.

**ERROR**

All *error* and *critical* trace messages are written to the trace.

**CRITICAL**

Only messages which cause the agent to stop are written to the trace.

The output trace (`JobManager_trace.log`) is provided in XML format.

After installing the z-centric agent or dynamic agent on Windows 2012, the `JobManager_trace.log` might not be created. In this case, perform the following procedure:

1. Stop the agent.
2. Create a backup copy of `JobManager.ini`, and edit the original file by changing the row:

```
JobManager.trhd.className = ccg_multiproc_filehandler
```

to

```
JobManager.trhd.className = ccg_filehandler
```

3. Restart the agent.

## Configuring trace properties when the agent is running

Use the **twstrace** command to set the trace on the agent when it is running.

Using the **twstrace** command, you can perform the following actions on the agent when it is running:

- [See command usage and verify version on page 25.](#)
- [Enable or disable trace on page 26.](#)
- Set the traces to a specific level, specify the number of trace files you want to create, and the maximum size of each trace file. See [Set trace information on page 26.](#)
- [Show trace information on page 26.](#)
- Collect trace files, message files, and configuration files in a compressed file using the command line. See [Collect trace information on page 27.](#)
- Collect trace files, message files, and configuration files in a compressed file using the Dynamic Workload Console. See the section about retrieving agent traces from the Dynamic Workload Console in *Troubleshooting Guide*.

You can also configure the traces when the agent is not running by editing the `[JobManager.Logging]` section in the `JobManager.ini` file as described in [Configuring the agent on page 18](#). This procedure requires that you stop and restart the agent.

## twstrace command

Use the **twstrace** command to configure traces, and collect logs, traces, and configuration files (ita.ini and jobManager.ini) for agents. You collect all the information in a compressed file when it is running without stopping and restarting it.

### See command usage and verify version

To see the command usage and options, use the following syntax.

#### Syntax

```
twstrace -u | -v
```

#### Parameters

**-u**

Shows the command usage.

**-v**

Shows the command version.

### Enable or disable trace

To set the trace to the maximum or minimum level, use the following syntax.

#### Syntax

```
twstrace -enable | -disable
```

#### Parameters

**-enable**

Sets the trace to the maximum level. The maximum level is **1000**.

**-disable**

Sets the trace to the minimum level. The minimum level is **3000**.

### Set trace information

To set the trace to a specific level, specify the number of trace files you want to create, and the maximum size the trace files can reach, use the following syntax.

#### Syntax

```
twstrace [ -level <level_number> ] [ -maxFiles <files_number> ] [ -maxFileBytes <bytes_number> ]
```

## Parameters

### **-level <level\_number>**

Sets the trace level. Specify a value in the range from 1000 to 3000, which is also the default value. Note that if you set this parameter to 3000, you have the lowest verbosity level and the fewest trace messages. To have a better trace level, with the most verbose trace messages and the maximum trace level, set it to **1000**.

### **-maxFiles <files\_number>**

Specify the number of trace files you want to create.

### **-maxFileBytes <bytes\_number>**

Set the maximum size in bytes that the trace files can reach. The default is **1024000** bytes.

## Show trace information

To display the current trace level, the number of trace files, and the maximum size the trace files can reach, use the following syntax.

## Syntax

**twstrace -level | -maxFiles | -maxFileBytes**

## Parameters

### **-level**

See the trace level you set.

### **-maxFiles**

See the number of trace files you create.

### **-maxFileBytes**

See the maximum size you set for each trace file

## Example

## Sample

The example shows the information you receive when you run the following command:

```
twstrace -level -maxFiles -maxFileBytes
```

```
AWSITA176I The trace properties are: level="1000",
max files="3", file size="1024000".
```

## Collect trace information

To collect the trace files, the message files, and the configuration files in a compressed file, use the following syntax.

## Syntax

**twstrace -getLogs [ -zipFile <compressed\_file\_name> ] [ -host <host\_name> ] [ -protocol {http | https} ] [ -port <port\_number> ] [ -iniFile <ini\_file\_name> ]**



## Parameters

### **-zipFile <compressed\_file\_name>**

Specify the name of the compressed file that contains all the information, that is logs, traces, and configuration files (ita.ini and jobManager.ini) for the agent. The default is **logs.zip**.

### **-host <host\_name>**

Specify the host name or the IP address of the agent for which you want to collect the trace. The default is **localhost**.

### **-protocol http|https**

Specify the protocol of the agent for which you are collecting the trace. The default is the protocol specified in the **.ini** file of the agent.

### **-port <port\_number>**

Specify the port of the agent. The default is the port number of the agent where you are running the command line.

### **-iniFile <ini\_file\_name>**

Specify the name of the **.ini** file that contains the SSL configuration of the agent for which you want to collect the traces. If you are collecting the traces for a remote agent for which you customized the security certificates, you must import the certificate on the local agent and specify the name of the **.ini** file that contains this configuration. To do this, perform the following actions:

1. Extract the certificate from the keystore of the remote agent.
2. Import the certificate in a local agent keystore. You can create an ad hoc keystore whose name must be **TWSSClientKeyStore.kdb**.
3. Create an **.ini** file in which you specify:
  - **0** in the **tcp\_port** property as follows:

```
tcp_port=0
```

- The port of the remote agent in the **ssl\_port** property as follows:

```
ssl_port=<ssl_port>
```

- The path to the keystore you created in Step 2 on page 129 in the **key\_repository\_path** property as follows:

```
key_repository_path=<local_agent_keystore_path>
```

## Configuring common launchers properties [Launchers]

### About this task

In the `JobManager.ini` file, the section containing the properties common to the different launchers (or executors) is named:

```
[Launchers]
```

The following properties are available:

### **BaseDir**

The installation path of the IBM Workload Scheduler agent. Do not modify this value.

### **CommandHandlerMinThreads**

Indicates the maximum number of commands that can be run on the agent concurrently. Limits to the number of jobs vary depending on the resources of your workstation, however consider that operations on comdhandler are usually short. The default is **20**. Usually, there is no need to modify this setting, even if you plan a very high workload on the agent. You might want to change it if many commands are run concurrently on the agent, for example, many concurrent requests to retrieve job logs.

### **CommandHandlerMaxThreads**

Indicates the maximum number of commands that can be run on the agent concurrently. Limits to the number of jobs vary depending on the resources of your workstation, however consider that operations on comdhandler are usually short. The default is **100**. Usually, there is no need to modify this setting, even if you plan a very high workload on the agent. You might want to change it if many commands are run concurrently on the agent, for example, many concurrent requests to retrieve job logs.

### **CpaHeartBeatTimeSeconds**

The polling interval in seconds used to verify if the **agent** process is still up and running. If the agent process is inactive the product stops also the **JobManager** process. The default is **30**. Modify only if you use dynamic pools with CPU-based requirements or optimization policies. With a lower value, the agent reacts quickly to CPU modifications, but this might cause unstable values in case of CPU spikes. Lower values causes a higher use of resources on the agent.

### **DirectoryPermissions**

The access rights assigned to the agent for creating directories when running jobs. The default is **0755**. Supported values are UNIX-format entries in hexadecimal notation.

### **DownloadDir**

The name of the directory where the fix pack installation package or upgrade elmage for IBM Workload Scheduler fault-tolerant agents or dynamic agents is downloaded during the centralized agent update process. If not specified, the following default directory is used:

#### **On Windows operating systems:**

```
TWA_home\TWS\stdlist\JM\download
```

#### **On UNIX operating systems:**

```
TWA_DATA_DIR/TWS/stdlist/JM/download
```

The centralized agent update process does not apply to z-centric agents.

### **ExecutorsMaxThreads**

Specifies the maximum number of jobs the dynamic agent can run concurrently. For example, to allow the dynamic agent to run a maximum of 500 jobs concurrently, set this parameter to **500**. The default is **400**.

**ExecutorsMinThreads**

Specifies the minimum number of jobs the dynamic agent can run concurrently. For example, to allow the dynamic agent to run a minimum of 500 jobs concurrently, set this parameter to **500**. The default is **38**. Modify if the number of expected concurrent jobs is much higher than 38. The agent dynamically allocates more threads if necessary, until it reaches the value specified in **ExecutorsMaxThreads**.

**FilePermissions**

The access rights assigned to the agent for creating files when running jobs. The default is **0755**. Supported values are UNIX-format entries in hexadecimal notation.

**MaxAge**

The number of days that job logs are kept (in path *TWA\_home/TWS/stdlist/JM*) before being deleted. The default is **30**. Possible values range from a minimum of 1 day.

**NotifierMaxThreads**

Notifier threads are in charge of notifying the dynamic workload broker of each status change in a job. This parameter specifies the maximum number of job status changes that can be notified to the dynamic workload broker.

**NotifierMinThreads**

Notifier threads are in charge of notifying the dynamic workload broker of each status change in a job. This parameter specifies the minimum number of job status changes that can be notified to the dynamic workload broker. The default value is **3**. Modify this parameters only in case of unexpected errors and after consulting with software support team.

**SpoolDir**

The path to the folder containing the jobstore and outputs. The default is:

**On Windows operating systems**

```
TWA_home/TWS/stdlist/JM
```

**On UNIX operating systems**

```
$(TWA_DATA_DIR/stdlist/JM
```

**StackSizeBytes**

The size of the operating system stack in bytes. The default is **DEFAULT**, meaning that the **agent** uses the default value for the operating system. Do not modify this parameter unless instructed to do so by the software support team. Incorrect values can cause the agent to crash.

## Configuring properties of the native job launcher [NativeJobLauncher]

**About this task**

In the `JobManager.ini` file, the section containing the properties of the native job launcher is named:

```
[NativeJobLauncher]
```

You can change the following properties:

#### **AllowRoot**

Applies to UNIX™ systems only. Specifies if the root user can run jobs on the agent. It can be `true` or `false`. The default is `false`. This property does not apply to IBM i, use the `AllowQSECOFR` option instead

#### **AllowQSECOFR**

Applies to IBM i systems only. Specifies if QSECOFR user can run jobs on the agent. It can be `true` or `false`. The default is `true`. Add a line like `AllowQSECOFR = false` to the `JobManager.ini` file to deny job execution to QSECOFR.

#### **CheckExec**

If `true`, before launching the job, the agent checks both the availability and the execution rights of the binary file. The default is `true`.

#### **DefaultWorkingDir**

Specifies the working directory of native jobs. You can also specify the value for the working directory when creating or editing the job definition in the Graphical Designer. When specified in the Graphical Designer, this value overrides the value specified for the **DefaultWorkingDir** property. If you do not specify any working directories, the `<TWS_home>\bin` directory is used.

#### **JobUnspecifiedInteractive**

Applies to Windows™ operating systems only. Specifies if native jobs are to be launched in interactive mode. It can be `true` or `false`. The default is `false`.

#### **KeepCommandTraces**

Set to `true` to store the traces of the method invocation for actions performed on a job definition, for example, when selecting from a picklist. These files are stored in the path `/opt/IBM/TWA_<TWS_user>/TWS/stdlist/JM/r3batch_cmd_exec`. The default setting is `false`.

#### **KeepJobCommandTraces**

Set to `true` to store the traces of the method invocation for actions performed on a job instance, for example, viewing a spool list. These files are stored in the `.zip` file of the job instance. The default setting is `true`.

#### **LoadProfile**

Applies to agents on Windows servers only. Specifies if the user profile is to be loaded. It can be `true` or `false`. The default is `true`.

#### **MonitorQueueName**

Specifies the name of the queue where the IBM i jobs are monitored. If you do not specify this property, the default queue (QBATCH) is used.

#### **PortMax**

The maximum range of the port numbers used by the task launcher to communicate with the Job Manager. The default is 0, meaning that the operating system assigns the port automatically.

**PortMin**

The minimum range of the port numbers used by the task launcher to communicate with the Job Manager. The default is 0, meaning that the operating system assigns the port automatically.

**PostJobExecScriptPathName**

The fully qualified path of the script file that you want to run when the job completes. By default, this property is not present in the `JobManager.ini` file. If you do not specify any file path or the script file doesn't exist, no action is taken.

This property applies to dynamic agent and z/OS agent. For details about running a script when a job completes, see *User's Guide and Reference*.

**PromotedNice**

Used in workload service assurance. This property is not supported on the Agent for z/OS.

For UNIX and Linux operating systems only, assigns the priority value to a critical job that needs to be promoted so that the operating system processes it before others. Applies to critical jobs or predecessors that need to be promoted so that they can start at their critical start time.

Boundary values vary depending upon each specific platform, but generally lower values correspond to higher priority levels and vice versa. The default is -1.

Be aware that:

- The promotion process is effective with negative values only. If you set a positive value, the system runs it with the -1 default value.
- An out of range value (for example -200), prompts the operating system to automatically promote the jobs with the lowest allowed nice value.
- Overusing the promotion mechanism (that is, defining an exceedingly high number of jobs as mission critical and setting the highest priority value here) might overload the operating system, negatively impacting the overall performance of the workstation.

**PromotedPriority**

Used in workload service assurance. This property is not supported on the Agent for z/OS.

For Windows operating systems only, sets to this value the priority by which the operating system processes a critical job when it is promoted. Applies to critical jobs or predecessors that need to be promoted so that they can start at their critical start time. Valid values are:

- High
- AboveNormal (the default)
- Normal
- BelowNormal
- Low Or Idle

Note that if you set a lower priority value than the one non-critical jobs might be assigned, no warning is given.

### RequireUserName

When `true`, requires that you add the user name in the JSDL job definition.

When `false`, runs with the user name used by job manager, that is:

- `TWS_user` on UNIX™ and Linux™ systems
- The local system account on Windows™ systems

The default is `false`.

### RunExecutablesAsIBMiJobs

If you set this property to `true`, you can define IBM i jobs as generic jobs without using the XML definition. Generic jobs are automatically converted to IBM i jobs. As a side effect, generic jobs cannot be run when this parameter is enabled (`RunExecutablesAsIBMiJobs=true`). There is no default value because this property is not listed in the `JobManager.ini` file after the agent installation.

If you set this property to `true`, ensure that the user you used to install the agent has been granted the `*ALLOBJ` special authority.

### RunInteractiveJobOnInvalidSession

Applies only to native and executable jobs starting interactive programs running on dynamic agents installed on Windows operating systems. Interactive programs run only if the job user has an active session open when the job runs. If there is no active session for the job user, the job behavior is defined by this property, as follows. Set the property to `true` to enable jobs to start interactive programs even if there is no active session for the job user. Set the property to `false` to prevent jobs from starting interactive programs if there is no active session for the job user.

### ScriptSuffix

The suffix to be used when creating the script files. It is:

`.cmd`

For Windows™

`.sh`

For UNIX™

### VerboseTracing

Enables verbose tracing. It is set to `true` by default.

## Configuring properties of the Java™ job launcher [JavaJobLauncher]

### About this task

In the `JobManager.ini` file, the section containing the properties of the Java™ job launcher is named:

```
[JavaJobLauncher]
```

You can change the following property:

### JVMOptions

The options to provide to the Java™ Virtual Machine used to start job types with advanced options. Supported keywords for establishing a secure connection are:

- `https.proxyHost`
- `https.proxyPort`

Supported keywords for establishing a non-secure connection are:

- `Dhttp.proxyHost`
- `Dhttp.proxyPort`

For example, to set job types with advanced options, based on the default JVM http protocol handler, to the unauthenticated proxy server called with name `myproxyserver.mycompany.com`, define the following option:

```
JVMOptions = -Dhttp.proxyHost=myproxyserver.mycompany.com -Dhttp.proxyPort=80
```

## Configuring properties of the Resource advisor agent [ResourceAdvisorAgent]

### About this task

In the `JobManager.ini` and `JobManagerGW.ini` files, the section containing the properties of the Resource advisor agent is named:

```
[ResourceAdvisorAgent]
```

You can change the following properties:

### BackupResourceAdvisorUrls

The list of URLs returned by the IBM Workload Scheduler master in a distributed environment or by the dynamic domain manager either in a z/OS or in a distributed environment. The agent uses this list to connect to the master or dynamic domain manager.

### CPUScannerPeriodSeconds

The time interval that the Resource advisor agent collects resource information about the local CPU. The default value is every 10 seconds.

### FullyQualifiedHostname

The fully qualified host name of the agent. It is configured automatically at installation time and is used to connect with the master in a distributed environment or with the dynamic domain manager in a z/OS or in a distributed environment. Edit only if the host name is changed after installation.

**NotifyToResourceAdvisorPeriodSeconds**

The time interval that the Resource advisor agent forwards the collected resource information to the Resource advisor. The default value is every 119 seconds.

**ResourceAdvisorUrl****JobManager.ini**

The URL of the master in a distributed environment, or of the dynamic domain manager in a z/OS or in a distributed environment, that is hosting the agent. This URL is used until the server replies with the list of its URLs. The value is `https://$(tdwb_server):$(tdwb_port)/JobManagerRESTWeb/JobScheduler/resource`, where:

**\$(tdwb\_server)**

is the fully qualified host name of the master in a distributed environment or of the dynamic domain manager either in a z/OS or in a distributed environment.

**\$(tdwb\_port)**

is the port number of the master in a distributed environment or of the dynamic domain manager either in a z/OS or in a distributed environment.

It is configured automatically at installation time. Edit only if the host name or the port number are changed after installation, or if you do not use secure connection (set to `http`). If you set the port number to zero, the resource advisor agent does not start. The port is set to zero if at installation time you specify that you will not be using the master in a distributed environment or the dynamic domain manager either in a z/OS or in a distributed environment.

In a distributed environment, if **-gateway** is set to either `local` or `remote`, then this is the URL of the dynamic agent workstation where the gateway resides and through which the dynamic agents communicate. The value is `https://$(tdwb_server):$(tdwb_port)/ita/JobManagerGW/JobManagerRESTWeb/JobScheduler/resource`, where:

**\$(tdwb\_server)**

The fully qualified host name of the dynamic agent workstation where the gateway resides and through which the dynamic agent communicates with the dynamic workload broker.

**\$(tdwb\_port)**

The port number of the dynamic agent workstation where the gateway resides and through which the dynamic agent communicates with the dynamic workload broker.

**JobManagerGW.ini**

In a distributed environment, if **-gateway** is set to `local`, then **ResourceAdvisorUrl** is the URL of the master or dynamic domain manager. The value is `https://$(tdwb_server):$(tdwb_port)/JobManagerRESTWeb/JobScheduler/resource`, where:



**`$(tdwb_server)`**

The fully qualified host name of the master or dynamic domain manager.

**`$(tdwb_port)`**

The port number of the master or dynamic domain manager.

**ScannerPeriodSeconds**

The time interval that the Resource advisor agent collects information about all the resources in the local system other than CPU resources. The default value is every 120 seconds.

The resource advisor agent, intermittently scans the resources of the machine (computer system, operating system, file systems and networks) and periodically sends an update of their status to the master or dynamic domain manager either in a z/OS or in a distributed environment.

The CPU is scanned every `CPUScannerPeriodSeconds` seconds, while all the other resources are scanned every `ScannerPeriodSeconds` seconds. As soon as one of the scans shows a significant change in the status of a resource, the resources are synchronized with the master in a distributed environment or the dynamic domain manager either in a z/OS or in a distributed environment. The following is the policy followed by the agent to tell if a resource attribute has significantly changed:

- A resource is added or deleted
- A string attribute changes its value
- A CPU value changes by more than `DeltaForCPU`
- A file system value changes by more than `DeltaForDiskMB` megabytes
- A Memory value changes by more than `DeltaForMemoryMB` megabytes

If there are no significant changes, the resources are synchronized with the IBM Workload Scheduler master in a distributed environment or with the dynamic domain manager either in a z/OS or in a distributed environment every `NotifyToResourceAdvisorPeriodSeconds` seconds.

## Configuring properties of the System scanner [SystemScanner]

### About this task

In the `JobManager.ini` file, the section containing the properties of the System scanner is named:

```
[SystemScanner]
```

You can change the following properties:

**CPUSamples**

The number of samples used to calculate the average CPU usage. The default value is 3.

**DeltaForCPU**

The change in CPU usage considered to be significant when it becomes higher than this percentage (for example, DeltaForCPU is 20 if the CPU usage changes from 10 percent to 30 percent). The default value is 20 percent.

**DeltaForDiskMB**

The change in use of all file system resources that is considered significant when it becomes higher than this value. The default value is 100 MB.

**DeltaForMemoryMB**

The change in use of all system memory that is considered significant when it becomes higher than this value. The default value is 100 MB.

## Configuring to schedule job types with advanced options

**About this task**

You can define job types with advanced options by using the related configuration files. The options you define in the configuration files apply to all job types with advanced options of the same type. You can override these options when defining the job by using the Dynamic Workload Console or, if you are in a distributed environment, the **composer** command.

Configuration files are available on each dynamic agent in TWA\_home/TWS/JavaExt/cfg for the following job types with advanced options:

**Table 4. Configuration files for job types with advanced options**

Job type	File name	Keyword
<ul style="list-style-type: none"> <li>• Database job type</li> <li>• MSSQL Job</li> </ul>	DatabaseJobExecutor.properties	<p>Use the <code>jdbcdDriversPath</code> keyword to specify the path to the JDBC drivers. Define the keyword so that it points to the JDBC jar files directory, for example:</p> <pre style="background-color: #f0f0f0; padding: 5px;">jdbcdDriversPath=c:\\mydir\\jars\\jdbc</pre> <p>The JDBC jar files must be located in the specified directory or its subdirectories. Ensure you have list permissions on the directory and its sub subdirectories.</p> <p> <b>Note:</b> For the MSSQL database, use version 4 of the JDBC drivers.</p>
Java™ job type	JavaJobExecutor.properties	Use the <code>jarPath</code> keyword to specify the path to the directory where the jar files are stored.

**Table 4. Configuration files for job types with advanced options (continued)**

Job type	File name	Keyword
		This includes all jar files stored in the specified directory and all sub directories.
J2EE job type	J2EEJobExecutorConfig.properties	For more information about the J2EE job type, see the topic about configuring to schedule J2EE jobs in the <i>IBM Workload Scheduler: Administration Guide</i> .

## Customizing the SSL connection between IBM i agents and the Z controller when using your certificates

Customizing the SSL connection between IBM i agents and the Z controller when using your certificates.

### About this task

The communication between IBM i agents and the Z controller to which they are registered to is, by default, in http. If you are using your own certificates, to enable an https communication you must customize the agent certificates and the configuration file by performing the following steps:

1. Generate a random file.
2. Generate a PEM file containing the private key of the agent and call it `ita_prv<suffix>.pem`. The IBM Workload Scheduler default PEM file is called **ita\_prvtws.pem**.
3. Save the password of the agent private key in a stash file (`.sth` file).
4. Generate another PEM file and call it `ita_pub<suffix>.pem`. It must contain the certificate for the agent private key.
5. Create a copy of the file created in Step 4 on page 139 and call it `ita_cert<suffix>.pem`.
6. Generate another PEM file and call it `ita_ca_cert<suffix>.pem`. This file must contain the certificate of both the agent and the Z controller or the dynamic domain manager to which the agent is connected.
7. Open the `ita.ini` agent configuration file and set the values appropriate for your environment in the following properties:

```
password_file=<stash_file_fullpath>
random_file=<random_file_fullpath>
cert_label=<label_agent_private_key>
key_db_name=<suffix>
key_repository_dir=<directory_ita_*<suffix>.pem>
tcp_port=0
ssl_port=<ssl_port_value>
```

Where:

**stash\_file\_fullpath**

Specify the fully qualified path to the stash file that contains the agent private key password. This is the file that you created in the [Step 3 on page 139](#). The default value is `/opt/IBM/TWA_<TWS_user>/TWS/ITA/cpa/ita/cert/password.sth`.

**random\_file\_fullpath**

Specify the fully qualified path to the random file. This is the file that you created in the [Step 1 on page 139](#). The default value is `/opt/IBM/TWA_<TWS_user>/TWS/ITA/cpa/ita/cert/TWS.rnd`.

**label\_agent\_private\_key**

Specify the label of the agent private key. The default is **client**.

**suffix**

Specify the suffix you used in the names of all the files that you generated. The default product value is **tws**.

**directory\_ita\_<suffix>.pem**

Specify the directory that contains all the .pem files that you generated. The default directory is `/opt/IBM/TWA_<TWS_user>/TWS/ITA/cpa/ita/cert`.

**tcp\_port\_value**

Specify **0** as TCP/IP port value.

**ssl\_port\_value**

Specify the *tcp\_port\_value*. For example, if the TCP/IP port value was 31114, specify 31114.

- 8. Stop the IBM i agent by using the following command:

```
ShutDownLwa
```

- 9. Start the IBM i agent by using the following command:

```
StartUpLwa
```

After you complete the procedure, depending on the SSL storing certificate method you use, import the certificates in a RACF KEYRING or in a keystore created in the UNIX System services. Depending on the method you use refer either to the RACF or the Unix System services documentation.

# Chapter 10. Monitoring and recovering jobs

This chapter contains the following sections.

## IBM Z Workload Scheduler Agent job status notifications

Notifications about the change of status of running jobs are returned to the HTTP server subtask by the Tivoli® agent. [Table 5: Job status change notifications on page 141](#) shows the possible status changes for jobs running on IBM Z Workload Scheduler Agents.

**Table 5. Job status change notifications**

Notification	New operation status	Explanation
Submitted (POST executed)	S	Post executed (from local HTTP client)
Submitted	S	Agent launched the job
Canceled	E (+ CAN)	Job canceled by command
Executing	S	Job started execution
Failed_Execution	E (+ error code)	Job ended in error
Succeeded_Execution	C	Job completed successfully
Failed_Submission	E (+ OSUB)	Job submission failed
Unknown_Execution	E (+ CCUN)	Agent lost track of the job

## Setting up and running automatic recovery for IBM Z Workload Scheduler Agent jobs

IBM Z Workload Scheduler supports the use of automatic recovery statements in IBM Z Workload Scheduler Agent scripts.

When you create or edit an IBM Z Workload Scheduler Agent script, start the lines where you specify the automatic recovery statements with `/** OPC`, `/**%OPC`, or `/**>OPC`. These lines are removed before the script is downloaded onto the IBM Z Workload Scheduler Agents.

You can run the following recovery actions on IBM Z Workload Scheduler Agent jobs:

- Restart the current occurrence at the failed operation, with or without JCL changes.
- Restart the current occurrence at another operation.
- Add occurrences of special recovery applications. Make the restart of the failed occurrence dependent on the completion of the recovery occurrences.
- Release a dependent occurrence.

Data set cleanup is not available.

## Automatic-recovery-control statement for IBM Z Workload Scheduler Agent scripts

Each automatic-recovery-control statement describes an error situation and the recovery actions for it.

Use the following rules to create RECOVER statements:

- Each statement must begin in a new 80-byte logical record.

The symbols `/**%OPC` must appear in bytes 1 to 7 and be followed by at least one blank, where:

```
/**%OPC RECOVER
```

Identifies a RECOVER statement.

```
/**%OPC
```

Identifies a RECOVER continuation statement.

The automatic recovery function also inserts informational statements in the JCL:

```
/** OPC
```

Identifies a message statement.

```
/**>OPC
```

Identifies a comment statement.

- You cannot use variables anywhere in the RECOVER statement.
- The parameters are optional; you can code them in any sequence.
- Each parameter consists of a keyword followed by an equals sign and variable information.
- Parameters are separated by commas.
- You cannot code the same keyword more than once on the same statement.
- If you code only one parameter value, you do not need to enclose it in parentheses; for example, `JOBPCODE=PCHK`.
- Bytes 72 to 80 are ignored by the automatic recovery function.
- When the total length of fields on a control statement exceeds 71 bytes, continue the statement using the following continuation conventions:
  - Interrupt the field after a complete or partial parameter, including the comma that follows it, before byte 72.
  - Code the identifying continuation characters `/**%OPC` followed by at least one blank in bytes 1 to 7 of the statement that follows.
  - Continue the interrupted operand in any position from bytes 9 to 16.
- Limit the RECOVER statement to one card (avoid continuation).

### RECOVER statement syntax

The syntax of the RECOVER statement follows. These are the only RECOVER parameters that apply to the IBM Z Workload Scheduler Agent workstation.

For a complete list of the RECOVER parameters, see *Managing the Workload*.

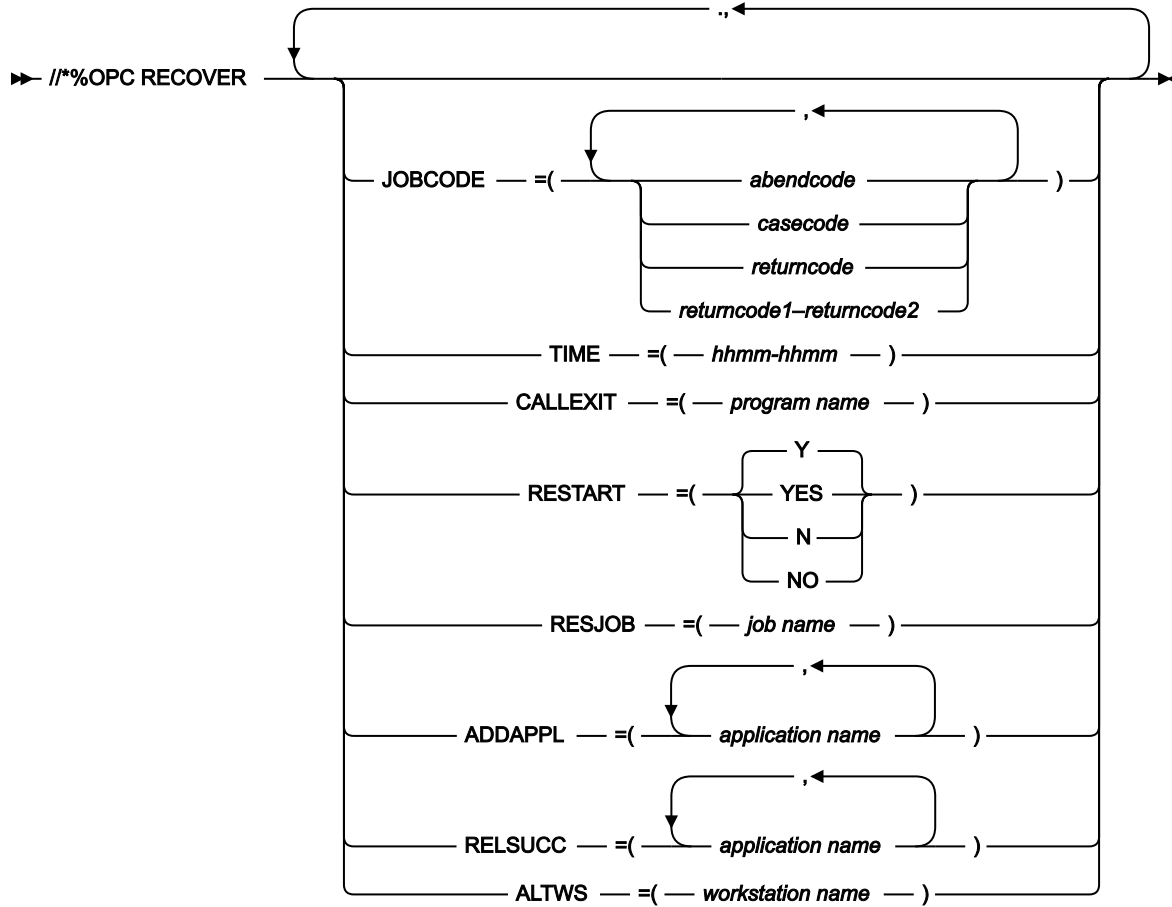

## Statement parameters

All the parameters for the RECOVER statement are optional. For IBM Z Workload Scheduler Agent jobs, the available RECOVER statement categories are Selection and Recovery action.

## Selection parameters

Selection parameters for error situations managed by the recover statement.

These selection parameters specify the error situations that the RECOVER statement manages:

### **JOBCODE**

Restricts the RECOVER statement to be valid only for those job completion codes and return codes specified.

### **TIME**

Restricts the RECOVER statement to be valid only in the time range specified.



**Note:** Review the EXCLUDECC and EXCLUDERC parameters of the AROPTS statement, which specify codes for which no automatic recovery is done. For information about AROPTS, see *Customization and Tuning*.

## Recovery action parameters

The following recovery action parameters specify the actions to take for recovery:

### **RESTART**

Specifies if the occurrence is to be restarted.

### **RESJOB**

Specifies the name of the job from which the occurrence must be rerun.

### **ADDAPPL**

Specifies an application or a list of applications to be added as occurrences in the current plan.

### **RELSUCC**

Specifies the application ID of a successor occurrence, or a list of IDs.

### **ALTWS**

Specifies the name of an alternate workstation on which to run the operation.

## Selection parameters

When a job ends in error, this information is available:

- Job name
- Abend code, if job abended
- Return code, if job did not abend

The selection parameters use this information:

### **JOBCODE**

The code can be an abend code, an error code set by IBM Z Workload Scheduler or JCC, a case code, a return code, or a return code range. The values are those given as the error code on the Handling Operations Ended in Error panel in the Modify Current@ Plan panel.

The JOBCODE keyword values are:

#### **Sxxx**

Specifies a system abend code.

#### **Uxxx**

Specifies a user abend code.



**xxxx**

Specifies a case code or an error code set by IBM Z Workload Scheduler, either directly or by using the job completion checker.

**n**

Specifies a return code.

**x-y**

Specifies a return code range, where *x* and *y* represent positive decimal values.

The codes specified in the `JOBCODE` parameter are tested against the job code as set by IBM Z Workload Scheduler when the job ends.

You can also specify abend codes in generic form. Therefore, an asterisk (\*) can represent any character, or any group of characters, in those positions where it is placed. A code can contain more than one asterisk only if each asterisk is separated from the next by another character.



**Note:** The `JOBCODE=*` notation covers all possible user and system abend codes; it does not cover return codes. To cover all possible return codes, specify a return code range in the form:

```
JOBCODE=x-y
```

where *x* and *y* represent positive decimal values.

A return code cannot be greater than 4095. To specify a range of values, set *x* to the lower value and *y* to the higher value. To specify all return codes greater than or equal to a certain value, set *x* to that value and *y* to 4095.

**TIME**

The time is specified in the form *hhmm*, where *hh* is the hour from 00 to 24, and *mm* is the minute from 00 to 60. This is the time when the recovery is automatic.

For example:

**TIME=0700-1600**

No recovery actions occur between 4 p.m. and 7 a.m.

**TIME=2200-0800**

IBM Z Workload Scheduler does automatic recovery only between 22.00 and 8.00.

**TIME=0000-2400**

Recovery can be automatic at any time.

**TIME=0000-0000**

Recovery is not started unless there is manual intervention.

The recovery actions for a job that remains in the ended-in-error list can be manually started up later. Such requests override any TIME value specified.

Default: The recovery specification is for the time range specified by the STARTIME and ENDTIME keywords of the AROPTS automatic recovery options statement. For more details, see *Customization and Tuning*.

## Action parameters

The following parameters specify the action that IBM Z Workload Scheduler must take when the recovery statement is invoked.

### RESTART

RESTART=Y causes the job to be rerun, either from the failing operation or, if you specified RESJOB, from an earlier operation within the occurrence.

RESTART=N prevents the restart. It can be used with ADDAPPL when the recovery actions are to be done by a separate application. It can also be used to select cases for which no recovery should be performed or when testing the recovery procedure. The operation remains in ended-in-error status.

Default: RESTART=Y.

### RESJOB

The RESJOB parameter handles failures at an occurrence level, not within the failing job itself.

The occurrence of the application is rerun from the first preceding computer workstation operation, whose name matches the job name specified in the RESJOB parameter. If the job name specified cannot be found in a computer operation preceding the failed operation in the same occurrence, no automatic recovery occurs and the job remains in the error handling list with an extended status code indicating an automatic recovery error.

The indicated operation must be a predecessor to the failed operation or be the failed operation itself.



**Note:** External successors cannot be handled automatically. Therefore the set of operations selected for rerun that can be completed at failure time must not have any external successors.

The rerun operation must be defined on an automatically reporting computer workstation.

The parameter is ignored if RESTART=N is specified.

Default: Rerun from the failed operation.

### ADDAPPL

Here you specify a list of applications. Occurrences of these applications are added to the current plan if this RECOVER statement is invoked.

- If RESTART=N is specified, the applications are independent of the failed occurrence.
- If RESTART=Y is specified, the recovery applications are added to the current plan as predecessors to the failing operation or, if RESJOB is specified, to the operation where restart is being attempted.

Added applications are independent of each other. A maximum of 40 application occurrences can be added.

For example, suppose a database update fails. A rerun of the failed job is necessary but must be postponed to a later time. However, a database restore job must be run to repair the database before the online users require the database. This recovery situation can be specified as:

```
//*%OPC RECOVER JOBCODE=SCHK,RESTART=N,ADDAPPL=A301RORG
```

This means that, on case code SCHK, do not rerun the failing operation. However, add an occurrence of the application A301RORG to the current plan, without a dependency to the failing operation and leave the failing operation in ended-in-error status.

Default: No application occurrences are added.



**Note:**

1. When automatic recovery adds an occurrence to the current plan, input arrival and deadline times are not taken from the application description. Instead the occurrence is given an input arrival of the time the add is run, according to the time on the z/OS® system where the controller is started and the deadline is set for 8 hours after input arrival. If an occurrence of that application already exists with this input arrival time, then one minute is added to the time until a time is reached when the occurrence can be included. If the added occurrence includes time-dependent operations with specific input arrival times, then the operations are started at the specified time.
2. An occurrence that has been added to the current plan by automatic job recovery does not become the predecessor to an occurrence that is added later by daily planning, even if normal dependency criteria are met.

## RELSUCC

This parameter specifies which external successors to the failing operation are allowed to run even if their predecessor operation has ended in error.

The external successors to the failing operation are checked, and the dependencies between the failed operation and the specified successors are deleted at recovery time.

The effect is that this predecessor (the failed operation) is reported as complete to the external successor, and the successor-predecessor chaining is removed. The external successor becomes ready if its other predecessors are completed. The dependency does not exist when the failed occurrence is rerun.

Even if one successor is released, other successors might be waiting for the failed occurrence to complete. These might be successors not yet in the current plan. Assume that W is a weekly application and D is a daily application that is dependent on W. If W fails and there is a RECOVER statement causing the release of that day's D, the occurrence of D the next day also waits for W to complete, but without any automatic release.

You can specify a maximum of 40 application IDs.

Default: None.

**ALTWS**

Specifies the name of an alternate workstation on which to run the operation. The ALTWS parameter overrides the alternate workstation defined in the workstation description. You can use this parameter, for example, with the TIME parameter to specify alternate workstations for an operation, depending on the time of day.

Default: None.

## Chapter 11. Running a script when a job completes

In many scenarios, when a job completes, you might want to run one or more actions, by using the information related to the job completion. For this purpose, you can write a script file and store it in a directory of the agent file system. The script is run every time that a job completes, either successfully or unsuccessfully. The script runs with the same credentials as the agent user that is running the job.



**Note:** The agent user must be authorized to access the script file and its directory.

To provide IBM Workload Scheduler with the path of the script file, you must modify the `JobManager.ini` file as follows:

1. Locate the `JobManager.ini` file on the local agent instance where the script will run. The file is located in the `TWA_home/TWS/ITA/cpa/config` directory on the agent.
2. In the `[NativeJobLauncher]` section of the file, define the value of the **PostJobExecScriptPathName** property, with the fully qualified path of the script file that you want to run when a job completes.
3. Save the changes to the file.

If you do not specify any file path or the script file doesn't exist, no action is taken when the job completes. For details about customizing the **PostJobExecScriptPathName** property, see *Administration Guide*.

The following job variables can be used in the script:

- JOB\_ID
- JOB\_ALIAS
- JOB\_SPOOL\_DIR
- JOB\_STATUS
- JOB\_RETURN\_CODE
- JOB\_DURATION
- JOB\_START\_TIME
- JOB\_END\_TIME

The script is run for any of the following job final statuses:

- SUCCEEDED\_EXECUTION
- UNKNOWN
- CANCELLED
- FAILED\_EXECUTION

In the `JobManager_message.log`, you are notified via a message if the job started successfully, or if any error prevented the job from starting. To analyze the output of the script execution, you can check the `out.log` file in the `post_script` subdirectory of the job `SpoolDir`.

# Chapter 12. Viewing the job logs from the host

An overview on how to view or retrieve the job logs issued in the z-centric environment and how to attach a header with job run information on top of each log.

There are two ways of retrieving the job logs:

- You can manually request to browse the log of a specific job (on demand) or have automatically displayed the logs of jobs that ended in error. To browse the log you can use any of the available user interfaces (ISPF dialogs, Dynamic Workload Console, or programming interfaces).

To specify the job log retrieval policy (on demand, or automatic for ended-in-error), define the `JOBLOGRETRIEVAL` keyword in the `HTTPOPTS` initialization statement. See *IBM Z Workload Scheduler: Customization and Tuning*.

- You can activate the [Output collector on page 152](#) started task to have the logs of all jobs, independently of their outcome, sent to the JES spool to be picked up by an external output management product.

On all the job logs originated from the z-centric environment you can customize IBM® Z Workload Scheduler so that a [header on page 150](#) is added automatically at the top of the job log with the information necessary to classify the output (occurrence name, occurrence IA, job name, workstation name, operation number, start time, end time) and information about the run (process ID, return code, duration, status, hostname).



**Remember:** to have the job log header mechanism functioning for workload run on dynamic agents, the dynamic agents must be running at least version 8.6.0.1 of IBM Workload Scheduler.

## Customizing the job log header

A sample job log header template is downloaded on IBM® Z Workload Scheduler at installation time. You can customize it to fit it to your preferences.

When you customize the `JLOGHDRTEMPL` keyword of the `HTTPOPTS` initialization statement, you command the system to add a header containing run-related information to every job log released in the z-centric environment.

The header format can be personalized. The information displayed in the header is added depending on how you customize the header template sample that comes with the installation of IBM® Z Workload Scheduler and which predefined variables that describe the job and its run are featured in the header.

When you create the sample job JCL with the `EQQJOBS` installation aid, the following job log header template sample is added to the samples library that you specified in the `EQQJOBS` panels:

```
=====
=                               JOBLOG HEADER                               =
=
= Occurrence name : ${occname}
= Occurrence IA   : ${IAYYYY}/${IAMM}/${IADD} ${IAhh}:${IAMm}
= Job name        : ${jobname}
= Work station    : ${wsname}
= Operation number: ${opernum}
```

```

= Start time      : ${SYYYY}/${SMM}/${SDD} ${Shh}:${Smm}
= End time       : ${EYYYY}/${EMM}/${EDD} ${Ehh}:${Emm}
= Process ID     : ${processid}
= Duration       : ${duration}
= Status         : ${status}
= Return code    : ${returncode}
= Hostname       : ${hostname}
=
=====

```

You can then edit and copy the sample to a PARM library that must be pointed to by the JLOGHDRTEMPL keyword of the HTTPOPTS initialization statement.

The properties of the predefined variables provided in the sample are described in the following table. When you customize the sample, you can select the variables that you deem useful or retain them all.

**Table 6. The predefined variables of the sample job log header template.**

Variable	Name	Length	Value is...
Occurrence name	occname	16	sent at job submission
Occurrence input arrival time	IAYYYY IAMM IADD IAhh IAmm		sent at job submission
Job name	jobname	8	sent at job submission
Workstation	wsname	4	sent at job submission
Operation number	opernum	2	sent at job submission
Start time	SYYYY SMM SDD Shh Smm		local on agent
End time	EYYYY EMM EDD Ehh Emm		local on agent
Process ID	processid		local on agent
Duration	duration		local on agent
Status	status		local on agent
Return code	returncode		local on agent; NOERROR actions are ignored and not truncated to 4 characters
Hostname	hostname		local on agent; hostname of the agent where the job ran

The syntax for the job log header variables is consistent with the syntax used for variable substitution in the z-centric environment, that is:

```

${variable_name}

```



**Important:** The template sample is in the IBM-37 codepage. The brace characters ({ and }) are mapped differently depending on the codepage. If you use a different codepage to view the template, you are very likely to need to correct the variables syntax.

Only simple variable substitution is allowed, no compound variables are supported. If the variable name is incorrect, the variable is left unresolved.

You can also use variables to compose the run dates. The dates are based on the local time of the controller.

## Collecting job logs with Output collector

An overview on the mechanism that automatically retrieves the logs of jobs and dynamic jobs run on IBM Z Workload Scheduler Agents and copies them to the JES spool so that they can be processed by an external output management product.

The standard log management process for jobs running in the z-centric environment is to be requested manually, with an exception for the logs of jobs that ended in error that can be received semi-automatically. In addition to this, or as an alternative, you can activate the Output collector started task, which automatically retrieves the log of every job run in the z-centric environment and sends it to the JES spool so that it can be processed by an external output management product.

Every time a job or a dynamic job completes or terminates on an IBM Z Workload Scheduler Agent, the Output collector started task receives an event from the IBM Z Workload Scheduler controller (which manages all communication with the agents and the dynamic domain managers in the z-centric environment). The event contains the information necessary for Output collector to identify the job and where it run. The output collector then retrieves the job log from the agent, or the dynamic domain manager if the job is dynamic, and copies it to a SYSOUT in JES (using a specific SYSOUT class) to make it available to an output management product.

Activation of this feature is optional. If you activate it, it automatically collects the logs of all jobs run in the z-centric environment, regardless of whether they complete successfully or terminate in error. If you do not activate it, you can still configure your system to either request logs manually or to receive those of jobs ended in error.

The following figure describes the job log retrieval process with Output collector.



Figure 12. Job log retrieval with Output collector.

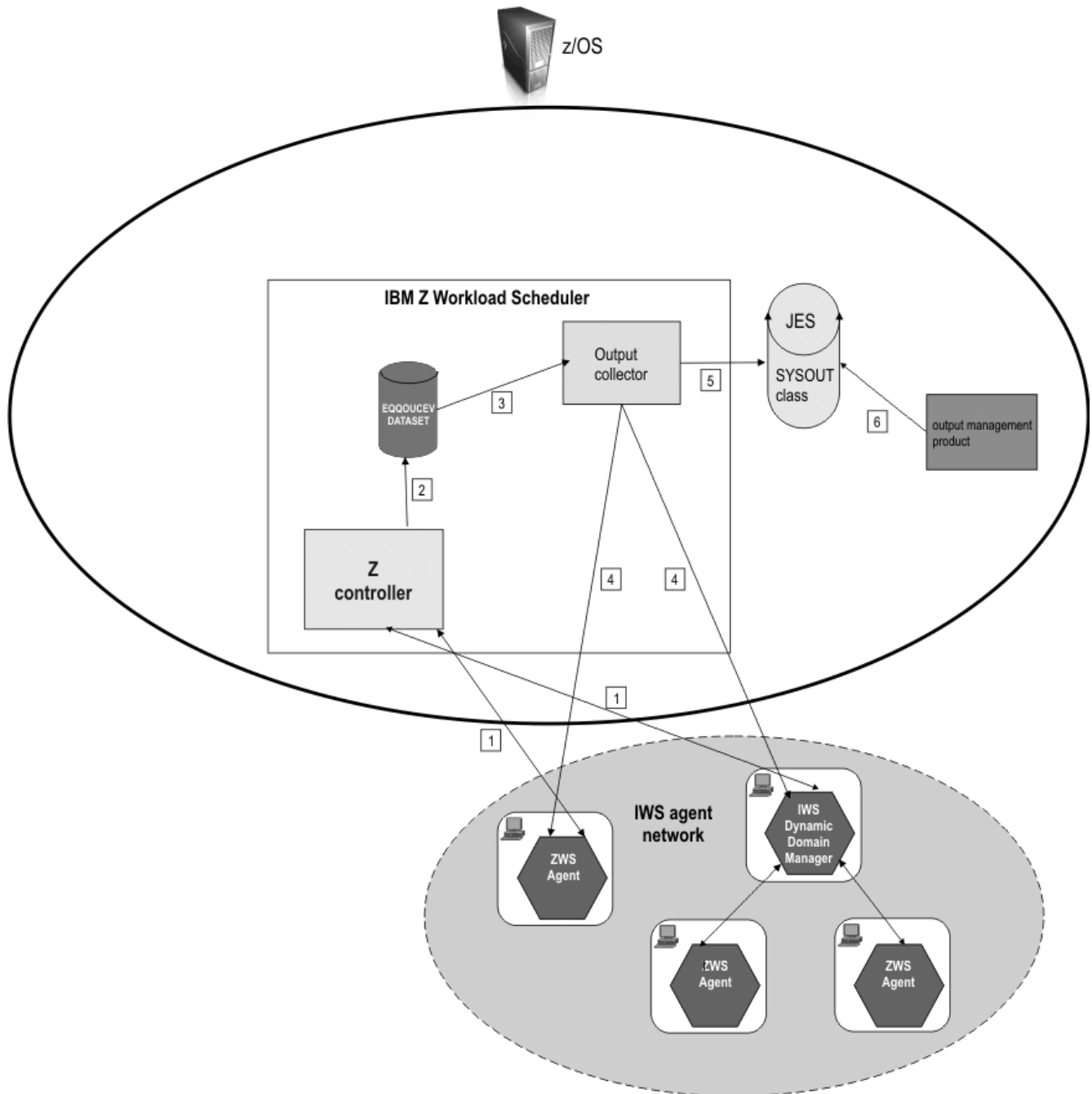

Where:

1. The controller submits and tracks jobs and gets the job logs upon request.
2. Every time a job completes or terminates, the controller writes an event in the EQQOUCV data set. The event contains identification of the job and the name of the agent that ran it.
3. Output collector reads the event in EQQOUCV.
4. Based on the information found in the event record, Output collector retrieves the job log from the agent (or the dynamic domain manager if the job is dynamic).

5. Output collector copies the job log to a SYSOUT in JES using a specific SYSOUT class.
6. The external output management product can get the job log for analysis, accounting, and other operations.

The controller and Output collector use the EQQOUCV and EQQOUCKP data sets to share the information concerning completed or terminated jobs. The communication process is based upon events. Every time a job completes or terminates, the controller queues an event for Output collector with the information necessary to identify the job and the agent that run it in a new record in EQQOUCV. Output collector reads the record, checkpoints it in EQQOUCKP, dispatches it to the proper thread, and marks the event as processed moving to the next-to-read index in the data set header. EQQOUCKP is used to checkpoint the incoming requests to prevent their loss in case of unplanned closures.

To write a job log in the JES spool, Output collector allocates a SYSOUT data set with DDNAME equal to the job name, writes the job log in it, and then closes it. This implies that all the SYSOUTS will have the started task job name and job id and will differ only in the DDNAME and job log header.



**Attention:** The following event may take place while Output collector is processing more job instances with the same name at the same time, even if on different agents: if Output collector is retrieving a particularly sizable log from an agent and the agent goes offline, Output collector stops the retrieval until the link with the agent is established again. As soon as the agent is online again, Output collector resumes retrieving the log. The anomaly is that, if in this lapse of time Output collector is requested to retrieve any other logs with the same name, perhaps from other agents (remember that all logs are named after their jobs), the blocked state is extended also to these requests. As soon as conditions are set for resuming the retrieval of the first log, the other logs are also processed. This does not apply to other job logs having different names: Output collector in this time span continues to process them normally.

## Activating and configuring Output collector

This is a summary about how to activate and configure the Output collector started task.

To activate the Output collector, run the EQQJOBS installation aid and go to panel EQQJOBSC of option `1 - Create sample job JCL`. In the EQQJOBSC panel you specify that Output collector will be running and you enter the names of the SYSOUT class and of the WRITER task that Output collector uses to copy the logs to the JES spool. This creates the sample started task procedure and initial parameters for running Output collector and allocates the data sets (EQQOUCV and EQQOUCKP) used for receiving job log information from the controller. See *IBM Z Workload Scheduler: Planning and Installation* for a detailed description.

To fully configure Output collector, you must act on the following initialization statements in the controller:

### HTTPOPTS

Add the following keywords:

```
OUTPUTCOLLECTOR
```

Specify that the feature will be running.

**JLOGHDRTEMPL**

Specify the name of the EQQPARM library member that contains the job log header. This keyword is not exclusive to the Output collector, but can be used for all the job logs produced in the z-centric environment.

These keywords are independent of the `JOBLOGRETRIEVAL` keyword, which enables users to request job logs manually through the usual IBM® Z Workload Scheduler interfaces.

**ROUTOPTS**

To work with the Output collector task, it is required that at least one IBM Z Workload Scheduler Agent (z-centric) destination is defined in the keyword `HTTP` or `HTTPS`.

**OPCOPTS**

Optionally, add the `OUTCOL` keyword to specify the name of the Output collector started task to the controller. In a sysplex environment this enables the standby controller to continue the interaction with Output collector.

**OUCOPTS**

Add this initialization statement and its keywords to define:

- The names of the JES SYSOUT class and of the WRITER task used by Output collector (if they were not defined with EQQJOBS).
- The name of the EQQPARM library member that contains the OPCOPTS, ROUTOPTS, and HTTPOPTS statements.
- The number of threads (range) that Output collector can open.
- The maximum number of job logs that Output collector can retrieve concurrently from an agent.
- The name of the controller for which Output collector is started.

In a sysplex configuration the Output collector started task must reside in the same image where the controller is.

For a detailed description of the HTTPOPTS, OPCOPTS, and OUCOPTS statements, see *IBM Z Workload Scheduler: Customization and Tuning*.

## Refreshing destinations from Output collector

You can use the MODIFY operator commands to display and refresh HTTP/HTTPS destinations also from Output collector.

You can refresh or display IBM Z Workload Scheduler Agent [destinations on page 39](#) while Output collector is running, without having to stop and restart Output collector to make the changes effective. To do so, run the TSO commands:

- `/F procname, DSPDEST` to display
- `/F procname, RFRDEST` to add, modify, or delete

where in *procname* you can enter the JCL procedure name for Output collector instead of the one for the controller.

If you run `/F procname, RFRDEST` with the *procname* for the controller, the refresh operation is run on the controller and propagated also to Output collector.

Be aware that any changes you make using the procedure name for the controller apply also to Output collector, while they are not extended to the controller if you use the procedure name for Output collector.

# Chapter 13. Troubleshooting

Troubleshooting agent problems

The following problems could be encountered:

## On AIX operating systems the concurrent submission of one hundred or more jobs on the same agent can result in a core dump or in a resource temporarily unavailable message

On AIX operating systems, the concurrent submission of one hundred or more jobs on the same agent can result in a memory dump or in a resource temporarily unavailable message

On AIX operating systems if you submit concurrently one hundred or more jobs on the same agent you can receive a core memory dump or the following message:

```
resource temporarily unavailable
```

### Cause and solution:

This problem is due to insufficient memory and the process number per user allocated to run the jobs concurrently. To solve this problem, verify the value of the following configuration settings and change them as follows:

#### Ulimit settings

The submission of a significant number of Java jobs requires a large amount of memory. Change the value for data, stack, and memory limits according to the number of jobs you want to submit. The submission of a significant number of native jobs requires a high number of file descriptors and processes. Change the values for nofiles and processes according to the number of jobs you want to submit. The following example gives possible setting values to submit 100 jobs concurrently:

```
time(seconds)      unlimited
file(blocks)       2097151
data(kbytes)       131072
stack(kbytes)      32768
memory(kbytes)     32768
coredump(blocks)   2097151
nofiles(descriptors) 4000
threads(per process) unlimited
processes(per user) unlimited
```

#### Process number per user

To submit a high number of jobs concurrently you must have a high value for the **maxuproc** setting. Use the **lsattr -E -l sys0 -a maxuproc** command to verify the number of concurrent processes that a user can create. Use the **chdev -l sys0 -a maxuproc=<value>** command to change the value for the **maxuproc** setting. For example, to submit 100 jobs concurrently use the following command:

```
chdev -l sys0 -a maxuproc=500
```

# Appendix A. Configuring to schedule job types with advanced options

## About this task

In addition to defining job types with advanced options using the Dynamic Workload Console or the [JOBREC on page 74](#) statement, you can use the related configuration files. The options you define in the configuration files apply to all job types with advanced options of the same type. You can override these options when defining the job using the Dynamic Workload Console or the [JOBREC on page 74](#) statement.

Configuration files are available on each dynamic agent in `TWA_home/TWS/JavaExt/cfg` for the following job types with advanced options:

**Table 7. Configuration files for job types with advanced options**

Job type	File name	Keyword
<ul style="list-style-type: none"><li>• Database job type</li><li>• MSSQL Job</li></ul>	DatabaseJobExecutor.properties	<p>Use the <code>jdbDriversPath</code> keyword to specify the path to the JDBC drivers. Define the keyword so that it points to the JDBC jar files directory, for example:</p> <pre>jdbDriversPath=c:\\mydir\\jars\\jdbc</pre> <p>The JDBC jar files must be located in the specified directory or its subdirectories. Ensure you have list permission for the directory and its sub subdirectories.</p> <p> <b>Note:</b> The MSSQL database requires version 4 of the JDBC drivers for both Database and MSSQL Job job types.</p>
Java™	JavaJobExecutor.properties	<p>Use the <code>jarPath</code> keyword to specify the path to the directory where the jar files are stored. This includes all jar files stored in the specified directory and all sub directories.</p>
J2EE	J2EEJobExecutorConfig.properties	<p>For more information about the J2EE job type, see <a href="#">Configuring to schedule J2EE jobs</a>.</p>

## Logging information about job types with advanced options

You can use the `logging.properties` file to configure the logging process for job types with advanced options, with the exception of the Executable and Access Method job types.

The `logging.properties` file is located on the IBM Z Workload Scheduler Agent, under `TWA_home/TWS/JavaExt/cfg/logging.properties`.

Following installation, this file is as follows:

```
# Specify the handlers to create in the root logger
# (all loggers are children of the root logger)
# The following creates two handlers
handlers = java.util.logging.ConsoleHandler, java.util.logging.FileHandler

# Set the default logging level for the root logger
.level = INFO

# Set the default logging level for new ConsoleHandler instances
java.util.logging.ConsoleHandler.level = INFO

# Set the default logging level for new FileHandler instances
java.util.logging.FileHandler.level
    = ALL
java.util.logging.FileHandler.pattern
    = C:\TWA_home\TWS\JavaExt\logs\javaExecutor%g.log
java.util.logging.FileHandler.limit
    = 1000000
java.util.logging.FileHandler.count
    = 10

# Set the default formatter for new ConsoleHandler instances
java.util.logging.ConsoleHandler.formatter = java.util.logging.
SimpleFormatter
java.util.logging.FileHandler.formatter = java.util.logging.
SimpleFormatter

# Set the default logging level for the logger named com.mycompany
com.ibm.scheduling = INFO
```

You can customize:

- The logging level (from INFO to WARNING, ERROR, or ALL) in the following keywords:

```
.level
```

Defines the logging level for the internal logger.

```
com.ibm.scheduling
```

Defines the logging level for the job types with advanced options. To log information about job types with advanced options, set this keyword to ALL.

- The path where the logs are written, specified by the following keyword:

```
java.util.logging.FileHandler.pattern
```

## Appendix B. Managing return codes

By default, all nonzero error codes are considered as an error. Optionally, you can define the error codes that, for job-tracking purposes, are not considered as errors. To do this, set the following parameters:

### NOERROR

Defines a list of error codes that, for job-tracking purposes, are treated as normal completion codes. When setting this value on an IBM Z Workload Scheduler Agent, beware that the maximum length allowed for a return code is 4 digits. If the IBM Z Workload Scheduler Agent returns an error code higher than 9999, it is truncated at the fourth rightmost digit. For example, 12345 is considered as 2345.

For negative error codes, specify a five-character sequence starting with the minus (-) symbol, for example -0008.

### ERRRES

Defines a list of error codes that, for job-tracking purposes, result in an automatic reset of an operation. The operation is reset to status A (arriving) and contains the message Error, automatically reset in its operation details panel. An error code can be either of the following:

- 4-digit job or started-task return code (*nnnn*)
- System abend code (*Sxxx*)
- User abend code (*Uxxx*)
- IBM Z Workload Scheduler-defined code

The HIGHRC parameter is supported for positive RC on IBM Z Workload Scheduler Agents and agents. Jobs ending with negative RC are always considered in error. The negative RC are handled through NOERROR. For a detailed description of NOERROR and ERRRES, see *IBM Z Workload Scheduler: Customization and Tuning*.

The following is a list of the return codes for each job type with advanced options:

#### Database jobs:

```
RC = 0 -> Job completed successfully
RC = -1 -> SQL statement was run with an exit code different from 1
RC = -2 -> MSSQL Job error
RC = -3 -> SQL statement did not run because of an error in the statement
```

#### File transfer jobs:

```
RC = 0 -> The file transfer completed successfully

RC = -1 -> The file transfer is not performed. The job fails with the following
error code: AWKFTE007E
```

Explanation: An error occurred during the file transfer operation

Possible reasons: Remote file not found or permission denied

```
RC = -2 -> The file transfer is not performed. The job fails with the following
error code: AWKFTE020E
```

Explanation: Only for SSH or Windows protocols. An error was returned



while attempting to convert the code page

Possible reasons: For SSH or Windows protocols, the code page is automatically detected and converted. In this case, there is an error in the code page of the file to be transferred, which is not compliant with the code page of the local system

RC = -3 -> The file transfer is not performed. The job fails with the following error code: AWKFTE015E

Explanation: An error occurred during the file transfer operation

Possible reasons: Local file is not found

RC = -4 -> The file transfer is performed with the default code page. The job fails with the following error code: AWKFTE023E

Explanation: The specified codepage conversion has not been performed. File transfer has been performed with default code pages

Possible reasons: The specified code page is not available

IBM i jobs:

Return code = user return code when retrieved

Return code = 0 -> job completed successfully

Return code > -1 -> job completed unsuccessfully

Web services jobs:

RC = 0 -> Job completed successfully

RC = -1 -> The server hostname contained in the Web Service URL is unknown

RC = -2 -> Web Service invocation error

# Appendix C. Modifying the workstation from fault-tolerant agent to z-centric agent

## About this task

The fault-tolerant agent workstations are no longer supported and must be modify to IBM Z Workload Scheduler Agent (z-centric) workstations, as described in the following procedure.



### Note:

- For jobs whose [JOBREC on page 74](#) includes an RCONDSUC parameter, see [Managing return codes on page 160](#) for information about how to perform return code management for jobs scheduled on an IBM Z Workload Scheduler Agent.
- To modify a fault-tolerant agent workstation that uses non-centralized job scripts to an IBM Z Workload Scheduler Agent workstation, you can follow the same procedure. Additionally, you must convert the information contained in the EQQSCLIB data set into information for the JOBLIB data set, by using the appropriate [JOBREC on page 74](#) statement keywords.

On the Z controller:

1. Define the IBM Z Workload Scheduler Agent destination by setting the ROUTOPTS statement. For details, refer to [Defining destinations with the ROUTOPTS statement on page 39](#).
2. Optionally, customize the HTTP connection with the HTTPOPTS statement. For details, refer to [Customizing the HTTP connection with the HTTPOPTS statement on page 41](#).
3. From the MODIFYING GENERAL INFORMATION ABOUT A WORK STATION panel, modify the workstation database definition by setting Z-CENTRIC AGENT to . For details, refer to [Modifying on page 55](#).
4. To modify one fault-tolerant agent at a time, comment out the CPUREC statement related to the fault-tolerant workstation you are modifying.

To modify all the fault-tolerant agents at once, delete the TPLGYPRM parameter in the BATCHOPT statement.

5. For your changes to be effective, run a DAILY PLAN batch job.

## Results

Message EQQ0371I is issued in EQQMLOG:

```
Z-CENTRIC AGENT INFO HAS BEEN CHANGED FOR WORKSTATION WSNAME
```

If on the workstation modified there were operations with status S (started), the status is changed to I (interrupted) and message EQQ0372W is issued in EQQMLOG:

```
STATUS OF OPERATION ADID IA OPNO HAS BEEN CHANGED FROM STARTED TO INTERRUPTED  
AS A CONSEQUENCE OF WORKSTATION WSNAME CHANGE
```

The DP batch job ends with RC=4.

After you have modified all the fault-tolerant agents to z-centric agents:

1. Delete any statements related to the end-to-end with fault tolerance environment from the Z controller and server.
2. From the Z controller started task, delete the following DD names:
  - EQQTWSIN
  - EQQTWSOU
  - EQQSCLIB
  - EQQTWSCS
3. From the server started task, delete the following DD names:
  - EQQTWSIN
  - EQQTWSOU
  - EQQTWSCS

# Appendix D. Defining access methods for agents

Access methods are used to extend the job scheduling functions of IBM Workload Scheduler to other systems and applications. They run on:

## **Extended agents (applies only to IBM Workload Scheduler)**

They are logical workstations related to an access method hosted by a physical IBM Workload Scheduler workstation (not another extended agent). More than one extended agent workstation can be hosted by the same IBM Workload Scheduler workstation and use the same access method. The extended agent runs on fault-tolerant agents defined using a standard IBM Workload Scheduler workstation definition, which gives the extended agent a name and identifies the access method. The access method is a program that is run by the hosting workstation whenever IBM Workload Scheduler submits a job to an external system.

Jobs are defined for an extended agent in the same manner as for other IBM Workload Scheduler workstations, except that job attributes are dictated by the external system or application.

Information about job running execution is sent to IBM Workload Scheduler from an extended agent using the job `stdlist` file. A method options file can specify alternate logins to launch jobs and check `opens` file dependencies. For more information, see the *User's Guide and Reference*.

A physical workstation can host a maximum of 255 extended agents.

## **dynamic agents and IBM Z Workload Scheduler agents (z-centric)**

They communicate with external systems to start the job and return the status of the job. To run access methods on external applications using dynamic agents, you define a job of type **access method**.

Access methods are available on the following systems and applications.

- SAP
- z/OS
- Custom methods
- unixssh
- unixrsh

The UNIX™ access methods included with IBM Workload Scheduler, are described in the related section in *Administration Guide*.

If you are working with dynamic agents, for information about defining IBM Workload Scheduler workstations, see the section that explains how to define workstations in the database in *User's Guide and Reference*. For information about writing access methods, see the section about the access method interface in *User's Guide and Reference*.

More information about access methods is found in *Scheduling Job Integrations with IBM Workload Automation*.

## Access method interface

The interface between IBM Workload Scheduler and an access method consists of information passed to the method on the command line, and of messages returned to IBM Workload Scheduler in **stdout**.

### Method command line syntax

The IBM Workload Scheduler host runs an access method using the following command line syntax:

```
methodname -t task options -- taskstring
```

where:

#### ***methodname***

Specifies the file name of the access method. All access methods must be stored in the directory:

```
TWS_home/methods
```

#### ***-t task***

Specifies the task to be performed, where *task* is one of the following:

##### **LJ**

Launches a job.

##### **MJ**

Manages a previously launched job. Use this option to resynchronize if a prior **LJ** task ended unexpectedly.

##### **CF**

Extended agents only. Checks the availability of a file. Use this option to check file `opens` dependencies.

##### **GS**

Extended agents only. Gets the status of a job. Use this option to check job `follows` dependencies.

#### ***options***

Specifies the options associated with the task. See [Task options on page 165](#) for more information.

#### ***taskstring***

A string of up to 255 characters associated with the task. See [Task options on page 165](#).

## Task options

The task options are listed in [Table 8: Method command task options on page 166](#). An X means that the option is valid for the task.

**Table 8. Method command task options**

Task	-c	-n	-p	-r	-s	-d	-l	-o	-j	-q	-w	-S	Task String
LJ	X	X	X	X	X	X	X	X	X			X	<i>ljstring</i>
MJ	X	X	X	X	X	X	X	X	X				<i>mjstring</i>
CF	X	X	X							X			<i>cfstring</i>
GS	X	X	X	X		X					X		<i>gsstring</i>

**-c *xagent,host,master***

Specifies the names of the agent, the host, and the master domain manager separated by commas.

**-n *nodename***

Specifies the node name of the computer associated with the agent, if any. This is defined in the extended agent's workstation definition **Node** field.

**-p *portnumber***

Specifies the TCP/IP port number associated with the agent, if any. This is defined in the agent workstation definition **TCP Address** field.

**-r *currentrun,specificrun***

Specifies the current run number of IBM Workload Scheduler and the specific run number associated with the job separated by a comma. The current and specific run numbers might be different if the job was carried forward from an earlier run.

**-s *jstream***

Specifies the name of the job's job stream.

**-d *scheddate,epoch***

Specifies the job stream date (*yymmdd*) and the epoch equivalent, separated by a comma.

**-l *user***

Specifies the job's user name. This is defined in the job definition **Logon** field.

**-o *stdlist***

Specifies the full path name of the job's standard list file. Any output from the job must be written to this file.

**-j *jobname,id***

Specifies the job's name and the unique identifier assigned by IBM Workload Scheduler, separated by a comma. The name is defined in the job definition **Job Name** field.

**-q *qualifier***

Specifies the qualifier to be used in a test command issued by the method against the file.

**-w timeout**

Specifies the amount of time, in seconds, that IBM Workload Scheduler waits to get a reply on an external job before sending a SIGTERM signal to the access method. The default is 300.

**-S new name**

Specifies that the job is rerun using this name in place of the original job name. Within a job script, you can use the `jobinfo` command to return the job name and run the script differently for each iteration.

**-- ljstring**

Used with the **LJ** task. The string from the **Script File** or **Command** field of the job definition.

**-- mjstring**

Used with the **MJ** task. The information provided to the IBM Workload Scheduler by the method in a message indicating a job state change **%CJ** (for additional details on messages indicating job state change, see [Method response messages on page 167](#)) following to an **LJ** task. Usually, this identifies the job that was launched. For example, a UNIX® method can provide the process identification (PID) of the job it launched, which is then sent by the IBM Workload Scheduler as part of an **MJ** task.

**-- cfstring**

Used with the **CF** task. For a file `opens` dependency, the string from the **Opens Files** field of the job stream definition.

**-- gsstring**

Used with the **GS** task. Specifies the job whose status is checked. The format is as follows:

`followsjob[,jobid]`

where:

**followsjob**

The string from the **Follows Sched/Job** list of the job stream definition.

**jobid**

An optional job identifier received by IBM Workload Scheduler in a **%CJ** response to a previous **GS** task.

## Method response messages

Methods return information to IBM Workload Scheduler in messages written to **stdout**. Each line starting with a percent sign (%) and ending with a new line is interpreted as a message. The messages have the following format:

**%CJ** *state* [*mjstring* | *jobid*]

**%JS** [*cputime*]

**%RC** *rc*

**%UT** [*errormessage*]

where:

**CJ**

Changes the job state.

**state**

The state to which the job is changed. All IBM Workload Scheduler job states are valid except HOLD and READY. For the **GS** task, the following states are also valid:

**ERROR**

An error occurred.

**EXTRN**

Status is unknown.

**mjstring**

A string of up to 255 characters that IBM Workload Scheduler will include in any **MJ** task associated with the job.

**jobid**

A string of up to 64 characters that IBM Workload Scheduler will include in any **GS** task associated with the job.

**JS [cputime]**

Indicates successful completion of a job and provides its elapsed run time in seconds.

**RC rc**

*rc* is a number that is interpreted by IBM Workload Scheduler as the return code of the extended agent job. The return code is taken into account only if a return code condition was specified in the definition of the extended agent job. Otherwise, it is ignored and the successful completion of the extended agent job is indicated by the presence of message **%JS [cputime]**. Likewise, if the method does not send the **%RC** message, then the successful completion of the extended agent job is indicated by the presence of message **%JS [cputime]**.

**UT [errormessage]**

Indicates that the requested task is not supported by the method. Displays a string of up to 255 characters that IBM Workload Scheduler will include in its error message.

## Method options file

For extended, agents, and IBM Z Workload Scheduler Agent you can use a method options file to specify login information and other options.

An options file is a text file located in the methods directory of the IBM Workload Scheduler installation, containing a set of options to customize the behavior of the access method. The options must be written one per line and have the following format (with no spaces included):

```
option=value
```



All access methods use two types of options files:

### Extended agents

#### Global options file

A common configuration file created by default for each access method installed, whose settings apply to all the extended agent workstations defined for that method. When the global options file is created, it contains only the **LJuser** option, which represents the operating system user ID used to launch the access method. You can customize the global options file by adding the options appropriate to the access method.

#### Local options file

A configuration file that is specific to each extended agent workstation within a particular installation of an access method. The name of this file is `XANAME_accessmethod.opts`, where:

##### ***XANAME***

Is the name of the extended agent workstation. The value for *XANAME* must be written in uppercase alphanumeric characters. Double-byte character set (DBCS), Single-byte character set (SBCS), and Bidirectional text are not supported.

##### ***accessmethod***

Is the name of the access method.

If you do not create a local options file, the global options file is used. Every extended agent workstation, except for z/OS, must have a local options file with its own configuration options.

For example, if the installation of the access method includes two extended agent workstations, `CPU1` and `CPU2`, the names of the local options files are respectively `CPU1_accessmethod.opts` and `CPU2_accessmethod.opts`.

IBM Workload Scheduler reads the options file, if it exists, before running an access method. For extended agents, if the options file is modified after IBM Workload Scheduler is started, the changes take effect only when it is stopped and restarted.

### IBM Z Workload Scheduler Agents and agents

#### Global options file

A common configuration file created by default for each access method installed, whose settings apply to all the agent workstations defined for that method. When the global options file is created, it contains only the **LJuser** option, which represents the operating system user ID used to run the access method. You can customize the global options file by adding the options appropriate to the access method.

The name of the global options file is `accessmethod.opts`, where `accessmethod` is the name of the method you are creating.

### Local options file

A configuration file that is specific to each access method. The name of this file is

`optionsfile_accessmethod.opts`,

#### In a distributed environment:

- If you are defining a job to run the access method by using the Dynamic Workload Console it is the options file you specified in the **Create new > Job definition > ERP > Access Method XA** Task tab.
- If you are defining the access method by using **composer** it is the options file you specified in the **target** attribute of the job definition.

If you do not create a local options file, the global options file is used.

#### In a z/OS environment:

- If you are defining a job to run the access method by using the Dynamic Workload Console it is the options file you specified in the **Create new > ERP > Access Method XA** Task tab.
- If you are defining the access method by using the **JOBREC** statement it is the name of the workstation where the access method runs.

If you do not create a local options file, the global options file is used.

If you do not specify an option in the `options_file_accessmethod.opts` file the product uses the value specified for that option in the global option file. If you do not specify them neither in the `options_file_accessmethod.opts` file nor in the global option file the product issues an error message.

The options file must have the same path name as its access method, with an `.opts` file extension. For example, the Windows® path name of an options file for a method named `netmeth` is

```
TWS_home\methods\netmeth.opts
```

IBM Workload Scheduler reads the options file, if it exists, before running an access method.

The options recognized by IBM Workload Scheduler are as follows:

#### **LJuser=username**

Specifies the login to use for the **LJ** and **MJ** tasks. The default is the login from the job definition. See [Launch job task \(LJ\) on page 171](#) and [Manage job task \(MJ\) on page 172](#).

#### **CFuser=username**

Extended agents only. Specifies the login to use for the **CF** task. The default for UNIX® is **root**, and for Windows® is the user name of the account in which the product was installed. See the topic about check file tasks (CF) extended agents in the *IBM Workload Scheduler: User's Guide and Reference*.

**GSuser=*username***

Specifies the login to use for the **GS** tasks. The default for UNIX® is **root**, and for Windows® is the user name of the account with which IBM Workload Scheduler was installed. See Get status task (GS) extended agents only.

**GStimeout=*seconds***

Specifies the amount of time, in seconds, IBM Workload Scheduler waits for a response before killing the access method. The default is **300** seconds.

**nodename=*node\_name***

Specifies the host name or IP address if required by the method you are defining. For the **unixssh** access method, the host name or IP address to connect to the remote engine.

**PortNumber=*port\_number***

Specifies the port number if required by the method you are defining. For the **unixssh** access method, the port to connect to the remote engine.

For IBM Z Workload Scheduler Agents and agents, you can specify the node name and port number also in the `JobManager.ini` file.

If you do not specify them in the `options_file_accessmethod.opts` file the product uses the value specified in the global option file. If you do not specify them neither in the `options_file_accessmethod.opts` file nor in the global option file the product uses the value specified in the `option_file` stanza of the `JobManager.ini` file.



**Note:** If the extended agent host is a Windows® computer, these users must be defined as IBM Workload Scheduler user objects.

## Running methods

The following subsections describe the interchange between IBM Workload Scheduler and an access method.

### Launch job task (LJ)

#### About this task

The **LJ** task instructs the extended agent method to launch a job on an external system or application. Before running the method, IBM Workload Scheduler establishes a run environment. The **LJuser** parameter is read from the method options file to determine the user account with which to run the method. If the parameter is not present or the options file does not exist, the user account specified in the **Logon** field of the job's definition is used. In addition, the following environment variables are set:

**HOME**

The login user's home directory.

**LOGNAME**

The login user's name.

**PATH**

For UNIX®, it is set to `/bin:/usr/bin`. For Windows®, it is set to `%SYSTEM%\SYSTEM32`.

**TWS\_PROMOTED\_JOB**

Set to `YES`, when the job (a mission-critical job or one of its predecessors) is promoted.

**TZ**

The time zone.

If the method cannot be run, the job is placed in the FAIL state.

Once a method is running, it writes messages to its **stdout** that indicate the state of the job on the external system. The messages are summarized in [Table 9: Launch job task \(LJ\) messages on page 172](#).

**Table 9. Launch job task (LJ) messages**

Task	Method Response	IBM Workload Scheduler Action
<b>LJ</b> and <b>MJ</b>	<b>%CJ</b> <i>state</i> [ <i>mjstring</i> ]	Sets job state to <i>state</i> . Includes <i>mjstring</i> in any subsequent <b>MJ</b> task.
	<b>%JS</b> [ <i>cputime</i> ]	Sets job state to SUCC.
	Exit code=non-zero	Sets job state to ABEND.
	<b>%UT</b> [ <i>errormessage</i> ] and Exit code=2	Sets job state to ABEND and displays <i>errormessage</i> .

A typical sequence consists of one or more **%CJ** messages indicating changes to the job state and then a **%JS** message before the method exits to indicate that the job ended successfully. If the job is unsuccessful, the method must exit without writing the **%JS** message. A method that does not support the **LJ** task, writes a **%UT** message to **stdout** and exits with an exit code of 2.

## Manage job task (MJ)

### About this task

The **MJ** task is used to synchronize with a previously launched job if IBM Workload Scheduler determines that the **LJ** task ended unexpectedly. IBM Workload Scheduler sets up the environment in the same manner as for the **LJ** task and passes it the *mjstring*. See [Launch job task \(LJ\) on page 171](#) for more information.

If the method locates the specified job, it responds with the same messages as an **LJ** task. If the method is unable to locate the job, it exits with a nonzero exit code, causing IBM Workload Scheduler to place the job in the ABEND state.

## Killing a job

### About this task

While an **LJ** or **MJ** task is running, the method must trap a SIGTERM signal (signal **15**). The signal is sent when an operator issues a **kill** command from IBM Workload Scheduler console manager. Upon receiving the signal, the method must attempt to stop (**kill**) the job and then exit without writing a **%JS** message.

## Appendix E. Collecting job metrics

You can run the following SQL queries on the Workload Scheduler database to retrieve the number of jobs run by IBM Workload Scheduler over a period of time. One query determines the number of jobs run by specific workstations, while the other query determines the number of jobs run on the entire IBM Workload Scheduler domain.

You can run the queries from the command line interface of your database or you can add them in the Dynamic Workload Console to create your custom SQL report.

### Job metrics queries for DB2 for zOS

Use the following SQL query to find the number of jobs run on specific workstations:

```
SELECT year(job_run_date_time) AS Year, month(job_run_date_time) AS Month,
cast (count(job_run_date_time) AS INT) AS JobNbr FROM mdl.job_history_v
WHERE workstation_name IN ('WKS_1', 'WKS_2', 'WKS_N')
GROUP BY year(job_run_date_time), month(job_run_date_time)
```

where 'WKS\_1', 'WKS\_2', 'WKS\_N' are the names of the workstations that ran the jobs you want counted.

Use the following SQL query to find the number of jobs run on the entire IBM Workload Scheduler domain:

```
SELECT year(job_run_date_time) AS Year, month(job_run_date_time) AS Month,
cast (count(job_run_date_time) AS INT) AS JobNbr FROM mdl.job_history_v
GROUP BY year(job_run_date_time), month(job_run_date_time)
```

### Job metrics queries for DB2

Use the following SQL query to find the number of jobs run on specific workstations:

```
SELECT year(job_run_date_time) AS Year, month(job_run_date_time) AS Month,
cast (count(job_run_date_time) AS INT) AS JobNbr FROM mdl.job_history_v
WHERE workstation_name IN ('WKS_1', 'WKS_2', 'WKS_N')or
(workstation_name = '-' and JOB_STREAM_WKS_NAME_IN_RUN in('WKS_1', 'WKS_2', 'WKS_N') )
GROUP BY year(job_run_date_time), month(job_run_date_time)
```

where 'WKS\_1', 'WKS\_2', 'WKS\_N' are the names of the workstations that ran the jobs you want counted.

Use the following SQL query to find the number of jobs run on the entire IBM Workload Scheduler domain:

```
SELECT year(job_run_date_time) AS Year, month(job_run_date_time) AS Month,
cast (count(job_run_date_time) AS INT) AS JobNbr FROM mdl.job_history_v
GROUP BY year(job_run_date_time), month(job_run_date_time)
```

# Notices

This document provides information about copyright, trademarks, terms and conditions for product documentation.

© Copyright IBM Corporation 1993, 2016 / © Copyright HCL Technologies Limited 2016, 2024

This information was developed for products and services offered in the US. This material might be available from IBM in other languages. However, you may be required to own a copy of the product or product version in that language in order to access it.

IBM may not offer the products, services, or features discussed in this document in other countries. Consult your local IBM representative for information on the products and services currently available in your area. Any reference to an IBM product, program, or service is not intended to state or imply that only that IBM product, program, or service may be used. Any functionally equivalent product, program, or service that does not infringe any IBM intellectual property right may be used instead. However, it is the user's responsibility to evaluate and verify the operation of any non-IBM product, program, or service.

IBM may have patents or pending patent applications covering subject matter described in this document. The furnishing of this document does not grant you any license to these patents. You can send license inquiries, in writing, to:

*IBM Director of Licensing*  
*IBM Corporation*  
*North Castle Drive, MD-NC119*  
*Armonk, NY 10504-1785*  
*US*

For license inquiries regarding double-byte character set (DBCS) information, contact the IBM Intellectual Property Department in your country or send inquiries, in writing, to:

*Intellectual Property Licensing*  
*Legal and Intellectual Property Law*  
*IBM Japan Ltd.*  
*19-21, Nihonbashi-Hakozakicho, Chuo-ku*  
*Tokyo 103-8510, Japan*

INTERNATIONAL BUSINESS MACHINES CORPORATION PROVIDES THIS PUBLICATION "AS IS" WITHOUT WARRANTY OF ANY KIND, EITHER EXPRESS OR IMPLIED, INCLUDING, BUT NOT LIMITED TO, THE IMPLIED WARRANTIES OF NON-INFRINGEMENT, MERCHANTABILITY OR FITNESS FOR A PARTICULAR PURPOSE. Some jurisdictions do not allow disclaimer of express or implied warranties in certain transactions, therefore, this statement may not apply to you.

This information could include technical inaccuracies or typographical errors. Changes are periodically made to the information herein; these changes will be incorporated in new editions of the publication. IBM may make improvements and/or changes in the product(s) and/or the program(s) described in this publication at any time without notice.

Any references in this information to non-IBM websites are provided for convenience only and do not in any manner serve as an endorsement of those websites. The materials at those websites are not part of the materials for this IBM product and use of those websites is at your own risk.

IBM may use or distribute any of the information you provide in any way it believes appropriate without incurring any obligation to you.

Licensees of this program who wish to have information about it for the purpose of enabling: (i) the exchange of information between independently created programs and other programs (including this one) and (ii) the mutual use of the information which has been exchanged, should contact:

*IBM Director of Licensing*

*IBM Corporation*

*North Castle Drive, MD-NC119*

*Armonk, NY 10504-1785*

*US*

Such information may be available, subject to appropriate terms and conditions, including in some cases, payment of a fee.

The licensed program described in this document and all licensed material available for it are provided by IBM under terms of the IBM Customer Agreement, IBM International Program License Agreement or any equivalent agreement between us.

The performance data discussed herein is presented as derived under specific operating conditions. Actual results may vary.

Information concerning non-IBM products was obtained from the suppliers of those products, their published announcements or other publicly available sources. IBM has not tested those products and cannot confirm the accuracy of performance, compatibility or any other claims related to non-IBM products. Questions on the capabilities of non-IBM products should be addressed to the suppliers of those products.

This information is for planning purposes only. The information herein is subject to change before the products described become available.

This information contains examples of data and reports used in daily business operations. To illustrate them as completely as possible, the examples include the names of individuals, companies, brands, and products. All of these names are fictitious and any similarity to actual people or business enterprises is entirely coincidental.

#### COPYRIGHT LICENSE:

This information contains sample application programs in source language, which illustrate programming techniques on various operating platforms. You may copy, modify, and distribute these sample programs in any form without payment to IBM, for the purposes of developing, using, marketing or distributing application programs conforming to the application programming interface for the operating platform for which the sample programs are written. These examples have not been thoroughly tested under all conditions. IBM, therefore, cannot guarantee or imply reliability, serviceability, or function of these programs. The sample programs are provided "AS IS", without warranty of any kind. IBM shall not be liable for any damages arising out of your use of the sample programs.



© (HCL Technologies Limited) (2024).

Portions of this code are derived from IBM Corp. Sample Programs.

© Copyright IBM Corp. 2016

## Trademarks

IBM, the IBM logo, and [ibm.com](http://ibm.com) are trademarks or registered trademarks of International Business Machines Corp., registered in many jurisdictions worldwide. Other product and service names might be trademarks of IBM® or other companies. A current list of IBM® trademarks is available on the web at "Copyright and trademark information" at [www.ibm.com/legal/copytrade.shtml](http://www.ibm.com/legal/copytrade.shtml).

Adobe™, the Adobe™ logo, PostScript™, and the PostScript™ logo are either registered trademarks or trademarks of Adobe™ Systems Incorporated in the United States, and/or other countries.

IT Infrastructure Library™ is a Registered Trade Mark of AXELOS Limited.

Linear Tape-Open™, LTO™, the LTO™ Logo, Ultrium™, and the Ultrium™ logo are trademarks of HP, IBM® Corp. and Quantum in the U.S. and other countries.

Intel™, Intel™ logo, Intel Inside™, Intel Inside™ logo, Intel Centrino™, Intel Centrino™ logo, Celeron™, Intel Xeon™, Intel SpeedStep™, Itanium™, and Pentium™ are trademarks or registered trademarks of Intel™ Corporation or its subsidiaries in the United States and other countries.

Linux™ is a registered trademark of Linus Torvalds in the United States, other countries, or both.

Microsoft™, Windows™, Windows NT™, and the Windows™ logo are trademarks of Microsoft™ Corporation in the United States, other countries, or both.



Java™ and all Java-based trademarks and logos are trademarks or registered trademarks of Oracle and/or its affiliates.

Cell Broadband Engine™ is a trademark of Sony Computer Entertainment, Inc. in the United States, other countries, or both and is used under license therefrom.

ITIL™ is a Registered Trade Mark of AXELOS Limited.

UNIX™ is a registered trademark of The Open Group in the United States and other countries.

## Terms and conditions for product documentation

Permissions for the use of these publications are granted subject to the following terms and conditions.

## **Applicability**

These terms and conditions are in addition to any terms of use for the IBM website.

## **Personal use**

You may reproduce these publications for your personal, noncommercial use provided that all proprietary notices are preserved. You may not distribute, display or make derivative work of these publications, or any portion thereof, without the express consent of IBM.

## **Commercial use**

You may reproduce, distribute and display these publications solely within your enterprise provided that all proprietary notices are preserved. You may not make derivative works of these publications, or reproduce, distribute or display these publications or any portion thereof outside your enterprise, without the express consent of IBM.

## **Rights**

Except as expressly granted in this permission, no other permissions, licenses or rights are granted, either express or implied, to the publications or any information, data, software or other intellectual property contained therein.

IBM reserves the right to withdraw the permissions granted herein whenever, in its discretion, the use of the publications is detrimental to its interest or, as determined by IBM, the above instructions are not being properly followed.

You may not download, export or re-export this information except in full compliance with all applicable laws and regulations, including all United States export laws and regulations.

IBM MAKES NO GUARANTEE ABOUT THE CONTENT OF THESE PUBLICATIONS. THE PUBLICATIONS ARE PROVIDED "AS-IS" AND WITHOUT WARRANTY OF ANY KIND, EITHER EXPRESSED OR IMPLIED, INCLUDING BUT NOT LIMITED TO IMPLIED WARRANTIES OF MERCHANTABILITY, NON-INFRINGEMENT, AND FITNESS FOR A PARTICULAR PURPOSE.

# Index

## A

- access method 165
  - agent
    - syntax 165
  - dynamic agent
    - option file 168
  - extended agent
    - option file 168
  - IBM Z Workload Scheduler Agent
    - option file 168
  - interface 165
  - task options 165
- access method for dynamic agent
  - overview 164
- access method for extended agent
  - overview 164
- access method jobs 73
- accessibility viii
- Administering agents on AS/400 115
- Administering agents on i5/OS 115
- Administering agents on IBM i 115, 115
- Administering IBMi agents 115
- Administering IBMi jobs 115
- Administering jobs on AS/400 115
- Administering jobs on i5/OS 115
- advanced job types 62, 64
- agent
  - access method
    - syntax 165
- agent configuration
  - JobManager.ini file 18
  - maintenance 37
- agent log and trace files
  - twstrace syntax 25, 127
- agent logs encoding 22, 123
- agent logs setting 22, 123
- agent problems 157
- agent traces
  - modifying 25, 126
  - viewing settings 25, 126
- agent working directory
  - JobManager.ini file 18
- APARs
  - IJ30805 70
  - PI54546 viii
  - PK00789 46
  - PK40356 46
- APPENDTEXT, keyword of JOBREC for file transfer job types 86
- AROPTS initialization statement
  - ENDTIME keyword 146
  - STARTTIME keyword 146
- AUTHALIAS, keyword of JOBREC 96

## B

- broker jobs promotion 112
- broker promotion variables 112
- broker workstation
  - defining 63
- broker workstations
  - creating 66
  - defining 66
  - jobs by reference 66
  - options 66

## C

- call to a web service

- sample JSDL files 17, 73
- child job on i5/OS 116
- child job on IBM i 116
- child job settings on AS/400 for performances 116
- child job settings on i5/OS for performance 116
- child job settings on IBM i for performances 116
- child jobs settings for performances on AS/400 116
- CLASSNAME, keyword of JOBREC 93
- Cloud & Smarter Infrastructure technical training viii
- CMDTYPE statements
  - JOBREC
    - CMDTYPE keyword 77, 81
- CMDTYPE, keyword of JOBREC 77, 81
- code page
  - view 61
- commands
  - filemonitor 106
  - filewatch 102
- configuring proxy 21
- connection SSL
  - Z controller and IBM i agents 139
  - Z controller
    - and IBM Z Workload Scheduler Agents 70
- connections
  - HTTP 41
- CONNFACTORY, keyword of JOBREC 97, 97
- creating and managing variables and passwords locally 51
- creating and managing variables and passwords locally on the agents 48
- critical dynamic job promotion 112
- crucial dynamic jobs 112

## D

- database
  - collecting job metrics 174
  - database data extract 17, 73
  - database data validation 17, 73
  - database executor 75
  - database job 75
    - configuring 138, 158
  - database operations
    - sample JSDL files 17, 73
  - database stored procedure
    - database jobs
      - sample JSDL files 17, 73
      - sample JSDL files 17, 73
- DB2
  - collecting job metrics 174
  - DB2 database job type
    - detailed syntax diagram 77
  - DB2 for zOS
    - collecting job metrics 174
- DBNAME, keyword of JOBREC 78, 81
- DBTYPE, keyword of JOBREC 78, 81
- defining
  - broker workstation 63
  - destinations 39
  - dynamic pools 65
  - file dependencies 102
  - pools 65

- z-centric workstation 54
- DELETEAFTERDOWNLOAD, keyword of JOBREC for file transfer job types 86
- DELETEAFTERUPLOAD, keyword of JOBREC for file transfer job types 86
- destinations
  - defining 39
  - displaying in MLOG 39
  - listing in MLOG 39
  - modifying 39
  - refreshing 39
  - view 61
- detailed syntax diagram
  - DB2 database job type 77
  - download job type 84
  - executable job type 98
  - file transfer job type 84
  - J2EE jms job type 96
  - Java job type 92
  - MSSQL database job type 80
  - native job type 98
  - Oracle database job type 77
  - script job type 98
  - upload job type 84
  - web service job type 90
  - xajob job type 94
- download job type
  - detailed syntax diagram 84
- dynamic agent
  - access method
    - option file 168
  - overview 164
- dynamic domain manager
  - destinations 39
  - modifying destinations 39
- dynamic domain managers
  - defining destinations 39
  - heartbeat checking interval 39
- dynamic job promotion 112
- dynamic pools
  - defining 65
- dynamic scheduling
  - job types with advanced options 17
- Dynamic Workload Console
  - accessibility viii
- Dynamic Workload Console global settings
  - 41

## E

- education viii
- end-to-end with z-centric capabilities
  - overview 13
  - steps to set up environment 13
- ENDTIME keyword of AROPTS 146
- environment variables
  - job promotion 112
- ENVVAR, keyword of JOBREC 94, 99
- EQQMOPRL panel 113
- EQQWBGEP panel 55
- EQQWCEOD panel 64
- EQQWCGEP panel 54, 64
- EQQWDGEP panel 56
- EQQWVGEP panel 55
- EQQWWSEP panel 56
- executable job type
  - detailed syntax diagram 98

- executable jobs 17, 73
- executable or script executor 75
- executors 75
- extended agent
  - access method
    - option file 168
    - response messages 167
  - running 171
  - overview 164
- EXTENSION, keyword of JOBREC 100
- EXTRACOMMANDS, keyword of JOBREC 86

## F

- file changes, checking 102, 106
- file dependencies, defining 102
- file transfer executor 75
- file transfer job 75
- file transfer job type
  - detailed syntax diagram 84
- file transfer jobs
  - sample JSDL files 17, 73
- file transfer operations
  - sample JSDL files 17, 73
- filemonitor command 106
- files
  - JobManagerGW.ini 34, 135
- filewatch
  - filewatchdb utility 105
  - installing 102
  - maintaining log database 105
  - variable substitution 102
- filewatchdb, syntax 105

## G

- gateway
  - configure 34, 135
- generic Java job
  - template 17, 73
- generic web service call
  - template 17, 73
- global options file
  - name 169

## H

- heartbeat checking
  - z-centric agents and dynamic domain managers 42
- HTTP 41, 41
- HTTP subtasks
  - start, stop 44
- HTTPOPTS 41

## I

- IBM i jobs 73
  - AS400 jobs 73
- IBM Workload Scheduler agent
  - log configuration 22, 123
  - trace configuration 23, 125
- IBM Z Workload Scheduler Agent
  - access method
    - option file 168
  - browsing 55
- IBM Z Workload Scheduler Agents
  - defining destinations 39
  - heartbeat checking interval 39
  - SAF SSL connection with
    - z/OS
  - Z controller
    - 67
  - SSL connection with
    - z/OS
  - Z controller

- 70
- IBM Z Workload Scheduler Agents
  - on
    - SAF SSL connection with
      - Z controller
        - 67
      - SSL connection with
        - Z controller
          - 70
  - important dynamic jobs 112
  - initialization statements
    - USRREC
      - definition 45, 46
      - USRCPU keyword 46
      - USRNAM keyword 46
      - USRPSW keyword 46
  - interface 165
  - INTRACTV, keyword of JOBREC 100
  - INVOKEYTYPE, keyword of JOBREC 97

## J

- j2ee jms executor 75
- j2ee jms job 75
- J2EE jms job type
  - detailed syntax diagram 96
- J2EE job
  - configuring 138, 158
- J2EE jobs 17, 73
- JARPATH, keyword of JOBREC 93
- java executor 75
- java job 75
- Java job
  - configuring 138, 158
- Java job configuration
  - JobManager.ini file 18
- Java job type
  - detailed syntax diagram 92
- Java jobs
  - sample JSDL files 17, 73
- Java operations
  - sample JSDL files 17, 73
- Java Virtual Machine options 33, 134
- JAVAPARM, keyword of JOBREC 93
- JCL
  - RECOVER statement 142
- job definition
  - creating 73
- job environment on AS/400 120
- job environment on i5/OS 120
- job environment on IBM i 120
- job executors 62, 64
  - configuring 138, 158
  - Java options 33, 134
- job log collection
  - 152
- job log header
  - customization 150
  - template 150
- job metrics
  - collecting 174
  - SQL queries 174
- job plug-ins 62, 64
  - configuring 138, 158
  - Java options 33, 134
- job promotion
  - environment variables 112
- job promotion on dynamic pools 112
- job types
  - template 17, 73
- job types with advanced options
  - configuration files 138, 158

- configuring 138, 158
- customizing 138, 158
- Java options 33, 134
- log configuration 158
- sample JSDL files 17
- template 17
- job types with advanced options
  - configuration files
    - location 138, 158
- JOB CMD, keyword of JOBREC 100
- JOBLIB statements
  - JOBREC
    - APPENDTEXT keyword for file transfer
      - job types 86
    - AUTHALIAS keyword 96
    - CLASSNAME keyword 93
    - CONNFACTORY keyword 97, 97
    - DBNAME keyword 78, 81
    - DBTYPE keyword 78, 81
    - definition 74
    - DELETEAFTERDOWNLOAD keyword for
      - file transfer job types 86
    - DELETEAFTERUPLOAD keyword for
      - file transfer job types 86
    - ENVVAR keyword 94, 99
    - EXTENSION keyword 100
    - EXTRACOMMANDS keyword 86
    - INTRACTV keyword 100
    - INVOKEYTYPE keyword 97
    - JARPATH keyword 93
    - JAVAPARM keyword 93
    - JOB CMD keyword 100
    - JOB PWD keyword 78
    - JOB PWD keyword for file transfer
      - job types 86
    - JOB PWD keyword for J2EE jms
      - job type 97
    - JOB PWD keyword for MSSQL database
      - job type 82
    - JOB PWD keyword for script and
      - executable job type 100
    - JOB PWD keyword for web service
      - job types 91
    - JOB PWD keyword for xajob
      - job type 95
    - JOBTYP keyword 78
    - JOBTYP keyword for file transfer
      - job types 86
    - JOBTYP keyword for J2EE jms
      - job type 97
    - JOBTYP keyword for Java
      - job type 93
    - JOBTYP keyword for MSSQL database
      - job type 82
    - JOBTYP keyword for web service
      - job types 91
    - JOBTYP keyword for xajob
      - job type 95
    - JOBUSR keyword 78
    - JOBUSR keyword for file transfer
      - job types 86
    - JOBUSR keyword for J2EE jms
      - job type 97
    - JOBUSR keyword for MSSQL database
      - job type 82
    - JOBUSR keyword for script and
      - executable job type 100
    - JOBUSR keyword for web service
      - job types 91
    - JOBUSR keyword for xajob
      - job type 95
    - LOCALCODEPAGE keyword 87
    - LOCALFILE keyword 87
    - LOCALPWD keyword 87, 87
    - MAXPORT keyword 87

- MESSAGE keyword 98
- MINPORT keyword 87
- OPNAME keyword 92
- PARM keyword 92, 101
- PASSIVEMODE keyword for file transfer job types 88
- PORT keyword 79, 83
- PROTOCOL keyword 88
- REMOTE CODEPAGE keyword 88
- REMOTEFILE keyword 89
- SERVER keyword 79, 83, 89
- STATEMENT keyword 79, 83
- STDERROR keyword 101
- STDINPUT keyword 101
- STDOUTPUT keyword 101
- TIMEOUT keyword 89
- TRANSFERMODE keyword 89
- TRANSFERTYPE keyword 89
- URL keyword 92
- WRKDIR keyword 101
- JOBPWD, keyword of JOBRFC 78
- JOBPWD, keyword of JOBRFC for file transfer job types 86
- JOBPWD, keyword of JOBRFC for J2EE jms job type 97
- JOBPWD, keyword of JOBRFC for MSSQL database job type 82
- JOBPWD, keyword of JOBRFC for script and executable job type 100
- JOBPWD, keyword of JOBRFC for web service job types 91
- JOBPWD, keyword of JOBRFC for xajob job type 95
- JOBRFC 51
- JOBRFC statement of JOBLIB
  - APPENDTEXT keyword for file transfer job types 86
  - AUTHALIAS keyword 96
  - CLASSNAME keyword 93
  - CMDTYPE keyword 77, 81
  - CONNFACORY keyword 97, 97
  - DBNAME keyword 78, 81
  - DBTYPE keyword 78, 81
  - definition 74
  - DELETEAFTERDOWNLOAD keyword for file transfer job types 86
  - DELETEAFTERUPLOAD keyword for file transfer job types 86
  - ENVVAR keyword 94, 99
  - EXTENSION keyword 100
  - EXTRACOMMANDS keyword 86
  - INTRACTV keyword 100
  - INVOKEYTYPE keyword 97
  - JARPATH keyword 93
  - JAVAPARM keyword 93
  - JOBCMD keyword 100
  - JOBPWD keyword 78
  - JOBPWD keyword for file transfer job types 86
  - JOBPWD keyword for J2EE jms job type 97
  - JOBPWD keyword for MSSQL database job type 82
  - JOBPWD keyword for script and executable job type 100
  - JOBPWD keyword for web service job types 91
  - JOBPWD keyword for xajob job type 95
  - JOBTYP keyword 78
  - JOBTYP keyword for file transfer job types 86
  - JOBTYP keyword for J2EE jms job type 97

- JOBTYP keyword for Java job type 93
- JOBTYP keyword for MSSQL database job type 82
- JOBTYP keyword for web service job types 91
- JOBTYP keyword for xajob job type 95
- JOBUSR keyword 78
- JOBUSR keyword for file transfer job types 86
- JOBUSR keyword for J2EE jms job type 97
- JOBUSR keyword for MSSQL database job type 82
- JOBUSR keyword for script and executable job type 100
- JOBUSR keyword for web service job types 91
- JOBUSR keyword for xajob job type 95
- LOCALCODEPAGE keyword 87
- LOCALFILE keyword 87
- LOCALPWD keyword 87, 87
- MAXPORT keyword 87
- MESSAGE keyword 92, 98
- MINPORT keyword 87
- PARM keyword 92, 101
- PASSIVEMODE keyword for file transfer job types 88
- PORT keyword 79, 83
- PROTOCOL keyword 88
- REMOTE CODEPAGE keyword 88
- REMOTEFILE keyword 89
- SERVER keyword 79, 83, 89
- STATEMENT keyword 79, 83
- STDERROR keyword 101
- STDINPUT keyword 101
- STDOUTPUT keyword 101
- TIMEOUT keyword 89
- TRANSFERMODE keyword 89
- TRANSFERTYPE keyword 89
- URL keyword 92
- WRKDIR keyword 101
- jobs by reference
  - submitting 66
- JOBTYP, keyword of JOBRFC 78
- JOBTYP, keyword of JOBRFC for file transfer job types 86
- JOBTYP, keyword of JOBRFC for J2EE jms job type 97
- JOBTYP, keyword of JOBRFC for Java job type 93
- JOBTYP, keyword of JOBRFC for MSSQL database job type 82
- JOBTYP, keyword of JOBRFC for web service job types 91
- JOBTYP, keyword of JOBRFC for xajob job type 95
- JOBUSR, keyword of JOBRFC 78
- JOBUSR, keyword of JOBRFC for file transfer job types 86
- JOBUSR, keyword of JOBRFC for J2EE jms job type 97
- JOBUSR, keyword of JOBRFC for MSSQL database job type 82
- JOBUSR, keyword of JOBRFC for script and executable job type 100
- JOBUSR, keyword of JOBRFC for web service job types 91
- JOBUSR, keyword of JOBRFC for xajob job type 95
- JVM options 33, 134

## L

- listing destinations 39
- local options file
  - name 169
- LOCALCODEPAGE, keyword of JOBRFC 87
- LOCALFILE, keyword of JOBRFC 87
- LOCALPWD, keyword of JOBRFC 87, 87
- log configuration
  - IBM Workload Scheduler agent 22, 123
- log database, filewatch 105
- log files
  - maintenance 37
- log level on AS/400 115, 116
- log level on i5/OS 115, 116
- log level on IBM i 115, 116
- log settings on AS/400 115, 116
- log settings on i5/OS 115, 116
- log settings on IBM i 115, 116
- logging
  - job types with advanced options 158
- logs
  - agent encoding 22, 123

## M

- maintenance
  - agent configuration 37
- MAXPORT, keyword of JOBRFC 87
- MESSAGE, keyword of JOBRFC 98
- MINPORT, keyword of JOBRFC 87
- MODIFY command
  - dspdest 39
  - rfrdest 39
  - rfruser 45
- modifying
  - agent traces 25, 126
- modifying operations in the current plan panel 113
- MSSQL database job type
  - detailed syntax diagram 80
- MSSQL jobs 17, 73

## N

- name
  - global options file 169
  - local options file 169
- native job configuration
  - JobManager.ini file 18
- native job type
  - detailed syntax diagram 98
- new executors 75
  - template 17, 73
- new plug-ins 17, 73
  - template 17, 73

## O

- operating system
  - view 61
- OPNAME, keyword of JOBRFC 92
- option file
  - dynamic agent
    - access method 168
  - extended agent
    - access method 168
    - IBM Z Workload Scheduler Agent
      - access method 168
- Oracle database job type
  - detailed syntax diagram 77
- output collector
  - 152
    - activation 154
    - configuration parameters 154

- HTTP destinations
  - displaying 155
  - refreshing 155
- overview
  - access method for dynamic agent 164
  - access method for extended agent 164
  - dynamic agent 164
  - extended agent 164
- P**
  - panels
    - EQQWBGEP 55
    - EQQWCGEP 54, 64, 64
    - EQQWDGEP 56
    - EQQWMGEP 55
    - EQQWWSEP 56
  - param command 48
  - PARM, keyword of JOBREC 92, 101
  - PASSIVEMODE, keyword of JOBREC for file transfer job types 88
  - password
    - defining on agent 48
    - encrypting 72
    - job types with advanced options 48
    - managing locally on agents 48, 51
    - resolving on agent 48
  - pools
    - defining 65
  - port number
    - view 61
  - PORT, keyword of JOBREC 79, 83
  - PROTOCOL, keyword of JOBREC 88
  - proxy configuration 21
  - pulse mechanism
    - z-centric agents and dynamic domain managers 42
- R**
  - RECOVER statement 142
  - refreshing destinations 39
  - REMOECODEPAGE, keyword of JOBREC 88
  - REMOTEFIL, keyword of JOBREC 89
  - Resource advisor agent
    - JobManager.ini file 18
  - return code on AS/400 120
  - return code on i5/OS 120
  - return code on IBM i 120
  - return codes
    - NOERROR parameter 160
  - ROUTOPTS 39
  - ROUTOPTS initialization statement
    - making changes immediately effective 39
- S**
  - SAF connection SSL
    - Z controller
      - and IBM Z Workload Scheduler Agents 67
    - SAF SSL connection with IBM Z Workload Scheduler Agents 67
  - script job type
    - detailed syntax diagram 98
  - security
    - WSSTAT command 57
  - SERVER, keyword of JOBREC 79, 83, 89
  - settings
    - agent traces 25, 126

- specific job types
  - sample JSDL files 17, 73
- SQL queries for job metrics 174
  - DB2 174
  - DB2 for zOS 174
- SSL connection
  - Z controller and IBM i agents 139
  - Z controller
    - and IBM Z Workload Scheduler Agents 70
- SSL connection (SAF)
  - Z controller
    - and IBM Z Workload Scheduler Agents 67
- SSL connection with IBM i agents 139
- SSL connection with IBM Z Workload Scheduler Agents 70
- STARTTIME keyword of AROPTS 146
- STATEMENT, keyword of JOBREC 79, 83
- STDERROR, keyword of JOBREC 101
- STDINPUT, keyword of JOBREC 101
- STDOUTPUT, keyword of JOBREC 101
- syntax
  - agent
    - access method 165
  - syntax diagrams, how to read ix
  - System scanner
    - JobManager.ini file 18

- T**
  - task executors
    - configuring 138, 158
  - task options
    - access method 165
  - technical training viii
  - TIMEOUT, keyword of JOBREC 89
  - trace and log files agent
    - agent twstrace syntax 25, 127
  - trace configuration
    - IBM Workload Scheduler agent 23, 125
  - training
    - technical viii
  - TRANSFERMODE, keyword of JOBREC 89
  - TRANSFERTYPE, keyword of JOBREC 89
  - troubleshooting 157
  - TWS\_PROMOTED\_JOB 172
  - twstrace syntax
    - agent log and trace files 25, 127

- U**
  - upload job type
    - detailed syntax diagram 84
  - URL, keyword of JOBREC 92
  - user return code on AS/400 120, 121
  - user return code on i5/OS 120, 121
  - user return code on IBM i 120, 121
  - USRCPU, keyword of USRREC 46
  - USRNAM, keyword of USRREC 46
  - USRPSW, keyword of USRREC 46
  - USRREC initialization statement
    - definition 45, 46
    - making changes immediately effective 45
  - USRCPU keyword 46
  - USRNAM keyword 46
  - USRPSW keyword 46
  - utility commands
    - filemonitor 106
    - filewatch 102

- V**
  - variable
    - defining on agent 48
    - job types with advanced options 48
    - managing locally on agents 48, 51
    - resolving on agent 48
  - variable substitution 102
    - filewatch 102
    - jobs 102
  - viewing
    - agent traces 25, 126

- W**
  - web service executor 75
  - web service job 75
  - web service job type
    - detailed syntax diagram 90
  - web service jobs
    - sample JSDL files 17, 73
  - workstation status 56
  - WRKDIR, keyword of JOBREC 101
  - WSSTAT command 56

- X**
  - XA jobs 17
  - xajob executor 75
  - xajob job 75
  - xajob job type
    - detailed syntax diagram 94

- Z**
  - Z controller
    - SAF SSL connection with IBM Z Workload Scheduler Agents 67
    - SSL connection with IBM i agents 139
    - SSL connection with IBM Z Workload Scheduler Agents 70
  - z-centric workstation
    - browsing 55
    - defining 54
    - deleting 56
    - modifying definition 55
    - specifying list selection criteria 56
  - zosHttpTimeout 41